

PIPE SIZE

	4	6	8	12	16	18	20	24
BEND ANGLE	3	5	6	7	9	10	11	13
11.25°	7	9	12	15	19	21	23	26
22.5°	14	19	25	31	39	49	47	54
45°	33	45	59	74	94	104	113	131
90°								

RESTRAINED LENGTH "L" IN FEET

HORIZONTAL BEND

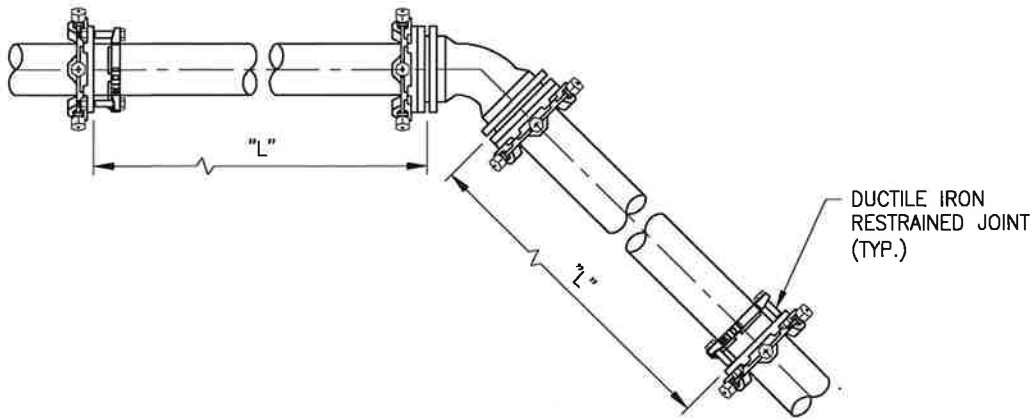

PIPE SIZE

	4	6	8	12	16	18	20	24
BEND ANGLE	10	15	19	24	30	34	37	43
11.25°	21	29	38	48	61	66	74	87
22.5°	43	61	79	100	128	142	155	181
45°								

RESTRAINED LENGTH "L" IN FEET

VERTICAL BEND

NOTES:

- IF ACTUAL CONDITIONS DIFFER FROM THOSE LISTED ABOVE OR THE REQUIRED RESTRAINED LENGTH CANNOT BE MET, THE RESTRAINED LENGTH SHALL BE DETERMINED BY THE DESIGN ENGINEER AND CONCURRED WITH THE CITY ENGINEER.
- RESTRAINTS INSTALLED PER SECTION 2-02.03 OR 2-12.

RESTRAINT OF JOINTS FOR DUCTILE IRON & PVC PIPE AT 90-DEGREE VERTICAL OR HORIZONTAL BEND

CITY OF MONTEREY PARK

PUBLIC WORKS DEPARTMENT - WATER DIVISION

STANDARD NO.

W-138

	BY	DATE
DRAWN	AM	10/02/24
REVISED	DZ	10/02/24
CHANGED	XX	XX/XX/XX

APPROVED
WATER UTILITY MANAGER

DATE 12/10/24

APPROVED
CITY ENGINEER

DATE 10/11/24

SHEET 1 OF 1