

**CITY COUNCIL OF MONTEREY PARK
THE CITY COUNCIL ACTING ON BEHALF OF THE SUCCESSOR AGENCY OF THE FORMER
REDEVELOPMENT AGENCY, THE HOUSING AUTHORITY, THE MONTEREY PARK FINANCING
AUTHORITY AND THE MONTEREY PARK GEOLOGIC HAZARD ABATEMENT DISTRICT
AGENDA**

**REGULAR CITY COUNCIL MEETING
MONTEREY PARK CITY HALL COUNCIL CHAMBERS
320 W. NEWMARK AVENUE, MONTEREY PARK, CA 91754**

**Wednesday
November 16, 2022
6:30 p.m.**

MISSION STATEMENT

The mission of the City of Monterey Park is to provide excellent services
to enhance the quality of life for our entire community.

GENERAL INFORMATION

Documents related to an Agenda item are available to the public in the City Clerk's Office located at 320 West Newmark Avenue, Monterey Park, CA 91754, during normal business hours and the City's website at <http://www.montereypark.ca.gov/AgendaCenter/City-Council-17>.

The public may watch the meeting live on the city's cable channel MPKTV (AT&T U-verse, channel 99 or Charter Communications, channel 182) or by visiting the city's website at <http://www.montereypark.ca.gov/133/City-Council-Meeting-Videos>.

PUBLIC PARTICIPATION

You may speak up to 5 minutes on Agenda item. You may combine up to 2 minutes of time with another person's speaking. No person may speak more than a total of 10 minutes. The Mayor and City Council may change the amount of time allowed for speakers. Written Communication will be accepted up to 24 hours before the meeting via email to mpclerk@montereypark.ca.gov.

Per the Americans with Disabilities Act, if you need special assistance to participate in this meeting, please call City Hall at (626) 307-1359 for reasonable accommodation at least 24 hours before a meeting. Council Chambers are wheelchair accessible.

CALL TO ORDER	Mayor
FLAG SALUTE	The Monterey Park Police Explorers
ROLL CALL	Peter Chan, Hans Liang, Henry Lo, Yvonne Yiu

AGENDA ADDITIONS, DELETIONS, CHANGES AND ADOPTIONS

PUBLIC COMMUNICATIONS:

While all comments are welcome, the Brown Act does not allow the City Council to take action on any item not on the agenda. The Council may briefly respond to comments after Public Communications is closed. Persons may, in addition to any other matter within the City Council's subject-matter jurisdiction, comment on Agenda Items at this time. If you provide public comment on a specific Agenda item at this time, however, you cannot later provide comments at the time the Agenda Item is considered.

STAFF COMMUNICATIONS:

- Police Department
- Recreation and Community Services Department
- Community Development

[1.] PRESENTATION – None.

[2.] OLD BUSINESS – None.

[3.] CONSENT CALENDAR ITEM NOS. 3A-3I

3-A. MINUTES

It is recommended that the City Council consider:

- (1) Approving the minutes from the regular meeting of October 19, 2022; the special and regular meetings of October 5, 2022 and November 5, 2022; and
- (2) Taking such additional, related, action that may be desirable.

3-B. RESOLUTION ADOPTING THE RECOGNIZED OBLIGATION PAYMENT SCHEDULE AND ADMINISTRATIVE BUDGET FOR JULY 1, 2023 – JUNE 30, 2024

It is recommended that the City Council and the City Council acting on behalf of the Successor Agency consider:

- (1) Adopting a resolution approving the Recognized Obligation Payment Schedule (ROPS 23-24 A&B) for the period between July 1, 2023 – June 30, 2024;
- (2) Approving the Successor Agency Administrative Budget for July 1, 2023 – June 30, 2024;
- (3) Directing staff to post and transmit the ROPS and Administrative Budget to the appropriate public agencies; and
- (4) Taking such additional, related, action that may be desirable.

3-C. MONTHLY INVESTMENT REPORT – OCTOBER 2022

It is recommended that the City Council consider:

- (1) Receiving and filing the monthly investment report; and
- (2) Taking such additional, related, action that may be desirable.

3-D. A RESOLUTION AMENDING THE MONTEREY PARK ADMINISTRATIVE CODE BY CHANGING “MANAGEMENT SERVICES DEPARTMENT” TO “FINANCE DEPARTMENT” AND REORGANIZING THE FINANCE DEPARTMENT

It is recommended that the City Council consider:

- (1) Adopting a Resolution amending the Monterey Park Administrative Code by Changing “Management Resources Department” to “Finance Department” and reorganizing the Finance Department; and
- (2) Taking such additional, related, action that may be desirable.

Environmental Review:

The proposed action is exempt from review under the California Environmental Quality Act (California Public Resources Code §§ 21000, *et seq.*, “CEQA”) and CEQA regulations (14 California Code of Regulations (“CCR”) §§ 15000, *et seq.*) because it establishes rules and procedures to clarify existing policies and practices related to government organization; does not involve any commitment to a specific project which could result in a potentially significant physical impact on the environment; and constitutes an organizational or administrative activity that will not result in direct or indirect physical changes in the environment. Accordingly, the action does not constitute a “project” that requires environmental review (see specifically 14 CCR § 15378(b)(4-5)).

3-E. SCHEDULE A PUBLIC HEARING FOR CONSIDERATION OF A RESOLUTION OF THE CITY COUNCIL OF THE CITY OF MONTEREY PARK, CALIFORNIA CONFIRMING THE 2022 ANNUAL REPORT AND THE LEVY OF ASSESSMENTS FOR DOWNTOWN BUSINESS IMPROVEMENT DISTRICT NO. 1 FOR PROGRAM YEAR 2023

It is recommended that the City Council consider:

- (1) Receiving and filing the 2022 BID Annual Report with the City Clerk.
- (2) Adopting the Resolution of Intent and set the Public Hearing for December 7, 2022, for consideration of the 2023 BID assessments and
- (3) Taking such additional, related, action that may be desirable.

3-F. TITLE VI – CIVIL RIGHTS PROGRAM UPDATE FOR SPIRIT BUS

It is recommended that the City Council consider:

- (1) Approving the Title VI of the Civil Rights Act of 1964 (Title VI) Program Update;
- (2) Authorizing the City Manager or designee to submit the Title VI Program Update to the Los Angeles County Metro Office of Civil Rights and Federal Transit Administration (FTA); and
- (3) Taking such additional, related, action that may be desirable.

3-G. APPROVAL OF SECOND AMENDMENT TO AGREEMENT WITH MARIPOSA LANDSCAPES, INC.

It is recommended that the City Council consider:

- (1) Authorizing the City Manager to execute the Second Amendment, in a form approved by the City Attorney, that would increase the budget of the Landscape Maintenance Agreement with Mariposa Landscapes, Inc., from \$118,000 annually to an amount not to exceed \$170,000 annually. Additionally, the term of the Agreement would be extended to June 30, 2025, with an option for an additional two-year extension;
- (2) Taking such additional, related, action that may be desirable.

3-H. 2022 RESIDENTIAL STREET REHABILITATION – AWARD OF PUBLIC WORKS CONTRACT TO ALL AMERICAN ASPHALT

It is recommended that the City Council consider:

- (1) Adopting amended resolution No. 2022-R38 updating the project list for FY 22-23 SB1 rehabilitation project by adding Polk Way to the list of locations;
- (2) Authorizing the City Manager to execute a public works contract, in a form approved by the City Attorney, with All American Asphalt of Corona, CA in the contract amount of \$869,422 for the 2022 Residential Street Rehabilitation Project;
- (3) Authorizing the Director of Public Works to approve change orders and contingency up to \$86,943, or 10% of the contract amount; and,
- (4) Taking such additional, related, action that may be desirable.

CEQA (California Environmental Quality Act):

Since the proposed work is a minor alteration to an existing public facility, this project is Class 1 Categorically Exempt pursuant to the California Environmental Quality Act (CEQA).

3-I. TASK ORDERS TO PUBLIC WORKS ON-CALL AGREEMENT WITH TRANSTECH ENGINEERS FOR STAFF AUGMENTATION AND PLAN CHECK SERVICES

It is recommended that the City Council consider:

- (1) Authorizing the City Manager to execute Task Order 1 per Transtech Engineers On-call Agreement No. 2282-A, in a form approved by the City Attorney, for staff augmentation in the Public Works department, not to exceed \$600,000 annually;
- (2) Authorizing the City Manager to execute Task Order 2 per Transtech Engineers On-call Agreement No. 2282-A, in a form approved by the City Attorney, for staff augmentation in the Community Development department, not to exceed \$210,000 annually;
- (3) Authorizing the City Manager to execute Task Order 3 per Transtech Engineers On-call Agreement No. 2282-A, in a form approved by the City Attorney, for Plan Check Services, not to exceed \$692,000 annually;
- (4) Appropriating \$237,000 from the General Fund to cover costs for Task Order 3 – Plan Check Services; and
- (5) Taking such additional, related, action that may be desirable.

[4.] PUBLIC HEARING

4-A. CONSIDERATION AND POSSIBLE ACTION TO CONDUCT A PUBLIC HEARING TO WAIVE FURTHER READING AND ADOPT AN ORDINANCE AMENDING TITLES 16 AND 17 OF THE MONTEREY PARK MUNICIPAL CODE BY ADOPTING THE 2022 EDITION OF THE CALIFORNIA BUILDING STANDARDS CODE AND THE MONTEREY PARK AMENDMENTS TO THE CALIFORNIA BUILDING STANDARDS CODE

It is recommended that the City Council consider:

- (1) Opening a public hearing and take testimonial and documentary evidence;
- (2) After considering the evidence, waiving the second reading. and adopting the proposed Ordinance; and
- (3) Taking such additional, related, action that may be desirable.

4-B. PUBLIC HEARING AND CONSIDERATION OF ADOPTING A RESOLUTION AMENDING THE 2021-2029 HOUSING ELEMENT (GPA 22-02) TO THE MONTEREY PARK GENERAL PLAN EFFECTIVE JANUARY 19, 2022

It is recommended that the City Council consider:

- (1) Opening the public hearing to receive testimonial and documentary evidence;
- (2) After closing the public hearing and considering the evidence, adopt a Resolution amending the Monterey Park Housing Element effective January 19, 2022;
- (3) Authorize the City Manager, or designee, to prepare and transmit the final documents to the California Department of Housing and Community Development ("HCD"); and
- (4) Taking such additional, related, action that may be desirable.

CEQA (California Environmental Quality Act):

The draft Resolution amends the City's Housing Element ("HE") that was adopted January 19, 2022. There are no significant, substantive, amendments to the HE that would result from adopting the Resolution. Consequently, the findings and conclusions of Resolution No. 2022-R2 are incorporated into the draft Resolution; no additional environmental findings are required.

4-C. A PUBLIC HEARING TO CONSIDER AN APPLICATION FOR A WIRELESS TELECOMMUNICATIONS FACILITY PERMIT (DRB-22-49) TO ALLOW A NEW WIRELESS TELECOMMUNICATIONS FACILITY ON AN EXISTING SOUTHERN CALIFORNIA EDISON TRANSMISSION TOWER (DISH WIRELESS)

It is recommended that the City Council consider:

- (1) Opening a public hearing and taking testimonial and documentary evidence;
- (2) After closing the public hearing and considering the evidence submitted during that public hearing, adopt the proposed Resolution granting a Wireless Telecommunications Facility Permit (DRB-22-49) with conditions of approval; and
- (3) Taking such additional, related, action that may be desirable.

CEQA (California Environmental Quality Act):

The proposed action is exempt from additional environmental review under the California Environmental Quality Act (California Public Resources Code §§ 21000, *et seq.*, "CEQA") and CEQA Guidelines (14 California Code of Regulations ("CCR") §§ 15000, *et seq.*) because it consists of construction and location of a one new small facility or structure. Consequently, the project constitutes a Class 3 categorical exemption. A Notice of Exemption has been prepared accordingly.

[5.] NEW BUSINESS

5-A. INTRODUCING AND WAIVING THE FIRST READING OF AN ORDINANCE EXTENDING THE EFFECTIVE DATE FOR THE 2020 MONTEREY PARK BUSINESS RECOVERY PROGRAM FROM DECEMBER 30, 2022 TO MAY 31, 2023.

It is recommended that the City Council consider:

- (1) Introducing and waiving the first reading of an ordinance extending the effective date for the 2020 Monterey Park Business Recovery Program from December 30, 2022 to May 31, 2023.
- (2) Taking such additional, related, action that may be desirable.

[6.] CITY COMMUNICATIONS (CITY COUNCIL)

6-A. A RESOLUTION OF THE CITY COUNCIL OF THE CITY OF MONTEREY PARK RECOGNIZING NOVEMBER 13 – 19, 2022, AS LA VS. HATE UNITED AGAINST HATE WEEK (REQUESTED BY MAYOR LO)

It is recommended that the City Council consider:

- (1) Adopting a resolution of the City Council of the City of Monterey Park recognizing November 13 – 19, 2022, as LA Vs. Hate United Against Hate week
- (2) Taking such additional, related, action that may be desirable.

[7.] FUTURE AGENDA ITEMS

[8.] CLOSED SESSION (IF REQUIRED; CITY ATTORNEY TO ANNOUNCE)

ADJOURN



City Council Staff Report

DATE: November 16, 2022

AGENDA ITEM NO: Consent Calendar - 3A

TO: The Honorable Mayor and City Council
FROM: Vincent D. Chang, City Clerk
SUBJECT: Minutes

RECOMMENDATION:

It is recommended that the City Council consider:

1. Approving the minutes from the regular meeting of October 19, 2022; the special and regular meetings of October 5, 2022 and November 2, 2022; and
2. Taking such additional, related, action that may be desirable.

EXECUTIVE SUMMARY:

None.

BACKGROUND:

None.

FISCAL IMPACT:

None.

Respectfully submitted,

Prepared by:

Handwritten signature of Vincent D. Chang in blue ink.

Vincent D. Chang
City Clerk

Handwritten signature of Christine Sakata in blue ink.

Christine Sakata
Senior Clerk Typist

Approved By:

Handwritten signature of Ron Bow in blue ink.

Ron Bow
City Manager

ATTACHMENT(S):

1. Draft Minutes

ATTACHMENT 1

Draft Minutes

**MINUTES
MONTEREY PARK CITY COUNCIL
FINANCING AUTHORITY (MPFA)
HOUSING AUTHORITY (MPHA)
GEOLOGIC HAZARD ABATEMENT DISTRICT (GHAD)
SUCCESSOR AGENCY (SA)
SPECIAL MEETING
OCTOBER 5, 2022**

The City Council, the Financing Authority (MPFA), the Housing Authority (MPHA), the Geologic Hazard Abatement District (GHAD), and the Successor Agency (SA) of the City of Monterey Park held a Special Meeting of the Council in Room 266, Second Floor of City Hall located at 320 West Newmark Avenue in the City of Monterey Park on Wednesday, October 5, 2022 at 5:00 p.m.

CALL TO ORDER:

Mayor Lo called the meeting to order at 5:00 p.m.

ROLL CALL:

Deputy City Clerk Cindy Trang called the roll:

Council Members Present: Peter Chan, Hans Liang, Henry Lo, Yvonne Yiu

Council Members Absent: None

ALSO PRESENT: City Manager Ron Bow, City Attorney Karl Berger, Assistant City Manager Inez Alvarez, Director of Management Services Martha Garcia, Economic Development Manager Joseph Torres, Deputy City Clerk Cindy Trang

PUBLIC COMMUNICATIONS

- Wing Young expressed his concern on street takeovers and proposed to have roundabouts. He also suggested that there should be traffic control and would like to join a committee, if one is available.
- Deputy City Clerk Trang received, filed, and read into the record written communications from Linda Tang on Agenda Item No. 2B, SteelCraft Development Project. She requested the city determine whether or not the city-owned site falls under the Surplus Land Act; and to consider if the development can be turned into affordable housing.

1-A. PRESENTATION REGARDING CITY COUNCIL CONSIDERATION OF ADMINISTRATIVE SPACE AND PROPERTY NEEDS

Action Taken: The City Council received and filed a presentation provided by the City Manager regarding the City's existing administrative office and department space needs and potential for property lease, acquisition or expansion.

MISSION STATEMENT

The mission of the City of Monterey Park is to provide excellent services to enhance the quality of life for our entire community

1-B. APPOINTMENT OF REAL PROPERTY NEGOTIATORS

Action Taken: The City Council appointed the City Manager, Assistant City Manager, Management Services Director, and City Attorney as the real property negotiators for Closed Session Item No. 2-A.

Motion: Moved by Council Member Liang and seconded by Council Member Chan, motion carried by the following vote:

Ayes: Council Members: Yiu, Chan, Liang, Lo
Noes: Council Members: None
Absent: Council Members: None
Abstain: Council Members: None

2. CLOSED SESSION

The City Council adjourned to Closed Session at 5:10 p.m.

2-A. CONFERENCE WITH REAL PROPERTY NEGOTIATORS – GOVERNMENT CODE § 54957.6: three items

Property: 900 Corporate Center Drive, AIN 5237-022-017; 601 Potrero Grande Drive, AIN 5265-025-058; and 2100 Saturn Street, AIN 5265-026-055

City Negotiators: Ron Bow, City Manager
Karl H. Berger, City Attorney
Inez Alvarez, Assistant City Manager
Martha Garcia, Management Services Director

Negotiating Party: 900 Corporate Center Drive – Omninet LACC, LLC ET AL
601 Potrero Grande Drive – BHE 601 Potrero Grande LLC/BH Properties, LLC
2100 Saturn Street – BHE 601 Potrero Grande LLC/BH Properties, LLC

Under negotiation: Lease terms, purchase price, and terms of payment

2-B. CONFERENCE WITH REAL PROPERTY NEGOTIATORS ON RECOMMENDATIONS REGARDING THE STEELCRAFT COUNTER PROPOSAL TERMS

Property: 109 N. Lincoln Avenue, AIN 5255-008-901 / 5255-008-902900

City Negotiators: Ron Bow, City Manager
Karl H. Berger, City Attorney
Inez Alvarez, Assistant City Manager
Martha Garcia, Management Services Director
Joseph Torres, Economic Development Manager

Negotiating Party: SteelCraft Long Beach, LP c/o Martin Howard

Under negotiation: Potential to lease/sell City-owned property, terms, and price

2-C. CONFERENCE WITH LABOR NEGOTIATORS, PURSUANT TO CALIFORNIA GOVERNMENT CODE SECTION § 54957.6

City Negotiators: Steve Berliner, Esq. from Liebert Cassidy & Whitmore (the City's special counsel for labor matters) and Christine Tomikawa, Director of Human Resources and Risk Management

Employee Organizations: Confidential Employees' Association, Firefighters' Association, Mid-Management Association, Police Captains' Association, Police Officers' Association, Police Officers' Mid-Management Association, Professional Chief Officers' Association, and Service Employees International Union, Local 721

RECONVENE & ADJOURNMENT

The City Council reconvened from Closed Session with all Council Members present. The meeting was adjourned at 6:24 p.m.

Action Taken: No reportable action taken.

Vincent D. Chang
City Clerk

MINUTES
MONTEREY PARK CITY COUNCIL
FINANCING AUTHORITY (MPFA)
HOUSING AUTHORITY (MPHA)
GEOLOGIC HAZARD ABATEMENT DISTRICT (GHAD)
SUCCESSOR AGENCY (SA)
REGULAR MEETING
OCTOBER 5, 2022

The City Council, the Financing Authority (MPFA), the Housing Authority (MPHA), the Geologic Hazard Abatement District (GHAD), and the Successor Agency (SA) of the City of Monterey Park held a Regular Meeting of the Council in the Council Chamber, located at 320 West Newmark Avenue in the City of Monterey Park, Wednesday, October 5, 2022 at 6:30 p.m.

CALL TO ORDER:

Mayor Lo called the meeting to order at 6:32 p.m.

FLAG SALUTE:

Mayor Lo.

ROLL CALL:

City Clerk Vincent Chang called the roll:

Council Members Present: Peter Chan, Hans Liang, Henry Lo, Yvonne Yiu
 Council Members Absent: None.

ALSO PRESENT: City Attorney Karl Berger, City Manager Ron Bow, Assistant City Manager Inez Alvarez, Fire Chief Matt Hallock, City Librarian Diana Garcia, Director of Recreation & Community Services Robert Aguirre, Director of Human Resources & Risk Management Christine Tomikawa, Director of Management Services Martha Garcia, Director of Public Works Shawn Igoe, Interim Police Chief Scott Wiese, Fire Department Battalion Chief Chris Thompson, Battalion Chief Mark Khail, Planning Manager Jessica Serrano, Deputy City Clerk Cindy Trang, Adult Literacy Coordinator Victor Castellanos, Community Communications Coordinator Randy Ishino

VIRTUALLY PRESENT Economic Development Manager Joseph Torres

AGENDA ADDITIONS, DELETIONS, CHANGES AND ADOPTIONS

None

PUBLIC COMMUNICATIONS

- Sarkis Antonian spoke about the stop signs on Alhambra and Graves Avenues. He suggests having flashing red stop signs.

MISSION STATEMENT

The mission of the City of Monterey Park is to provide excellent services to enhance the quality of life for our entire community

- Joseph Leon reported his meeting with financial consultant, Michael Bush, on possible new investments and financial management options.
- Maychelle Yee voiced her objection on item 4A.
- Delario Robinson expressed that his focus is on finance, and that services we need in Monterey Park requires money. He spoke on Measure MP and why we need it.

STAFF COMMUNICATIONS

- City Clerk's Office: City Clerk Chang provided a PowerPoint presentation regarding the upcoming election and the location of the Vote Centers and permanent ballot boxes.
- Fire Department: Fire Department Battalion Chief Thompson invited the residents to the earthquake event – America's Great Shakeout on October 20, 2022.
- Library Services: City Librarian Garcia presented a PowerPoint for their upcoming foundation fundraiser and literacy program. Adult Literacy Coordinator Castellanos invited members of the community to become a tutor for English and Job Skill workshops.
- Department of Public Works: City Manager Bow introduced the new Public Work's Director, Shawn Igoe.
- Recreation and Community Service Department: Director of Recreation and Community Services Aguirre informed the community of all their upcoming events for the month of October.

1. PRESENTATION

Matters listed under presentation are informational content and for discussion only.

1A. UNITED STATES 247TH BIRTHDAY CELEBRATION

Commander Philip S. Ujie thanked Mayor Lo for hosting the United States Navy's 247th Birthday celebration. Navy Commander Arthur Fong helped with the traditional cutting of the cake.

RECESSED AND RECONVENED

The City Council recessed at 7:25 p.m. and reconvened at 7:36 p.m.

2. OLD BUSINESS - None.

3. CONSENT CALENDAR ITEMS NOS. 3A-3G

Matters listed under consent calendar are considered to be routine, ongoing business and are enacted by one motion unless specified.

Action Taken: Council Member Yiu reported a potential conflict of interest as her spouse's employment is in the healthcare industry, therefore she did not participate on Item No. 3C. City Council approved and adopted Item Nos. 3B, 3C, 3D, 3F, and 3G on Consent Calendar, excluding Item Nos. 3A and 3E which were pulled for discussion and separate motion, reading resolutions and ordinances by the title only and waiving further reading thereof.

Motion: Moved by Council Member Chan and seconded by Council Member Yiu, motion carried by the following vote:

Ayes: Council Members: Chan, Liang, Lo
Noes: Council Members: None
Absent: Council Members: None (Yiu, Item No. 3C)
Abstain: Council Members: None

3A. MONTHLY INVESTMENT REPORT – AUGUST 2022

As of August 31, 2022 invested funds for the City of Monterey Park is \$88,697,579.10.

Public Communication:

- City Treasurer Leon gave an update on the August 2022 monthly investment report and the City's investment policy. He stated that the next month's report will be his last before he is termed out of office.

Action Taken: The City Council received and filed the monthly investment report of August 2022.

3B. MINUTES

Approving the minutes from the special meeting of August 1, 2022 at 6:30 p.m.

Action Taken: The City Council approved the minutes from the special meeting of August 1, 2022 at 6:30 p.m. on Consent Calendar.

3C. BALLOT MEASURE FOR HEALTHCARE WORKER MINIMUM WAGE PETITION

On August 1, 2022, the City Council voted 2-1 to adopt Ordinance No. 2223 which added the Healthcare Worker Minimum Wage initiative petition (certified by

Resolution No. 2022-R62) to the Monterey Park Municipal Code. A lawsuit captioned *Gonzalez v. City of Monterey Park* LASC Case No. 22STCP02942 was filed by opponents to the Healthcare Worker Minimum Wage initiative which challenged the City Council's action regarding Ordinance No. 2223. After a closed session held on August 17, 2022 regarding the lawsuit, the City Council directed the City Attorney not to defend that lawsuit (see attached meeting minutes, to the staff report). Consequently, on September 2, 2022, the Honorable Mary H. Strobel issued the attached (to the staff report) stipulated judgment in the case (the "Writ").

Action Taken: Council Member Yiu declared a potential Conflict of Interest as her spouse's employment is in the healthcare industry, therefore she did not participate on this item. The City Council received and filed this report; and adopted Resolution 2022-R76 upon a 3-0 vote, adding an initiative to the ballot for the regular municipal election to be held November 5, 2024 on Consent Calendar.

Resolution No. 2022-R76:

A RESOLUTION ADDING AN INITIATIVE MEASURE TO THE BALLOT FOR NOVEMBER 5, 2024 REGULAR MUNICIPAL ELECTION PURSUANT TO ELECTIONS CODE §§ 1405 AND 9215(B) IN ACCORDANCE WITH THE PEREMPTORY WRITE OF MANDATE ISSUED ON SEPTEMBER 2, 2022

3D. CONSIDERATION AND POSSIBLE ACTION TO ADOPT THE 2022 CONFLICT OF INTEREST CODE FOR THE CITY OF MONTEREY PARK IN ACCORDANCE WITH THE POLITICAL REFORM ACT

Pursuant to the Political Reform Act, Government Code § 81000, *et seq.*, every local agency is required to review its Conflict of Interest Code disclosure biennially to determine if the Code is accurate or in need of amendment. City staff has reviewed its previous determinations relating to disclosure levels and determined that Resolution No. 12198 should be amended to include revisions consistent with existing positions in the City.

Action Taken: The City Council adopted Resolution No. 2022-R77 amending the City's Conflict of Interest Code on Consent Calendar.

Resolution No. 2022-R77:

A RESOLUTION ADOPTING THE 2022 CONFLICT OF INTEREST CODE FOR THE CITY OF MONTEREY PARK IN ACCORDANCE WITH THE POLITICAL REFORM ACT

3E. A RESOLUTION DECLARING THE MONTH OF OCTOBER AS BREAST CANCER AWARENESS MONTH

National Breast Cancer Awareness Month takes place every year during the month of October. It is an annual health campaign organized by major breast cancer awareness charities to increase the awareness

Resolution No. 2022-R62) to the Monterey Park Municipal Code. A lawsuit captioned *Gonzalez v. City of Monterey Park* LASC Case No. 22STCP02942 was filed by opponents to the Healthcare Worker Minimum Wage initiative which challenged the City Council's action regarding Ordinance No. 2223. After a closed session held on August 17, 2022 regarding the lawsuit, the City Council directed the City Attorney not to defend that lawsuit (see attached meeting minutes, to the staff report). Consequently, on September 2, 2022, the Honorable Mary H. Strobel issued the attached (to the staff report) stipulated judgment in the case (the "Writ").

Action Taken: Council Member Yiu declared a potential Conflict of Interest as her spouse's employment is in the healthcare industry, therefore she did not participate on this item. The City Council received and filed this report; and adopted Resolution 2022-R76 upon a 3-0 vote, adding an initiative to the ballot for the regular municipal election to be held November 5, 2024 on Consent Calendar.

Resolution No. 2022-R76:

A RESOLUTION ADDING AN INITIATIVE MEASURE TO THE BALLOT FOR NOVEMBER 5, 2024 REGULAR MUNICIPAL ELECTION PURSUANT TO ELECTIONS CODE §§ 1405 AND 9215(B) IN ACCORDANCE WITH THE PEREMPTORY WRITE OF MANDATE ISSUED ON SEPTEMBER 2, 2022

3D. CONSIDERATION AND POSSIBLE ACTION TO ADOPT THE 2022 CONFLICT OF INTEREST CODE FOR THE CITY OF MONTEREY PARK IN ACCORDANCE WITH THE POLITICAL REFORM ACT

Pursuant to the Political Reform Act, Government Code § 81000, *et seq.*, every local agency is required to review its Conflict of Interest Code disclosure biennially to determine if the Code is accurate or in need of amendment. City staff has reviewed its previous determinations relating to disclosure levels and determined that Resolution No. 12198 should be amended to include revisions consistent with existing positions in the City.

Action Taken: The City Council adopted Resolution No. 2022-R77 amending the City's Conflict of Interest Code on Consent Calendar.

Resolution No. 2022-R77:

A RESOLUTION ADOPTING THE 2022 CONFLICT OF INTEREST CODE FOR THE CITY OF MONTEREY PARK IN ACCORDANCE WITH THE POLITICAL REFORM ACT

3E. A RESOLUTION DECLARING THE MONTH OF OCTOBER AS BREAST CANCER AWARENESS MONTH

National Breast Cancer Awareness Month takes place every year during the month of October. It is an annual health campaign organized by major breast cancer awareness charities to increase the awareness

of the disease and to raise funds for research into its cause, prevention, diagnosis, treatment, and cure.

Action Taken: The City Council adopted Resolution No. 2022-R78 declaring the month of October as Breast Cancer Awareness Month.

Motion: Moved by Council Member Liang and seconded by Council Member Chan, motion carried by the following vote:

Ayes: Council Members: Yiu, Chan, Liang, Lo
Noes: Council Members: None
Absent: Council Members: None
Abstain: Council Members: None

Resolution No. 2022-R78:

A RESOLUTION OF THE CITY COUNCIL OF THE CITY OF MONTEREY PARK, CALIFORNIA DECLARING OCTOBER 2022 AS BREAST CANCER AWARENESS MONTH IN MONTEREY PARK

3F. CALIFORNIA GOVERNOR'S OFFICE OF EMERGENCY SERVICES – HAZARD MITIGATION GRANT PROGRAM UPDATE

On May 25, 2022, The California Governor's Office of Emergency Services (Cal OES) awarded the City of Monterey Park, Fire Department, grant funds to update the City's Local Hazard Mitigation Plan (LHMP). Per the Scope of Work, the grant will fund the procurement of a consultant to provide project management and subject matter expertise throughout the planning process. Additionally, to ensure an inclusive and comprehensive plan, translation services and public outreach supplies will be utilized to reach a broader audience. The culminating result is a FEMA approved multi-hazard mitigation plan.

On August 1, 2022, staff advertised a Request for Proposal (RFP) on the City's website, to solicit bids for a consultant. In addition to posting the RFP, staff also emailed prospective agencies, notifying them of the RFP and inviting them to bid. The RFP closed on September 1, 2022. Staff received a total of two bids. One from the Resiliency Initiative and the second from Emergency Planning Consultants. While both applicants proved to have significant qualifications, staff identified Emergency Planning Consultants as the more knowledgeable agency, due to its extensive experience working with local municipalities.

Emergency Planning Consultants successfully completed over 120 Federal Emergency Management Agency (FEMA) approved LHMP projects. Moreover, the agency most notably collaborated with the City of Rosemead, City of South El Monte, and the City of Montebello on their FEMA approved LHMPs. This prior working experience may allow for the agency to provide further insight to potential hazards that extend beyond Monterey Park's boundaries. It also gives the agency some

understanding and working knowledge of the demographics and communities the City serves.

Moreover, the agency clearly outlined a fast-track timeline, to guarantee the project completed in a timely fashion, without skipping steps or missing pertinent deadlines. The agency's assurance of a thorough and timely completion of the project will allow staff to adhere to Cal OES' grant deadlines. Emergency Planning Consultant is requesting a total of \$45,000 to complete the project.

Action Taken: The City Council received and filed the report on Consent Calendar.

3G. RESOLUTION RATIFYING THE CITY'S APPLICATION SUBMITTAL AND AUTHORIZING THE CITY MANAGER, OR DESIGNEE, TO RECEIVED, AND APPROPRIATE GRANT FUNDS FROM THE DEPARTMENT OF TRANSPORTATION GRANTS

On September 7, 2022, City Council adopted a Local Road Safety Plan (LRSP) and a Vision Zero Policy for the City of Monterey Park. The LRSP is intended to proactively address local traffic safety needs, reduce traffic accident fatalities and serious injuries on all public roads. The Vision Zero Policy calls for the development of an Action Plan that prioritizes safe roadways and the highest level of safety for all road users through new policies, systems, and infrastructure improvements for pedestrians, bicyclists, and motorists. As part of the City's commitment to these traffic safety strategies, staff submitted grant applications to the Department of Transportation Highway Safety Improvement Program (HSIP) grant and the Safe Streets and Roads for All (SS4A) Discretionary Grant. Staff requests City Council adopt a Resolution to ratify the submission of the City's applications for these two grant programs and authorize the City Manager or Designee to Receive, and Appropriate Grant Funds, if awarded.

Action Taken: The City Council adopted Resolution No. 2022-R79 ratifying the City's application submittal and authorized the City Manager, or designee, to receive and appropriate grant funds from the Department of Transportation Highway Safety Improvement Program and the Safe Streets and Roads for All Discretionary Grant Program on Consent Calendar.

Resolution No. 2022-R79:

RESOLUTION RATIFYING THE CITY'S APPLICATION SUBMISSION AND AUTHORIZING THE CITY MANAGER, OR DESIGNEE, TO RECEIVE, AND APPROPRIATE GRANT FUNDS FROM THE DEPARTMENT OF TRANSPORTATION GRANT PROGRAMS FOR WHICH THE CITY IS ELIGIBLE

4. PUBLIC HEARING

4A. CONSIDERATION AND POSSIBLE ACTION TO ADOPT A RESOLUTION FINDING A PUBLIC NECESSITY TO ACQUIRE REAL PROPERTY THROUGH EMINENT DOMAIN AND AUTHORIZING THE CITY ATTORNEY, OR DESIGNEE, TO FILE EMINENT DOMAIN PROCEEDINGS TO ACQUIRE REAL PROPERTY OWNED BY CENTER INT'L INVESTMENTS ("CII") IDENTIFIED BY ASSESSOR PARCEL NO. 5254-002-031, LOCATED ON GARVEY AVENUE FOR THE PURPOSES OF COMPLETING AND MAINTAINING THE GOODVIEWS ABATEMENT PROJECT ("GAP")

On August 22, 2022, the City sent a fair market purchase offer to the owners of Assessor Parcel No. 5254-002-031 (the "property") for the purpose of of completing and maintain the Goodviews Abatement Project ("GAP"), which is located at 1688 West Garvey Avenue. A copy of the Offer Letter is attached as Exhibit 1 of the Staff Report. The property owner did not respond to the City's repeated offers for acquiring the Property. Since the parties cannot agree on price and terms for the sale of the Property, the City Manager and City Attorney recommend that the City Council consider adopting the attached Resolution to the staff report finding a public necessity to acquire the Property through eminent domain. (See attached Exhibit 2 of the staff report.)

CEQA (California Environmental Quality Act):

The findings set fort in Resolution No. 12553 (adopted June 16, 2021) and Section 2 of Resolution No. 12255 (adopted June 16, 2021), are incorporated by reference. For ease of reference, Resolution No. 12553 certifies the Final Environmental Impact Report for 1688 West Garvey Avenue Project (State Clearinghouse No. 2020070419); Resolution No. 12255 authorizes the GAP to protect public health and safety without the need for additional environmental review (see, *Ca/Beach Advocates v. City of Solana Beach* (2002) 103 Cal.App.4th 529: CEQA findings regarding an anticipated imminent emergency are valid).

Public Communications:

- Karrie On, representative of Center International Investment Incorporation (CII,) spoke on behalf of CII and communicated the plans CII and the City had with the project. She asked the council to reject the proposal and thoroughly investigate the city's work.
- James Bradshaw, resident of Monterey Park, asked what the intended public use of the property would be for eminent domain. He voiced his opinion on the condition of his slope due to the hillside stabilization work done by the city. He mentioned his family history and involvement with the city.
- Teresa Real Sebastian expressed her concern regarding the funding source for this project and inquired as to that public use for this property.

- Cindy Yee urged that the item should be postponed until the newly elected council takes office.
- Jason Dhing articulated his thoughts on the funding for this project.
- Benjamin Venti stated that the property for this project was a prehistoric landslide and should not have anything built on this lot.
- City Clerk Chang received and filed three written communications. (1) Sean P. O'Connor, Sheppard, Mullin, Richter & Hampton LLP, objecting to the Adoption of Necessity for the Acquisition of Certain Real Property; (2) Sean P. O'Connor, Sheppard, Mullin, Richter & Hampton LLP on behalf of Karrie On, Director of CII, who completed the Request to be Heard on Resolution of Necessity for the Acquisition of Certain Real Property form; (3) Alan A. Sozio, Burke, Williams, & Sorensen, LLP, submitted a letter in response to the Objection to Adoption of Resolution of Necessity file by CII.

Action Taken: The City Council opened the public hearing at 7:59 p.m. to receive and file this report; closed the public hearing at 9:16 p.m.; After considering the report and any other relevant evidence from the entire administrative record, adopted Resolution No. 2022-R80, authorized the City attorney, or designee, to commence an eminent domain action for acquiring real property located at Assessor Parcel No. 5254-002-031 (requires an affirmative TWO-THIRDS (2/3) vote of the City Council).

Motion: Moved by Council Member Liang and seconded by Council Member Chan, motion carried by the following vote:

Ayes: Council Members: Yiu, Chan, Liang, Lo
Noes: Council Members: None
Absent: Council Members: None
Abstain: Council Members: None

Resolution No. 2022-R80:

A RESOLUTION FINDING AND DETERMINING THAT THE PUBLIC INTEREST, CONVENIENCE AND NECESSITY REQUIRE THE ACQUISITION OF CERTAIN PROPERTY FOR PUBLIC PURPOSES RELATED TO THE GOODVIEWS ABATEMENT PROJECT ("GAP")

5. **NEW BUSINESS** – None.

6. CITY COMMUNICATIONS (CITY COUNCIL)

Council Member Yiu attended the Fall Education Summit in Lake Arrowhead last week. She described her experience from the one-day event on Emergency Operation Centers.

Council Member Chan reported his attendance on the League of California City's Conference and Asian Pacific Islanders (API) Elected Officials Summit.

Council Member Liang attended the Monterey Park Police Department's Youth Service Golf Tournament to say farewell to former Police Chief Kelly Gordon. He also commended the Police Department regarding the chase pursuit that took place in Monterey Park.

Mayor Lo talked about his attendance to Asian Youth Center (AYC) 33rd Gala dinner to recognize unsung heroes and recognized Monterey Park resident Daisy Ma.

7. FUTURE AGENDA ITEMS

8. CLOSED SESSION (IF REQUIRED; CITY ATTORNEY TO ANNOUNCE)

None.

ADJOURNMENT

There being no further business for consideration, the meeting was adjourned at 9:26 p.m.

Vincent D. Chang
City Clerk

MINUTES
MONTEREY PARK CITY COUNCIL
FINANCING AUTHORITY (MPFA)
HOUSING AUTHORITY (MPHA)
GEOLOGIC HAZARD ABATEMENT DISTRICT (GHAD)
SUCCESSOR AGENCY (SA)
REGULAR MEETING
OCTOBER 19, 2022

The City Council, the Financing Authority (MPFA), the Housing Authority (MPHA), the Geologic Hazard Abatement District (GHAD), and the Successor Agency (SA) of the City of Monterey Park held a Regular Meeting of the Council in the Council Chamber, located at 320 West Newmark Avenue in the City of Monterey Park, Wednesday, October 19, 2022 at 6:30 p.m.

CALL TO ORDER:

Mayor Lo called the meeting to order at 6:30 p.m.

FLAG SALUTE:

The Monterey Park Police Explorers

ROLL CALL:

City Clerk Vincent Chang called the roll:

Council Members Present: Peter Chan, Henry Lo, Yvonne Yiu

Council Members Absent: Hans Liang

ALSO PRESENT: City Treasurer Joseph Leon, City Manager Ron Bow, City Attorney Karl Berger, Assistant City Manager Inez Alvarez, Fire Chief Matt Hallock, City Librarian Diana Garcia, Director of Human Resources & Risk Management Christine Tomikawa, Director of Management Services Martha Garcia, Director of Public Works Shawn Igoe, Interim Police Chief Scott Wiese, Planning Manager Jessica Serrano, Deputy City Clerk Cindy Trang, Recreation Supervisor Memo Chavez, Senior Librarian Deborah Takahashi

VIRTUALLY PRESENT Director of Recreation & Community Services Robert Aguirre, Economic Development Manager Joseph Torres

AGENDA ADDITIONS, DELETIONS, CHANGES AND ADOPTIONS

City Manager Bow announced a correction to Item No. 3E, he requested the City Council consider adding the recommendation “adopting a resolution authorizing the City Manager, or designee, to apply for, receive, and appropriate grant funds for the State Homeland Security Program for grant year 2021;”. The resolution was attached to the staff report.

MISSION STATEMENT

The mission of the City of Monterey Park is to provide excellent services to enhance the quality of life for our entire community

PUBLIC COMMUNICATIONS

- Sarkis Antonian recommended having a task force for car theft parts.
- Nancy Arcuri thanked the City Council on explaining the eminent domain process and the actions taken with Center International Investment.
- Joseph Leon reported out from the San Gabriel Valley Mosquito Abatement District meeting that there are no reports of the West Nile Virus in Monterey Park. He provided the contact information to the District 626-814-9466 should the public have additional questions or concerns.
- Leilani Morales gave her speaking time to speaker Amy Lee.
- Amy Lee shared her concern on the issues that was brought up from the last City Council meeting on October 5, 2022, on Agenda Item No. 4A - Goodviews Abatement Project (GAP) Eminent Domain. She expressed her concern about the cost for the project and that there was not enough transparency with the project.
- Teresa Real Sebastian thanked Amy Lee on her statement regarding the Goodviews Abatement Project (GAP), Eminent Domain. She provided her viewpoint regarding the city's capital improvements project and how those funds are to maintain city facilities.
- Maychelle Yee commented on the information provided by speakers Teresa Real Sebastian and Amy Lee regarding the GAP project.
- Candace Griego, Principal of Brightwood Elementary School, presented the Monterey Park Fire Department with a plaque for their collaboration with Brightwood School celebrating student achievements.

STAFF COMMUNICATIONS

- City Clerk's Office: City Clerk Chang provided a PowerPoint presentation with information on the city's November 8, 2022 election.
- Department of Public Works: Director of Public Works Igoe reminded the community that the last outreach for the Spirit Bus survey will take place at the City's Monster Mash Event on October 20th. The survey deadline is October 31, 2022.
- Recreation and Community Service Department: Recreation Supervisor Chavez and Senior Librarian Takahashi invited the community to the city's Monster Mash event at Barnes Park on October 20, 2022 and the Community Health Fair at Langley Center on October 22, 2022.

1. **PRESENTATION** - None

Matters listed under presentation are informational content and for discussion only.

2. **OLD BUSINESS** - None.

3. **CONSENT CALENDAR ITEMS NOS. 3A-3J**

Matters listed under consent calendar are considered to be routine, ongoing business and are enacted by one motion unless specified.

Action Taken: The City Council approved and adopted Item Nos. 3A, 3B, 3D, 3E as amended, 3G, 3H, and 3I on Consent Calendar, excluding Item Nos. 3C, 3F, and 3J which were pulled for discussion and separate motion, reading resolutions and ordinances by the title only and waiving further reading thereof.

Motion: Moved by Council Member Chan and seconded by Council Member Yiu, motion carried by the following vote:

Ayes: Council Members: Yiu, Chan, Lo
Noes: Council Members: None
Absent: Council Members: Liang
Abstain: Council Members: None

3A. MONTHLY INVESTMENT REPORT – SEPTEMBER 2022

As of September 30, 2022 invested funds for the City of Monterey Park is \$81,731,613.91.

Action Taken: The City Council received and filed the monthly investment report of September 2022.

3B. MINUTES

Approving the minutes from the special and regular meetings of September 7, 2022.

Action Taken: The City Council approved the minutes from the special and regular meetings of September 7, 2022 on Consent Calendar.

3C. REPORT SUBMITTED TO THE CITY COUNCIL PURSUANT TO GOVERNMENT CODE 8630 REGARDING THE CITY'S EMPLOYMENT EMERGENCY (PER RESOLUTION NOS. 2022-R49 AND 2022-R67); CONTINUANCE OF SUCH EMERGENCY

From the last report on August 17, 2022, the City is in the recruitment process to fill Fire Marshal, Code Enforcement Officers, Recreation Manager, Water Utility Manager, Senior Water Production System Operator, and Public Works Inspector. The City filled a Senior Accountant, two full-time Maintenance Worker, two full-time Communication Dispatcher, and various part-time vacancies for School Crossing Guard, Recreation Leader and Librarian.

With the employment emergency order, the City provided internal opportunities to parttime employees for full-time employment and current full-time employees are applying or vacancies in different City departments. The City is recruiting for 46 vacant full-time positions. Staff recommends extending the employment emergency as there are still critical vacancies in the Water Treatment and Water Distribution divisions.

Public Speakers:

- Teresa Real Sebastian requested an elaboration on the context of the Emergency Order and inquired on how long the employment emergency will be extended.

Action Taken: The City Council received and filed this report and extended the Employment Emergency.

Motion: Moved by Council Member Chan and seconded by Council Member Yiu, motion carried by the following vote:

Ayes: Council Members: Yiu, Chan, Lo
Noes: Council Members: None
Absent: Council Members: Liang
Abstain: Council Members: None

3D. 2020 URBAN AREA SECURITY INITIATIVE (UASI) GRANT PROGRAM UPDATE

The Urban Area Security Initiative (UASI) Grant Program is a Homeland Security Grant designed to enhance regional preparedness and capabilities in designated high-threat, high-populated areas. Currently, the Fire Department (Department) is participating in the 2020 UASI Grant Program cycle. The Department was awarded \$1 15,000 for the purchase of Urban Search & Rescue (USAR) equipment. Staff identified two specialized pieces of equipment, a CTC Strut rescue kit and a Maxiforce G2 US&R Lift Bag kit for procurement.

In accordance with the City's Purchasing & Contracting Policy 20-01 and with MPMC Chapters 3.20 and 3.90, staff solicited quotes from the following companies: LN Curtis, NAFECO, Municipal Emergency Services, Trans-Care Rescue, and Feld Fire. Due to the unique specifications of the equipment, vendors must be authorized by the manufacturers, Paratech Emergency Equipment Manufacturers and Rescue42, to sell these products. LN Curtis & Sons, is the authorized vendor (for the State of California) to sell the CTC Strut rescue kit and the Maxiforce G2 US&R Lift Bag kit. The total purchase for both items from LN Curtis & Sons is \$65,232.54.

The performance period for the grant ends in May of 2023. Subgrantees must complete and submit, for review, all purchasing paperwork by January of 2023. Due to time constraints with the acquisition process and to adhere to the grant purchasing deadline, under Section 9 of the Budget Resolution No. 2002-R46 (adopted June 15, 2022), staff procured the equipment. The alternative was to forfeit the funds and return \$65,232.54 to the Los Angeles Mayor's Office for redistribution to another grantee.

Action Taken: The City Council received and filed this report on Consent Calendar.

3E. STATE HOMELAND SECURITY PROGRAM SUBRECIPIENT AGREEMENT GRANT YEAR 2021 - AWARD OF AGREEMENT

The County of Los Angeles is a Subgrantee of the State Homeland Security Program Grant Year 2021 that is provided by the U.S. Department of Homeland Security. Per the subrecipient agreement, the County of Los Angeles is authorized to enter into a subrecipient agreement with the City of Monterey Park, which includes a distribution of SHSP 2021 grant funds to the City of Monterey Park in the amount of \$342,500. A portion of the award is dedicated to fund a Regional Training (RTG) Intelligence Chief position, in the amount of \$230,000. The remaining amount \$112,500 is earmarked for Urban Search and Rescue (USAR) equipment. Staff recommends City Council to authorize the City to execute an agreement, in a form approved by the City Attorney, with the County of Los Angeles for an amount not to exceed \$342,500 for the SHSP 2021 Grant.

Action Taken: The City Council authorized the City Manager to execute an agreement, in a form approved by the City Attorney, with the County of Los Angeles for an amount not to exceed \$342,500 for the State Homeland Security Program Grant Year 2021 (SHSP 2021); appropriate grant funds for SHSP 2021 as amended to add the additional recommendation adopting Resolution No. 2022-R81 authorizing the City Manager, or designee, to apply for, receive, and appropriate grant funds for the State Homeland Security Program for grant year 2021 on Consent Calendar.

Resolution No. 2022-R81:

A RESOLUTION AUTHORIZING THE CITY MANAGER, OR DESIGNEE, TO APPLY FOR, RECEIVE, AND APPROPRIATE GRANT FUNDS FOR THE STATE HOMELAND SECURITY PROGRAM FOR GRANT YEAR 2021

3F. RESOLUTION DECLARING THE MONTH OF NOVEMBER AS “MOVEMBER” TO RAISE AWARENESS TO PROSTATE AND OTHER MALE CANCERS

The Movember Foundation is the leading global organization committed to changing the face of men's health. The Movember community has raised \$911 million to date and funded over 1,250 programs in 20 countries (<https://us.movember.com/>). This work is saving and improving the lives of men affected by prostate cancer, testicular cancer and mental health programs.

The Foundation challenges men to grow mustaches during Movember (formerly known as November), to spark conversation and raise vital funds for its men's health programs. To date, over 5 million mustaches have been grown worldwide.

The mustaches are a symbol to promote awareness regarding men's health issues and to encourage yearly checkups regarding prostate and testicular cancer. The growth of a new mustache prompts a conversation, which in turn generates awareness and educates people on the health issues men face.

The Vision of the Movember Foundation is to have an everlasting impact of the face of men's health.

Action Taken: The City Council adopted Resolution No. 2022-R82 declaring the month of November as “Movember”.

Motion: Moved by Council Member Chan and seconded by Council Member Yiu, motion carried by the following vote:

Ayes: Council Members: Yiu, Chan, Lo
Noes: Council Members: None
Absent: Council Members: Liang
Abstain: Council Members: None

Resolution No. 2022-R82:

A RESOLUTION OF THE CITY COUNCIL OF THE CITY OF MONTEREY PARK DECLARING THE MONTH OF NOVEMBER AS “MOVEMBER”, AN ANNUAL EVENT INVOLVING MEN GROWING MUSTACHES DURING THE MONTH TO RAISE AWARENESS OF PROSTATE CANCER AND OTHER MALE CANCER AND ASSOCIATED CHARITIES

3G. CALIFORNIA LIBRARY LITERACY SERVICES (CLLS) ENGLISH AS A SECOND LANGUAGE (ESL) GRANT FISCAL YEAR 2022-2023

The LAMP Literacy Program was notified of a \$34,976 award from the California Library Literacy Services (CLLS). The LAMP Literacy Program will utilize the grant to continue to assist adult learners achieve their literacy goals, improve job prospects and become United States citizens.

Action Taken: The City Council accepted grant funds from California Library Literacy Services in the amount of \$34,796.00 for English as a Second Language services at the library; and authorized the City's Management Services Department to allocate \$34,796.00 in grant funding to the Fiscal Year 2022-2023 budget on Consent Calendar.

3H. GRANULAR ACTIVATED CARBON REPLACEMENT – AWARD OF CONTRACT

Staff released a solicitation for bids seeking Granular Activated Carbon (GAC) replacement for the Well 1, 3, 10, Fern Treatment Plant on August 24, 2022. Staff received four bids and is requesting award of three-year maintenance contracts to both Calgon Carbon Corp. and Aqueous Vets, LLC for a combined total not-to-exceed \$304,500 annually.

CEQA (California Environmental Quality Act)

The proposed work involves minor alterations to existing public facilities and therefore is Class 1 Categorically Exempt pursuant to the California Environmental Quality Act (CEQA).

Action Taken: The City Council authorized the City Manager to execute three-year maintenance agreements, in a form approved by the City Attorney, with Calgon Carbon Corporation and Aqueous Vets, LLC, for a combined total not to exceed \$304,500 annually for Granular Activated Carbon (GAC) Replacement for the Well 1, 3, 10, Fern Treatment Plant on Consent Calendar.

3I. WELL AND BOOSTER PUMP MAINTENANCE – AWARD OF CONTRACT

On August 24, 2022, the Water Division released a bid for Well and Booster Pump Maintenance Services. Staff is requesting award of a three-year maintenance, on-call contract, in a form approved by the City Attorney, with General Pump Company for an amount not to exceed \$400,000 annually.

CEQA (California Environmental Quality Act)

The proposed work involves minor alterations to existing public facilities and therefore is Class 1 Categorically Exempt pursuant to the California Environmental Quality Act (CEQA).

Action Taken: The City Council authorized the City Manager to execute three-year maintenance agreements, in a form approved by the City Attorney, with General Pump Company in an amount not to exceed \$400,000 annually for Well and Booster Pump Preventative Maintenance Services on Consent Calendar.

3J. METRO ACTIVE TRANSPORT MAT CYCLE 1 PROGRAM – POTRERO GRANDE

In April 2020, the City of Monterey Park submitted a joint grant application on behalf of the City of Montebello, City of Rosemead, and LA County Department of Public Works for the Los Angeles County Metropolitan Transportation Authority (LACMTA) Metro ActiveTransport (MAT) Cycle 1 Program. The proposed project included various improvements along the Riggin, Potrero Grande Corridor for an estimated \$6.4 M. LACMTA selected the project for award and has provided a Funding Agreement for “1st-Riggin-Potrero Grande Corridor, LCMFTA Project #C1103.” Staff recommends City Council authorize the City Manager to execute the Agreement, in the amount of \$6,366,225 and to proceed with the project. An overview of the project was previously presented to City Council at the January 19, 2022 meeting.

Public Speakers:

- Arman Sebastian gave his speaking time to speaker Teresa Real Sebastian.
- Teresa Real Sebastian asked if the community received any notice regarding this project in the neighborhood. She suggested that the city provide notifications to residence of projects that will be affecting their streets. She also questioned one of the proposed routes under the SR-60 west-bound offramp.

Discussion:

- Director of Public works Igoe presented a PowerPoint on the MAT Cycle 1 Grant
 - Potrero Grande Improvements program.

Action Taken: The City Council authorized the City Manager to execute a Funding Agreement, in a form approved by the City Attorney, with the Los Angeles County Metropolitan Transportation Authority for the Metro Active Transport Cycle 1 Program, for 1st-Riggin-Potrero Grande Corridor Improvements, in the amount of \$6,366,225; and authorized the City Manager to appropriate project funds for the Mat Cycle 1: 1st-Riggin-Potrero Grande Corridor Improvements per the Funding Agreement budget.

Motion: Moved by Council Member Chan and seconded by Council Member Yiu, motion carried by the following vote:

Ayes: Council Members: Yiu, Chan, Lo
Noes: Council Members: None
Absent: Council Members: Liang
Abstain: Council Members: None

4. **PUBLIC HEARING**

4A. **CONTINUATION OF PUBLIC HEARING REGARDING CONSIDERATION OF A RESOLUTION OF THE CITY COUNCIL OF THE CITY OF MONTEREY PARK, CALIFORNIA FOR SUBMITTAL AND RECEIPT OF GRANT FUNDS FOR THE PERMANENT LOCAL HOUSING ALLOCATION PROGRAM THROUGH THE STATE DEPARTMENT OF HOUSING AND COMMUNITY DEVELOPMENT**

A public notice was published on October 6, 2022, in the Monterey Park Progress newspaper to inform the public of the 10-day public review period Public Hearing for discussions on the 2019-2023 PLHA Plan. The draft PLHA Plan has been placed for public review on the City's website under the Management Services Department – Housing. City staff has not received any written comments concerning PLHA Plan. At this time, additional time is needed to revise the Housing Element Annual Performance Report for each corresponding application funding years and is requesting that the item be continued to November 2, 2022.

Action Taken: The City Council continued the public hearing for October 19, 2022 to November 2, 2022.

Motion: Moved by Council Member Chan and seconded by Council Member Yiu, motion carried by the following vote:

Ayes: Council Members: Yiu, Chan, Lo
Noes: Council Members: None
Absent: Council Members: Liang
Abstain: Council Members: None

5. **NEW BUSINESS** – None.

6. **CITY COMMUNICATIONS (CITY COUNCIL)**

Council Member Yiu referred to the previous City Council meeting and appreciates all the comments and perspective regarding the Goodviews Abatement Project. She also defined what eminent domain is.

Council Member Chan attended the State of the City Address conducted by Mayor Lo in the City Hall Council Chambers on October 12, 2022. He also attended the United States Navy's 247th birthday in San Pedro.

Mayor Lo thanked everyone that came to the State of the City's Address. He also attended the flag raising ceremony at East Los Angeles College for "National Coming Out Day" on Tuesday, October 11, 2022 and commended the college for partnering with Monterey Park and providing a space for students to learn and be nurtured.

7. **FUTURE AGENDA ITEMS** – None.
8. **CLOSED SESSION (IF REQUIRED; CITY ATTORNEY TO ANNOUNCE)**
None.

ADJOURNMENT

There being no further business for consideration, the meeting was adjourned at 7:48 p.m.

Vincent D. Chang
City Clerk

MINUTES
MONTEREY PARK CITY COUNCIL
FINANCING AUTHORITY (MPFA)
HOUSING AUTHORITY (MPHA)
GEOLOGIC HAZARD ABATEMENT DISTRICT (GHAD)
SUCCESSOR AGENCY (SA)
SPECIAL MEETING
NOVEMBER 2, 2022

The City Council, the Financing Authority (MPFA), the Housing Authority (MPHA), the Geologic Hazard Abatement District (GHAD), and the Successor Agency (SA) of the City of Monterey Park held a Special Meeting of the Council in Room 266, Second Floor of City Hall located at 320 West Newmark Avenue in the City of Monterey Park on Wednesday, November 2, 2022 at 5:30 p.m.

CALL TO ORDER:

Mayor Lo called the meeting to order at 5:30 p.m.

ROLL CALL:

City Mayor Lo called the roll:

Council Members Present: Peter Chan, Hans Liang, Henry Lo, Yvonne Yiu

Council Members Absent: None

ALSO PRESENT: City Manager Ron Bow, City Attorney Karl Berger, Director of Management Services Martha Garcia, Director Human Resources and Risk Management Christine Tomikawa

VIRTUALLY PRESENT: Steve Berliner of Liebert Cassidy & Whitmore

ORAL AND WRITTEN COMMUNICATIONS – None.

1. CLOSED SESSION

The City Council adjourned to Closed Session at 5:30 p.m.

1-A. CONFERENCE WITH LABOR NEGOTIATORS, PURSUANT TO CALIFORNIA GOVERNMENT CODE § 54957.6

City Negotiators: Steve Berliner, Esq. from Liebert Cassidy & Whitmore (the City's special counsel for labor matters) and Christine Tomikawa, Director of Human Resources and Risk Management

MISSION STATEMENT

The mission of the City of Monterey Park is to provide excellent services to enhance the quality of life for our entire community

Employee Organizations: Confidential Employees' Association, Firefighters' Association, Mid-Management Association, Police Captains' Association, Police Officers' Association, Police Officers' Mid-Management Association, Professional Chief Officers' Association, and Service Employees International Union, Local 721

RECONVENE & ADJOURNMENT

The City Council reconvened from Closed Session with all Council Members present. The meeting was adjourned at 6:04 p.m.

Action Taken: No reportable action taken.

Vincent D. Chang
City Clerk

MINUTES
MONTEREY PARK CITY COUNCIL
FINANCING AUTHORITY (MPFA)
HOUSING AUTHORITY (MPHA)
GEOLOGIC HAZARD ABATEMENT DISTRICT (GHAD)
SUCCESSOR AGENCY (SA)
REGULAR MEETING
NOVEMBER 2, 2022

The City Council, the Financing Authority (MPFA), the Housing Authority (MPHA), the Geologic Hazard Abatement District (GHAD), and the Successor Agency (SA) of the City of Monterey Park held a Regular Meeting of the Council in the Council Chamber, located at 320 West Newmark Avenue in the City of Monterey Park, Wednesday, November 2, 2022 at 6:30 p.m.

CALL TO ORDER:

Mayor Lo called the meeting to order at 6:30 p.m.

FLAG SALUTE:

City Manager Bow led the flag salute.

ROLL CALL:

City Clerk Vincent Chang called the roll:

Council Members Present: Peter Chan, Hans Liang, Henry Lo, Yvonne Yiu
 Council Members Absent: None.

ALSO PRESENT: City Attorney Karl Berger, City Manager Ron Bow, Fire Chief Matt Hallock, City Librarian Diana Garcia, Director of Human Resources & Risk Management Christine Tomikawa, Director of Management Services Martha Garcia, Director of Public Works Shawn Igoe, Interim Police Chief Scott Wiese, Police Lieutenant Paul Yniguez, Police Lieutenant Gustavo Jimenez, Police Lieutenant Bob Hung, Police Lieutenant Brenda Iglesias, Police Office Delon Lam, Officer Tony Nguyen, Officer Izzy Flores, Economic Development Manager Joseph Torres, Planning Manager Jessica Serrano, Public Works Manager Chris Reyes, Acting Building Official Dennis Tarango, Recreation Supervisor Orlando Muro, Assistant Deputy City Clerk Helena Cho, Community Communications Coordinator Randy Ishino

VIRTUALLY PRESENT: Assistant City Manager Inez Alvarez, Director of Recreation & Community Services Robert Aguirre, Housing Consultant Debbie Sottek

AGENDA ADDITIONS, DELETIONS, CHANGES AND ADOPTIONS

City Manager Bow requested an additional staff communication from Economic Development to be heard after Recreation and Community Services Department.

MISSION STATEMENT

The mission of the City of Monterey Park is to provide excellent services to enhance the quality of life for our entire community

PUBLIC COMMUNICATIONS

- Nancy Acuri thanked Council Members Liang and Chan, City Clerk Chang and City Treasurer Leon for their service as elected official.
- Vinh Ngo also thanked the outgoing elected officials for their service.

STAFF COMMUNICATIONS

- City Clerk's Office: City Clerk Chang provided a PowerPoint presentation regarding the November 8, 2022 election.
- Fire Department: Fire Chief Hallock presented a short video on safety for deep frying a turkey for Thanksgiving.
- Library Services: City Librarian Garcia presented a PowerPoint on upcoming programs for the library including In-N-Out Burger reading program, Preschool Fair, Kanopy streaming program, brainfuse HelpNow tutoring services, Dungeon and Dragon video game program, in addition to other services and programs.
- Police Department: Interim Police Chief Wiese introduced the City's Police Department N.E.T. Team and presented a PowerPoint presentation on the 2022 POALAC Centurion Awards N.E.T. Team.
- Recreation and Community Service Department: Recreation Supervisor Muro thanked the participated and sponsors of the Health Fair event and invited the community to the upcoming events.

1. PRESENTATION – None.

Matters listed under presentation are informational content and for discussion only.

2. OLD BUSINESS – None.

3. CONSENT CALENDAR ITEMS NOS. 3A-3F

Matters listed under consent calendar are considered to be routine, ongoing business and are enacted by one motion unless specified.

Action Taken: City Council approved and adopted Item Nos. 3A, 3B, 3C, 3D, 3E and 3F on Consent Calendar, reading resolutions and ordinances by the title only and waiving further reading thereof.

Motion: Moved by Council Member Chan and seconded by Council Member Liang, motion carried by the following vote:

Ayes: Council Members: Yiu, Chan, Liang, Lo
Noes: Council Members: None
Absent: Council Members: None
Abstain: Council Members: None

3A. CONSIDERATION AND POSSIBLE ACTION TO ADOPT A RESOLUTION TO RECORD A NOTICE OF NUISANCE ABATEMENT LIEN AGAINST CERTAIN PROPERTY IN THE CITY (APN 5254-002-031)

Adopting the resolution attached to the staff report which will allow the City to recover costs, including attorney's fees, incurred the City's abatement of the public nuisance present on certain real property located in the City (APN 5254-002-031) (the "Property") owned by Center Int'l Investments, Inc. ("CII"). The Resolution authorizes recording the associated Notice of Nuisance Abatement Lien in the amount of \$2,665,405.63. This will be the third lien on the Property for the time period of July 1, 2022 and September 30, 2022. After recording this lien, the liens against the Property will total \$8,355.236.17.

CEQA (California Environmental Quality Act):

Adoption of this Resolution is exempt from the California Environmental Quality Act ("CEQA") under CEQA Guidelines § 15061(b)(3) because it can be seen with certainty that there is no possibility that the action proposed by the proposed resolution would have a significant effect on the environment.

Action Taken: The City Council adopted Resolution No. 2022-R83 to record a Notice of Nuisance Abatement Lien on Consent Calendar.

Resolution No. 2022-R83:

A RESOLUTION AUTHORIZING THE RECORDATION OF A NUISANCE ABATEMENT LIEN AGAINST CERTAIN REAL PROPERTY LOCATED IN THE CITY (APN 5254-002-031)

3B. RESOLUTION APPROVING THE MEMORANDUM OF UNDERSTANDING BETWEEN THE CITY AND THE MONTEREY PARK FIREFIGHTERS' ASSOCIATION FOR THE TERM OF JULY 1, 2022 TO JUNE 30, 2023

Representatives of the City of Monterey Park ("City") and MPFFA met and conferred to negotiate the terms and conditions of a new Memorandum of Understanding ("MOU") regarding employment. The parties reached an agreement on an MOU effective July 1, 2022 to June 30, 2023.

Action Taken: The City Council adopted Resolution No. 2022-84 approving a Memorandum of Understanding (“MOU”) between the City of Monterey Park and the Monterey Park Firefighters’ Association (“MPFFA”). The MPFFA represents the Firefighters, Fire Engineers, and Fire Captains in the Monterey Park Fire Department; and authorized budget appropriation of approximately \$337,134 from the General Fund and \$270,000 from the American Rescue Plan Act (ARPA) Funds for the 2022-2023 fiscal year on Consent Calendar.

Resolution No. 2022-R84:

A RESOLUTION APPROVING THE MEMORANDUM OF UNDERSTANDING FOR CONTRACT YEAR 2022-2023 BETWEEN THE CITY OF MONTEREY PARK AND THE MONTEREY PARK FIREFIGHTERS’ ASSOCIATION

3C. CONSIDERATION OF MAP. NO. 82847 FOR A SINGLE LOT SUBDIVISION (CONDOMINIUM PURPOSES) TO FACILITATE AN TWO-UNIT RESIDENTIAL DEVELOPMENT, LOCATED AT 601 W EMERSON AVE

The proposed Parcel Map was reviewed by the Public Works Director for compliance with applicable law. Except for the required public improvements, it meets all legal requirements. Because the Parcel Map is offering a real property dedication, the Parcel Map must be approved by the City Council per Monterey Park Municipal Code § 20.08.090.

CEQA (California Environmental Quality Act):

The Project was categorically exempt from the requirements of CEQA pursuant to CEQA Guidelines § 15315 and 15332 as a Class 15 categorical exemption (Minor Land Divisions) and Class 32 categorical exemption (Infill Development).

Action Taken: The City Council (1) adopted Resolution No. 2022-R85 approving Parcel Map No. 82847; (2) accepted a 15-foot corner radius property line dedication at the northwest intersection of West Emerson Avenue and North Moore Avenue for street and public utility purposes; and (3) authorized the Public Works Director, or designee, to sign Parcel Map No. 82847 on Consent Calendar.

Resolution No. 2022-R85:

A RESOLUTION APPROVING FINAL PARCEL MAP NO. 82847 FOR A TWO-UNIT RESIDENTIAL CONDOMINIUM PROJECT AT 601 W EMERSON AVE

3D. HVAC IMPROVEMENTS AT VARIOUS CITY FACILITIES – AWARD OF PUBLIC WORKS CONTRACT TO CARRIER CORPORATION

Per Resolution No. 2022-R32, the Public Works Director solicited bids for the HVAC Improvements at Various City Facilities (HVAC Project), Capital Improvement Project No. 96029. The public bid opening for the HVAC Project was held on October 13, 2022.

Two bids were received: Carrier Corporation and F.M. Thomas Air Conditioning, Inc. Staff recommends that the City Council authorize the City Manager to execute a Public Works contract with Carrier Corporation for the HVAC Project in the amount of \$329,001.00, plus 5% contingency.

CEQA (California Environmental Quality Act):

Since the proposed work is a minor alteration to an existing public facility, this project is Class 1 Categorically Exempt pursuant to the California Environmental Quality Act (CEQA).

Action Taken: The City Council (1) authorized the City Manager to execute a public works contract, in a form approved by the City Attorney, with Carrier Corporation of Industry, CA in the contract amount of \$329,001 for the HVAC Improvements at Various City Facilities project; (2) authorized the Director of Public Works to approve change orders and contingency up to \$16,450, or 5% of the contract amount; and (3) appropriated an additional \$95,451 from the American Rescue Plan Act Fund for this project on Consent Calendar.

3E. MODIFICATION TO AGREEMENT NO. 2077-A WITH MOBILE SOURCE AIR POLLUTION REVIEW COMMITTEE (MSRC) AND PURCHASE OF A CNG ASPHALT TRUCK

The City has a current agreement with the Mobile Source Air Pollution Review Committee (MSRC) for the purchase of CNG bus as part of its 2017 Local Government Partnership Program. Staff recommends City Council approve the repurposing of grant funds to purchase a CNG Asphalt Truck under the MSRC program. If approved, the City would submit a request to the MSRC to modify the project's scope of work and request an extension to complete the purchase of the vehicle and other grant requirements.

Action Taken: The City Council (1) authorized the City Manager or designee to submit a request for modification to Agreement No. 2077-A with Mobile Source Air Pollution Review Committee (MSRC) for the purchase of a CNG Asphalt Truck; (2) authorized the purchase of a CNG Asphalt Truck from PC Loader, through Sourcewell Contract No. 052417-PBL; and (3) appropriated \$327,405 from the AQMD 2766 Subvention Fund (247) for the purchase of this vehicle on Consent Calendar.

3F. PROFESSIONAL SERVICE AGREEMENT WITH AKM CONSULTING ENGINEERS FOR ON-CALL ENGINEERING SERVICES

Staff recommends executing an on-call professional services agreement with AKM Consulting Engineers (AKM) for on-call water and sewer engineering services. AKM is an experienced firm with expertise in planning, design, and construction management of water, recycled water, and wastewater projects.

Through its work on the City's Water Master Plan update, AKM has become a subject matter expert on the City's water system and infrastructure, making them the most qualified firm to meet the City's current needs. Individual task orders assigned to AKM will not exceed \$60,000, however, multiple task orders may be issued

Action Taken: The City Council authorized the City Manager to execute a 3-year professional service agreement with AKM Consulting Engineers, to provide On-Call Engineering Services, in a form approved by the City Attorney on Consent Calendar.

4. PUBLIC HEARING

4A. A PUBLIC HEARING TO CONSIDER INTRODUCTION AND FIRST READING OF AN ORDINANCE (ZONING CODE NO. 22-01) ADDING CHAPTER 21.19 (INCLUSIONARY HOUSING) TO TITLE 21 (ZONING) OF THE MONTEREY PARK MUNICIPAL CODE TO IMPLEMENT THE MONTEREY PARK HOUSING ELEMENT; AND ADOPTION OF A RESOLUTION ESTABLISHING AN IN-LIEU INCLUSIONARY HOUSING FEE CALCULATION

The Monterey Park Housing Element provides that the City Council will consider an inclusionary housing ordinance before the end of 2022. A draft Ordinance and Resolution establishing an in-lieu inclusionary housing fee calculation was prepared for City Council consideration.

The Ordinance (Attachment 1 to the staff report) would encourage the production of affordable units in new housing developments. This is accomplished by several methods, or a combination of methods: (1) require actual construction of affordable units; (2) payment of an in-lieu fee to the City that commensurate with the cost of a the "affordability gap" between the market and affordable rate for the new unit or the construction of off-site affordable units within the City; and/or (3) construction of affordable units at an off-site location within the City.

The Resolution (Attachment 2 to the staff report), establishes an in-lieu inclusionary housing fee calculation. This would equate to the financial impact or "affordability gap" that is created by the Ordinance's inclusionary housing requirements. In-lieu fees would be deposited into an affordable housing trust fund. Separate from the City's General Fund, the affordable housing trust fund monies must be used exclusively for encouraging affordable housing in the City.

CEQA (California Environmental Quality Act):

Pursuant to the California Environmental Quality Act (Public Resources Code §§ 21000, *et seq.*; "CEQA") and its implementing guidelines (California Code of Regulations, Title 14, Division 6, Chapter 3, the "CEQA Guidelines"), the proposed Ordinance and Resolution (ZCA 22-01) are exempt from further CEQA review for the following reasons: (1) they will not result in a direct or reasonably foreseeable indirect physical change in the environment (CEQA Guidelines § 15060(c)(2)); (2) there is no possibility that the Ordinance or Resolution may have a significant effect

on the environment because any potential, future, housing projects would undergo separate environmental review (CEQA Guidelines § 15061(b)(3)); and (3) the Ordinance and Resolution, by themselves, do not constitute a “project” as defined in the CEQA Guidelines because they involve a policy action that is legislative implementing affordable housing policy and affects prospective future housing development to comply with Housing Element Program 15 (CEQA Guidelines § 15378). The notice of exemption prepared for this project is contained in Attachment 4 to the staff report.

RECOMMENDATION:

It is recommended that the City Council consider:

1. Opening a public hearing and taking testimonial and documentary evidence;
2. After closing the public hearing and considering the evidence submitted during that public hearing:
 - a. Introduce and waive first reading of Ordinance No. _____ adding Chapter 21.19 (Inclusionary Housing) to Monterey Park Municipal Code Title 21 (Zoning) to implement the Monterey Park Housing Element
 - b. Adopt Resolution No. _____ establishing an in-lieu inclusionary housing fee calculation; and
3. Taking such additional, related, action that may be desirable.

Public Speakers:

- City Clerk Chang received and filed one written communication from Linda Tang who articulated her support for the development and implementation of an inclusionary housing ordinance. She provided her recommendations on changes to the draft ordinance.

Discussion:

- Planning Manager Serrano presented a PowerPoint Presentation for this Agenda Item.

Action Taken: The City Council opened the public hearing at 7:07 p.m. to take testimonial and documentary evidence, closed the public hearing at 7:10 p.m.; The City Council ensued in discussion and provided feedback to staff on changes they would like to see. (1) more information on density bonuses (2) further define the definition of “project” in the draft ordinance to provide a graduated scaled based system of units and percentages of affordable housing (3) provide more information on how the moneys from the trust funds will be utilized. City Attorney Berger suggested adding a sentence at the end of section 21.19.050 subsection A3 of the ordinance “such additional uses may be designated by written resolution” By consensus, the City Council requested that staff bring this item back for further consideration incorporating comments made by the City Council.

4B. PUBLIC HEARING AND ADOPTION OF A RESOLUTION AUTHORIZING THE APPLICATION AND RECEIPT OF GRANT FUNDS FOR THE PERMANENT LOCAL HOUSING ALLOCATION PROGRAM THROUGH THE CALIFORNIA DEPARTMENT OF HOUSING AND COMMUNITY DEVELOPMENT

On August 17, 2022, the California Department of Housing and Community Development (HCD) issued a Notice of Funding Availability (NOFA) for Permanent Local Housing Allocation Program Entitlement funds. This NOFA provides the City with an opportunity to apply for \$1,359,916 in 2019, 2020 and 2021 Permanent Local Housing Allocation (PLHA) Program funds. The PLHA Program provides a permanent source of funding to cities and counties to help meet the unmet need for affordable housing and increase the supply of affordable housing units.

Action Taken: The City Council (1) opened the continued public hearing at 8:16 p.m. to receive testimonial and documentary evidence; (2) after closing the public hearing at 8:17 p.m. with no registered speakers, considered the evidence, adopted Resolution No. 2022-R86 authorizing the City Manager, or designee, to apply for and accept grant funding in the amount of \$1,913,226 from the California Department of Housing and Community Development's Permanent Local Housing Allocation Program; (3) authorized the City Manager, of designee, to prepare and transmit the final documents to the California Department of Housing and Community Development ("HCD"); (4) authorized the City Manager, or designee to execute and submit the Standard Agreement for this grant, including amendments, in a form approved by the City Attorney; (5) authorized the City Manager, or designee to take all actions necessary or desirable implement the proposed Permanent Local Housing Allocation Program five-year plan; (6) and authorized City Manager, or designee to appropriate \$814,496 to the FY22-23 budget.

Resolution No. 2022-R86:

A RESOLUTION AUTHORIZING THE CITY MANAGER, OR DESIGNEE, TO APPLY FOR, RECEIVE AND APPROVE GRANT FUNDS FOR THE PERMANENT LOCAL HOUSING ALLOCATION PROGRAM

Motion: Moved by Council Member Liang and seconded by Council Member Yiu, motion carried by the following vote:

Ayes:	Council Members:	Yiu, Chan, Lo, Liang
Noes:	Council Members:	None
Absent:	Council Members:	None
Abstain:	Council Members:	None

5. NEW BUSINESS

5A. CONSIDERATION AND POSSIBLE ACTION TO RAD BY TITLE ONLY, WAIVE FURTHER READING, AND INTRODUCE ORDINANCE AMENDING TITLES 16 AND 17 OF THE MONTEREY PARK MUNICIPAL CODE BY ADOPTING THE 2022 EDITION OF THE CALIFORNIA BUILDING STANDARDS CODE AND THE MONTEREY PARK AMENDMENTS TO THE CALIFORNIA BUILDING STANDARDS CODE; SET PUBLIC HEARING FOR NOVEMBER 16, 2022

Every three years, the State of California adopts new uniform codes that apply to all jurisdictions within California. These are codified in Title 24 of the Code of California Regulations and are commonly referred to as “uniform codes” or the California Building Standards Code (“CBSC”). The 2022 CBSC takes effect on January 1, 2023. California law allows local governments to make limited amendments the CBSC based upon local climatic, topographical, and geological conditions, or for administrative reasons.

If adopted, the proposed Ordinance would incorporate the uniform codes by reference into the MPMC. Additionally, the Ordinance would make limited amendments to these regulations based upon local conditions.

CEQA (California Environmental Quality Act):

Pursuant to the California Environmental Quality Act (“CEQA”) and the CEQA Guidelines, the proposed Ordinance affects commercial development or businesses and is not subject to further review under CEQA for the following reasons: (1) the Ordinance is an action being taken for enhanced environmental protection (14 Cal. Code Regs. § 15308); (2) there is no possibility that the ordinance may have a significant effect on the environment (14 Cal. Code Regs. § 15061(b)(3)); and (3) it will not result in a direct or reasonably foreseeable indirect physical change in the environment (14 Cal. Code Regs. § 15060(c)(2)). The notice of exemption prepared for this project is contained in Attachment 2.

Public Speakers:

- Phil Ciminelli stated that he is currently working on a project in the City and was concerned how the implementation of the new code updates would affect his proposed project.

Action Taken: The City Council read by title only, waiving further reading, and introducing the proposed Ordinance; and scheduled a public hearing on November 16, 2022 for the second reading and adoption of the ordinance.

Motion: Moved by Council Member Liang and seconded by Council Member Yiu, motion carried by the following vote:

Ayes: Council Members: Yiu, Chan, Lo, Liang
Noes: Council Members: None
Absent: Council Members: None
Abstain: Council Members: None

Ordinance, 1st-Reading:

AN ORDINANCE ADOPTING THE 2022 EDITIONS OF THE CALIFORNIA BUILDING CODE, THE CALIFORNIA RESIDENTIAL CODE, THE CALIFORNIA ELECTRICAL CODE, THE CALIFORNIA MECHANICAL CODE, THE CALIFORNIA PLUMBING CODE, THE CALIFORNIA ENERGY CODE, THE CALIFORNIA HISTORICAL CODE, THE CALIFORNIA FIRE CODE, THE CALIFORNIA EXISTING BUILDING CODE, THE CALIFORNIA GREEN BUILDING STANDARDS CODE, THE CALIFORNIA REFERENCED STANDARDS CODE, THE CALIFORNIA BUILDING STANDARDS ADMINISTRATIVE CODE, MAKING CERTAIN AMENDMENTS BASED UPON LOCAL CONDITIONS; AND AMENDING THE MONTEREY PARK MUNICIPAL CODE TO REFLECT SUCH CHANGES

6. CITY COMMUNICATIONS (CITY COUNCIL)

Council Member Yiu attended the Luminarias Grand Opening. She also attended the Library Foundation Dinner Celebrating outgoing Council Members Liang and Chan for their service to the city. Proceeds for the event went to the city's Library.

Council Member Chan attended Monster Mash, Luminarias Grand Opening, Coffee with the Cops, and a Round Table hosted by Assembly Member Mike Fong along with community leaders discussing the ongoing hate crimes against those who are of Asian-American decent. He thanked everyone that came to the Library Foundation Dinner celebrating his time as a Monterey Park City Council Member.

Council Member Liang thanked everyone who attended the Library Foundation Dinner celebrating his time as a Monterey Park City Council Member.

Mayor Lo reported that he attended the Centurion Awards that was presented to the Monterey Park Police Department's N.E.T. Team. He also attended the Monster Mash, Library Foundation Dinner celebrating Council Member Chan and Liang for their service to the city, and a Round Table hosted by Assembly Member Mike Fong along with community leaders discussing the ongoing hate crimes against those who are of Asian-American decent. He suggested everyone in attendance sign Happy Birthday to Council Member Yiu.

7. FUTURE AGENDA ITEMS – None.

8. CLOSED SESSION (IF REQUIRED; CITY ATTORNEY TO ANNOUNCE)
None.

ADJOURNMENT

There being no further business for consideration, the meeting was adjourned at 8:35 p.m.

Vincent D. Chang
City Clerk



City Council Staff Report

DATE: November 16, 2022

AGENDA ITEM NO: Consent Calendar - 3B

TO: The Honorable Mayor and City Council
FROM: Martha Garcia, Director of Management Services
SUBJECT: Resolution Adopting the Recognized Obligation Payment Schedule and Administrative Budget for July 1, 2023 – June 30, 2024

RECOMMENDATION:

It is recommended that the City Council consider:

1. Adopting a resolution approving the Recognized Obligation Payment Schedule (ROPS 23-24 A&B) for the period between July 1, 2023 – June 30, 2024;
2. Approving the Successor Agency Administrative Budget for July 1, 2023 – June 30, 2024;
3. Directing staff to post and transmit the ROPS and Administrative Budget to the appropriate public agencies; and
4. Taking such additional, related, action that may be desirable.

EXECUTIVE SUMMARY:

Existing law requires the Monterey Park Successor Agency (SA) to formulate Recognized Obligation Payment Schedules (ROPS) under which the SA makes payments for eligible obligations of the former Redevelopment Agency. The ROPS are considered by the Successor Agency Board, proposed to the Oversight Board (OB) and, if approved by the OB, provided to the California Department of Finance for review.

The ROPS is required to be prepared for an entire 12 months. Staff requests that the City Council, acting on behalf of the SA for the former Monterey Park Redevelopment Agency, consider and adopt the ROPS 23-24 A&B and the related administrative budget for the period covering July 1, 2023 – June 30, 2024.

BACKGROUND:

ROPS 23-24 A&B has no new line items and requests an amount of \$2,366,056 including an administrative budget of \$190,000 for the period of July 1, 2023 through June 30, 2024.

To meet the deadlines for disbursement of funds from the County of Los Angeles, both the SA and the OB must approve the ROPS and submit it to the Department of Finance by January 31, 2023.

The First District Consolidated Oversight Board is scheduled on January 9, 2023 to review the ROPS as well as the administrative budget after the SA's approval. The deadline for the Successor Agency to the First District Consolidated Oversight Board is December 19, 2022.

FISCAL IMPACT:

All monies received from the request made on the ROPS go into the account of the Successor Agency for obligations of the former Redevelopment Agency.

Respectfully submitted by:



Martha Garcia
Management Services Director

Approved by:

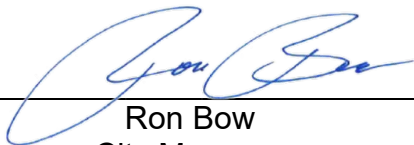

Ron Bow
City Manager

Reviewed by:

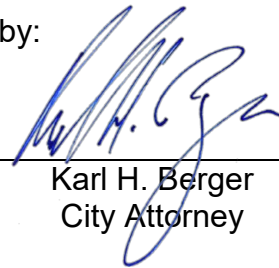

Karl H. Berger
City Attorney

ATTACHMENT:

1. Resolution ROPS 23-24 A&B

ATTACHMENT 1

Resolution ROPS 23-24 A&B

RESOLUTION NO. SA- ____

**A RESOLUTION OF THE SUCCESSOR AGENCY TO THE
MONTEREY PARK REDEVELOPMENT AGENCY ADOPTING
RECOGNIZED OBLIGATION PAYMENT SCHEDULES PURSUANT
TO HEALTH AND SAFETY CODE § 34177.**

The City Council, acting on behalf of the Successor Agency to the Monterey Park Redevelopment Agency (“Successor Agency”), does resolve as follows:

Section 1. The City council finds and declares that:

- A. On June 29, 2011, AB 1X 26 and AB 1 X 27 became effective, requiring that each redevelopment agency within California be dissolved unless the community that created it enacts an ordinance committing it to making certain payments;
- B. On December 29, 2011, the California Supreme Court issued a decision in *California Redevelopment Association v. Matosantos* (2011) 53 Cal. 4th 231 largely upholding AB 1 X 26, invalidating AB 1X 27 as unconstitutional, and holding that AB 1X 26 may be severed from AB 1X 27 and enforced independently;
- C. As a result of the Supreme Court’s decision, the Monterey Park Redevelopment Agency (the “redevelopment agency”), created pursuant to the Community Redevelopment Law, was dissolved pursuant to AB 1X 26 on February 1, 2012;
- D. By its Resolution No. 11455 adopted on January 11, 2012, the City Council of the City of Monterey Park chose to act on behalf of the successor agency for the Redevelopment Agency (the “Successor Agency”); and
- E. In adopting this Resolution for the Successor Agency, the City Council approves the Recognized Obligation Payment Schedule (designated as ROPS 23-24 A&B by the California Department of Finance) on behalf of the Successor Agency for the period from July 1, 2023 through June 30, 2024.

Section 2. *Recognized Obligation Payment Schedules.* The City Council adopts ROPS 23-24 A&B attached as Exhibit “A” to this Resolution and incorporated by reference. The City Council also adopts the Administrative Budget attached as Exhibit “B” to this Resolution and incorporated by reference.

Section 3. Authorization. The City Manager, or designee, acting on behalf of the Successor Agency is authorized and directed, jointly and severally, to implement this Resolution including, without limitation, providing documents associated with the ROPS 23-24 A&B to the Oversight Board, City Council, Department of Finance, county Controller and (if applicable) State Controller. The City Manager, or designee, is the official whom the Department of Finance may make requests for review in connection with the ROPS 23-24 A&B.

Section 4. Amendment. The ROPS may be amended from time-to-time at any public meeting of the City Council acting on behalf of the Successor Agency.

Section 5. Environmental Determination. This Resolution is exempt from review under the California Environmental Quality Act (California Public Resources Code §§ 2100, et seq., "CEQA") and CEQA regulations (14 California Code of Regulations §§ 15000, et seq.) because it establishes rules and procedures to implement government funding mechanisms; does not involve any commitment to a specific project which could result in a potentially significant physical impact on the environment; and constitutes an organizational or administrative activity that will not result in direct or indirect physical changes in the environment. Accordingly, this Resolution does not constitute a "project" that requires environmental review (see specifically 14 CCR § 15378(b)(4-5)).

Section 6. Reliance on Record. Each and every one of the findings and determinations in this Resolution are based on the competent and substantial evidence, both oral and written, contained in the entire record relating to the Successor Agency and applicable law. The findings and determinations constitute the independent findings and determinations of the City Council in all respects and are fully and completely supported by substantial evidence in the record as a whole.

Section 7. Summaries of Information. All summaries of information in the findings, which precede this Section, are based on the substantial evidence in the record including, without limitation, verbal and documentary evidence submitted to the Successor Agency. The absence of any particular fact from any such summary is not an indication that a particular finding is not based in part on that fact.

Section 8. Electronic Signatures. This Resolution may be executed with electronic signatures in accordance with Government Code §16.5. Such electronic signatures will be treated in all respects as having the same effect as an original signature.

Section 9. The Secretary is directed to certify the adoption of this Resolution; record this Resolution in the book of the SA's original resolutions; and make a minute of the adoption of the resolution in the Successor Agency's records and the minutes of this meeting.

Section 10. This Resolution will become effective immediately upon adoption and will remain effective unless repealed or superseded.

PASSED, APPROVED, AND ADOPTED this 16th day of November 2022.

Henry Lo, Mayor
Monterey Park, California

ATTEST:

Vincent D. Chang, City Clerk
Monterey Park, California

APPROVED AS TO FORM:

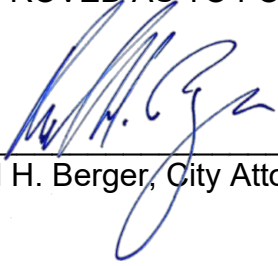

Karl H. Berger, City Attorney

STATE OF CALIFORNIA)
COUNTY OF LOS ANGELES) ss.
CITY OF MONTEREY PARK)

I, Vincent D. Chang, hereby certify that the above foregoing Resolution No. SA-____ was duly passed and adopted by the City Council acting on behalf of the Successor Agency to the former Redevelopment Agency at a regular meeting held on the 16th day of November, 2022 by the following vote:

AYES:	Council Members:
NOES:	Council Members:
ABSTAIN:	Council Members:
ABSENT:	Council Members:

Dated this 16th day of November, 2022

Vincent D. Chang, City Clerk
City of Monterey Park

Monterey Park
ROPS 2023-24 Annual

Requested Funding for Obligations		23-24A Total	23-24B Total	ROPS Total
A	Obligations Funded as Follows (B+C+D)	0	0	0
B	Bond Proceeds	0	0	0
C	Reserve Balance	0	0	0
D	Other Funds	0	0	0
E	Redevelopment Property Tax Trust Fund (RPTTF) (F+G)	1,182,903	1,183,153	2,366,056
F	RPTTF	1,087,903	1,088,153	2,176,056
G	Administrative RPTTF	95,000	95,000	190,000
H	Current Period Obligations (A+E)	1,182,903	1,183,153	2,366,056

Monterey Park ROPS 2023-24 Annual								Total Outstanding Obligation	Total Requested Funding
Item #	Obligation Name	Obligation Type	Agreement Execution Date	Agreement Termination Date	Payee	Description			
1	Successor Agency Administration Costs	Admin Costs	1/1/2014	7/12/2034	Successor Agency	Successor Agency Administration Costs - labor and overhead	35,896,622	190,000	
28	Housing Fund Repayment of SERAF Loan	LMIHF Loans	8/4/2010	6/30/2016	Housing Successor Agency	Housing Fund Repayment of SERAF Loan	1,102,348	137,342	
29	Repayment of Housing Loan Obligation	LMIHF Loans	5/19/1997	6/30/2039	Housing Successor Agency	Housing Fund Repayment for Outstanding Loan	1,186,222	-	
31	Atlantic-Garvey Tax Allocation Refunding Bonds, 2013A	Bonds Issued On or Before 12/31/10	12/24/2013	9/1/2026	US Bank	Bonds issued to advance refund the 2002 Tax Allocation Bonds	4,690,559	1,376,757	
32	Trustee Fees for Merged Tax Allocation Refunding Bonds, 2013B	Bonds Issued On or Before 12/31/10	12/24/2013	9/1/2028	US Bank	Fees for Trustee of Refunding Bonds	23,250	1,000	
33	Trustee Fees for Atlantic-Garvey Tax Allocation Refunding Bonds, 2013A	Bonds Issued On or Before 12/31/10	12/24/2013	9/1/2026	US Bank	Fees for Trustee of Refunding Bonds	24,620	1,000	
36	Merged Tax Allocation Refunding Bonds, 2013B	Bonds Issued After 12/31/10	12/24/2013	9/1/2028	US Bank	Bonds issued to advance refund the 1998 Tax Allocation Bonds	4,260,302	659,957	
								2,366,056	

Monterey Park Recognized Obligation Payment Schedule (ROPS 23-24) - Report of Cash Balances
July 1, 2020 through June 30, 2021
(Report Amounts in Whole Dollars)

Pursuant to Health and Safety Code section 34177 (I), Redevelopment Property Tax Trust Fund (RPTTF) may be listed as a source of payment on the ROPS, but only to the extent no other funding source is available or when payment from property tax revenues is required by an enforceable obligation. For tips on how to complete the Report of Cash Balances Form, see [Cash Balance Tips](#).

A	B	C	D	E	F	G	H
		Fund Sources					
		Bond Proceeds		Reserve Balance	Other Funds	RPTTF	
	ROPS 20-21 Cash Balances (07/01/20 - 06/30/21)	Bonds issued on or before 12/31/10	Bonds issued on or after 01/01/11	Prior ROPS RPTTF and Reserve Balances retained for future period(s)	Rent, Grants, Interest, etc.	Non-Admin and Admin	Comments
1	Beginning Available Cash Balance (Actual 07/01/20) RPTTF amount should exclude "A" period distribution amount					0	
2	Revenue/Income (Actual 06/30/21) RPTTF amount should tie to the ROPS 20-21 total distribution from the County Auditor-Controller					2,434,306	
3	Expenditures for ROPS 20-21 Enforceable Obligations (Actual 06/30/21)					2,434,306	
4	Retention of Available Cash Balance (Actual 06/30/21) RPTTF amount retained should only include the amounts distributed as reserve for future period(s)						
5	ROPS 20-21 RPTTF Prior Period Adjustment RPTTF amount should tie to the Agency's ROPS 20-21 PPA form submitted to the CAC	No entry required					
6	Ending Actual Available Cash Balance (06/30/21) C to F = (1 + 2 - 3 - 4), G = (1 + 2 - 3 - 4 - 5)	\$ 0	\$ 0	\$ 0	\$ 0	\$ 0	

**City of Monterey Park
 Successor Agency Administrative Costs
 7/1/2023 - 6/30/2024**

			ROPS 23-24 A&B 12-Month Period
Object	ROPS Item #	Name	Total
<i>Successor Agency</i>			
5103*	1	Salaries & Benefits:	
		Accountant	25,000
		Director of Mgmt Services	35,000
		City Manager	30,000
		<i>Sub-total for Salaries and Benefits</i>	90,000
5111/5402*		General Liability / Insurance / Separation Benefits	22,000
5404		OPEB Obligations	12,000
5308		Office Supplies (paper/toners/ink)	1,000
5272/5303		Postage / Messenger Service / Telephone	1,000
5227		Attorney Services	5,000
5210		SA Audit and Annual Financial Statement	22,000
5211/5405		Other Professional Services	15,000
5260		Duplicating Equipment Rental	5,000
5211/5254*		Repairs and Maintenance (Space)	17,000
<i>Administration Budget - Total</i>			\$ 190,000



City Council Staff Report

DATE: November 16, 2022

AGENDA ITEM NO: Consent Calendar - 3C

TO: The Honorable Mayor and City Council
FROM: Joseph Leon, City Treasurer
SUBJECT: Monthly Investment Report – October 2022

RECOMMENDATION:

It is recommended that the City Council consider:

1. Receiving and filing the monthly investment report; and
2. Taking such additional, related, action that may be desirable.

EXECUTIVE SUMMARY:

As of October 31, 2022 invested funds for the City of Monterey Park is \$79,910,449.67.

BACKGROUND:

In accordance with the City's Investment Policy, a monthly investment report is presented to the City Council showing the types of investments, dates of maturities, amounts of deposits, rates of interest, and the current market values for securities with maturity more than 12 months. The attached monthly investment report includes a summary investment report for the LA County Pooled Investment Fund, which displays the composition by type for the entire pooled investment fund.

Respectfully submitted by:

Handwritten signature of Joseph Leon in black ink.

Joseph Leon
City Treasurer

Prepared by:

Handwritten signature of Martha Garcia in blue ink.

Martha Garcia
Director of Management Services

Approved by:

Handwritten signature of Ron Bow in blue ink.

Ron Bow
City Manager

Attachment 1

Monthly Investment Report

**CITY OF MONTEREY PARK
INVESTMENT REPORT
OCTOBER 31, 2022**

INVESTMENTS PORTFOLIO PROFILE:

TOTAL BALANCE AT 10/31/2022

\$ 79,910,449.67

INVESTMENT COMPOSITION

(1)	<u>LA COUNTY POOLED INVESTMENT FUND</u> <i>(See Schedule A for LA County Pool Composition)</i>	ON DEMAND	1.950%	<u>\$ 42,979,212.92</u>
(2)	<u>LOCAL AGENCY INVESTMENT FUND</u>	ON DEMAND	1.750%	<u>\$ 30,066,236.75</u>

(3)	<u>CERTIFICATES OF DEPOSIT</u>	<u>Purchase Date</u>	<u>Maturity Date</u>	<u>Interest Rate</u>	
1	PREFERRED BANK	09/03/22	09/03/23	2.51%	100,000
2	PREFERRED BANK	09/08/22	09/08/23	2.67%	150,000
3	SALLIE MAE BANK	08/11/21	08/12/24	0.70%	245,000
4	GOLDMAN SACHS BANK	08/11/21	08/12/24	0.60%	245,000
5	TOYOTA FINANCIAL SAVINGS BANK	09/16/21	09/16/24	0.65%	245,000
6	BMW BANK NORTH AMERICA	09/17/21	09/17/24	0.65%	245,000
7	SYNCHRONY BANK	09/17/21	09/17/24	0.65%	245,000
8	UBS BANK USA	09/22/21	09/23/24	0.65%	245,000
9	STATE BANK OF INDIA	10/18/21	10/18/24	0.70%	245,000
10	LIVE OAK BANKING CO.	01/14/22	01/16/24	0.70%	245,000
11	GREENSTATE CREDIT UNION	01/14/22	01/16/24	0.70%	245,000
12	BEAL BANK USA	01/19/22	01/17/24	0.70%	245,000
13	MEDALLION BANK UTAH	01/28/22	01/28/25	1.25%	245,000
14	PENTAGON FEDERAL UNION	01/31/22	01/31/25	1.25%	245,000
15	BEAL BANK	02/02/22	01/29/25	1.15%	245,000
16	AMERICAN EXPRESS NATL BANK	03/09/22	03/11/24	1.60%	245,000
17	BARCLAYS BANK DELAWARE	03/09/22	03/11/24	1.55%	245,000
18	CAPITAL ONE BANK USA	03/16/22	03/17/25	1.80%	245,000
19	VALLIANCE BANK	03/18/22	03/18/25	1.40%	245,000
20	STATE BANK OF TEXAS	03/25/22	03/25/25	1.45%	245,000
21	FIRST FED SAVINGS & LOAN	03/30/22	03/31/25	2.00%	245,000
22	LAFAYETTE FEDERAL CREDIT UNION	03/30/22	03/31/25	2.20%	245,000
23	ALLY BANK	03/31/22	03/28/24	1.95%	245,000
24	COMENITY CAPITAL BANK	04/14/22	04/14/25	2.55%	245,000
25	AMERICU CREDIT UNION	04/21/22	04/21/25	2.30%	245,000
26	BALBOA THRIFT & LOAN	04/29/22	04/29/25	2.00%	245,000
27	CONNEXUS CREDIT UNION	05/26/22	05/28/24	2.65%	245,000
28	METRO CREDIT UNION	07/13/22	07/12/24	3.20%	245,000
29	FIRST TECHNOLOGY CREDIT UNION	8/5/2022	08/05/24	3.25%	245,000
	<i>Total CDs (29)</i>			1.567%	<u>\$ 6,865,000.00</u>

OTHER INFORMATION:

BANK BALANCE: ⁽¹⁾ **\$ 4,703,283.48**

AVERAGE MATURITY DAYS 61

AVERAGE INTEREST RATE FOR THE MONTH 1.839%

THE CITY'S INVESTMENT HAS SUFFICIENT LIQUIDITY TO MEET THE CITY'S EXPENDITURE REQUIREMENTS FOR THE NEXT 180 DAYS. THE 180-DAY LIQUIDITY DISCLOSURE IS REQUIRED PER GOVERNMENT CODE 53646.

INTEREST EARNINGS FOR 1ST QTR 2022-2023 **\$ 270,308.50**

THERE HAVE BEEN NO VARIANCES TO THE INVESTMENT POLICY.

*(1) Bank balance is maintained to cover outstanding warrants, payroll checks and on-going operating costs. **Page 58 of 306***

**POOLED SURPLUS AND SPECIFIC PURPOSE INVESTMENTS
AS OF SEPTEMBER 30, 2022**

SCHEDULE A

<u>PORTFOLIO PROFILE</u>	<u>Pooled Surplus Investments</u>	<u>Specific Purpose Investments</u>
Inventory Balance at 09/30/22		
At Cost	\$ 42,057,982,643	\$ 156,766,413
At Market	\$ 39,187,124,392	\$ 133,385,212
Repurchase Agreements	\$ -	\$ -
Reverse Repurchase Agreements	\$ -	\$ -
Composition by Security Type:		
Certificates of Deposit	4.87%	0.00%
United States Government and Agency Obligations	71.44%	72.26%
Bankers Acceptances	0.00%	0.00%
Commercial Paper	23.59%	0.00%
Municipal Obligations	0.07%	1.82%
Corporate and Deposit Notes	0.03%	0.00%
Repurchase Agreements	0.00%	0.00%
Asset-Backed	0.00%	0.00%
Other	0.00%	25.92%
1-60 days	35.21%	0.00%
61 days-1 year	19.40%	25.92%
Over 1 year	45.39%	74.08%
Weighted Average Days to Maturity	1,008	



City Council Staff Report

DATE: November 16, 2022

AGENDA ITEM NO: Consent Calendar - 3D

TO: The Honorable Mayor and City Council
FROM: Martha Garcia, Director of Management Services
SUBJECT: A Resolution Amending the Monterey Park Administrative Code by Changing “Management Services Department” to “Finance Department” and Reorganizing the Finance Department

RECOMMENDATION:

It is recommended that the City Council consider:

1. Adopting a Resolution amending the Monterey Park Administrative Code by Changing “Management Services Department” to “Finance Department” and reorganizing the Finance Department; and
2. Take additional, related, action that may be desirable.

ENVIRONMENTAL REVIEW:

The proposed action is exempt from review under the California Environmental Quality Act (California Public Resources Code §§ 21000, *et seq.*, “CEQA”) and CEQA regulations (14 California Code of Regulations (“CCR”) §§ 15000, *et seq.*) because it establishes rules and procedures to clarify existing policies and practices related to government organization; does not involve any commitment to a specific project which could result in a potentially significant physical impact on the environment; and constitutes an organizational or administrative activity that will not result in direct or indirect physical changes in the environment. Accordingly, the action does not constitute a “project” that requires environmental review (see specifically 14 CCR § 15378(b)(4-5)).

BACKGROUND:

On June 15, 2022, the City Council adopted Resolution No. 2022-R47 that constitutes the Monterey Park Administrative Code (the “Administrative Code”). The Administrative Code establishes the organization and operations for all City departments. Section 4 of the Administrative Code establishes the “Management Services Department” which operates under the supervision of the Management Services Director. During the past two years, the City’s efforts to become more efficient resulted in the Management Services Department transferring various functions to other City Departments. Rather than supporting those

Departments, it has transitioned to focusing primarily on the City’s financial functions. These now mirror those contemplated by Monterey Park Municipal Code (“MPMC”) Chapter 3.04 which creates the “Office of Director of Finance.”

These changes include, without limitation, the following:

- Decentralization of procurement services;
- Outsourcing of business license processing;
- Decentralization of contracts;
- Transfer of janitorial services to the Public Works Department; and
- Transfer of desk and mobile phone services to the IT Division.

If adopted, the draft Resolution would amend Section 4 of the Administrative Code to reconcile the Management Service Department with (1) the MPMC and (2) current City practices. This includes the renaming of the Department to the “Finance Department” and its reorganization to reflect current operations and practice. Those changes will also result in amendments to the City’s Administrative Policies and Procedures (“AP&P”) regulating purchasing goods and services. The Resolution will authorize the City Manager to implement those changes and, additionally, make proposed changes to the MPMC and Operating Budget reflecting the changes in organization.

Respectfully Submitted and prepared by:

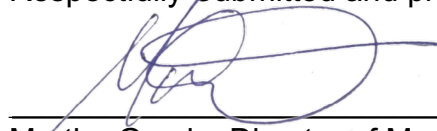

Martha Garcia, Director of Management Services

Approved by:



Ron Bow, City Manager

Reviewed by:

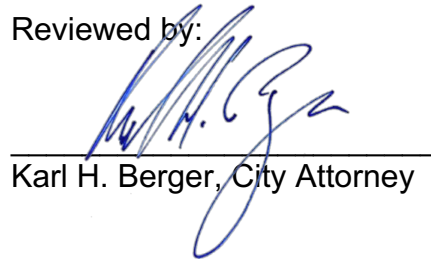

Karl H. Berger, City Attorney

Attachment(s)

1. Resolution No. 2022-R47
2. MPMC Chapter 3.04
3. Draft Resolution

ATTACHMENT 1
Resolution No. 2022-R47

RESOLUTION NO. 2022-R47

A RESOLUTION AMENDING THE PREVIOUSLY ADOPTED MONTEREY PARK ADMINISTRATIVE CODE ESTABLISHING CITY DEPARTMENTS, IDENTIFYING DEPARTMENT DIRECTORS, AND IMPLEMENTING DEPARTMENT RESPONSIBILITIES.

The Council of the City of Monterey Park does resolve as follows:

SECTION 1: Purpose. This Resolution is adopted pursuant to Section 5 of Resolution No. 12200 (adopted September 16, 2020) to reflect changes made to the City's administration implemented by the City Manager since 2020. Resolution No. 12200, as amended by Resolution No. 12209 (adopted November 4, 2020), constitutes the "Monterey Park Administrative Code."

SECTION 2: Incorporation of Previous Resolutions. Unless specifically provided in this Resolution, the definitions, construction, delegation of authority, and authority to make administrative changes reflected in the Monterey Park Administrative Code are incorporated by reference into this Resolution without restatement.

SECTION 3: Organization and Operation. In addition to any powers delegated by applicable law including the MPMC, the City Manager is the City officer responsible for directing and supervising the administration of all departments, offices and agencies of the City, and is responsible for the general overall administration of City government. This office is also responsible for coordinating intergovernmental relations and promoting community relations and economic vitality. Unless the City Manager subsequently transfers supervisory authority to a different Department, the City Manager will directly supervise the following divisions:

- A. **City Clerk.** While the City Clerk is an elected official, the City employees within the City Clerk's office are supervised by the City Manager, or designee, on a day-to-day basis.
- B. **Economic Development Division.** The City Manager, or designee, directly supervises:
 - 1. Economic Development;
 - 2. CDBG Administration;
 - 3. HOME housing program;
 - 4. Affordable housing program; and
 - 5. Business improvement area.

SECTION 4: Management Services Department.

- A. **Organization.** The Management Services Department is established under the direction and administration of the Management Services Director. These areas are:
1. Finance;
 2. Information Technology;
 3. Revenue Collection;
 4. Central Support Services; and
 5. Community Housing Assistance.
- B. **Establishment of Funds and Accounts.** The following City funds are established:
1. General Fund - The General Fund is established as a medium of control of and accounting for municipal activities other than activities authorized or contemplated by special funds or other governmental funds. All revenues and receipts which are not by law or otherwise pledged or encumbered for special purposes will be credited to the General Fund.
 2. Special Revenue Funds - Special Revenue Funds will be established to account for revenues designated for particular purposes under the governmental funds group.
 3. Capital Projects Funds - Capital Projects Funds will be established to account for all revenues designated for the acquisition of capital facilities except those facilities financed by special assessment.
 4. Debt Service Fund - A Debt Service Fund within the governmental fund group and in each proprietary fund, as appropriate, will be established to service the revenue and expense accounts devoted to the payment of interest and principal on long-term revenues and general obligation debt other than that payable from special assessments.
 5. Trust Funds - Trust Funds will be established to account for revenues held by the City as a trustee.
 6. Internal Service Funds - Internal Service Funds may be established to provide services efficiently and economically to other funds or departments and be accounted for under proprietary fund rules.

7. Special Assessment Funds - Special Assessment Funds will be established to account for the construction of public improvements that are financed by special levies against properties adjudged to receive benefits different than those received by the city residents, and for the maintenance and upkeep of such assets.
8. Enterprise Funds - Enterprise Funds will be established as proprietary funds with full accrual accounting that specialize in providing for utility or other fee-supported services to the public. These funds include water, wastewater, and solid waste.
9. Petty Cash Account - A Petty Cash Account will be established as an interest cash account in an amount to be fixed by finance departmental policy. These funds are set aside for the purpose of making change or paying small obligations for which the issuance of a formal voucher and check could be too expensive and time consuming. The annual audit of City funds provides for a review of these disbursements.
10. Groups of Accounts - The City may employ self-balancing groups of accounts. These groups are general fixed assets group and general long-term debt group for governmental funds.

SECTION 5: *Department of Recreation and Community Services.* A Department of Recreation and Community Services is established under the direction and administration of the Recreation and Community Services Director. These areas are:

- A. Facilities Supervision;
- B. Aquatics;
- C. Langley Center;
- D. Youth Activities;
- E. Recreational Activities;
- F. Community Participation; and
- G. Community Transportation.

SECTION 6: *Police Department.* The Police Department is established under the direction and administration of the Chief of Police. These areas include:

- A. Administration;
- B. Community Engagement;
- C. Traffic Bureau;
- D. Field Services;
- E. Investigations;
- F. Animal Services;
- G. Communications;
- H. Jail;
- I. Records; and
- J. Computer Services.

SECTION 7: Fire Department. The Fire Department is established under the direction and administration of the Fire Chief. These areas include:

- A. Administration;
- B. Prevention. Prevention is responsible for the implementation of a Building and Safety program, Fire Prevention program, Hazardous and Toxic Materials regulatory program;
- C. Emergency Operations. Emergency Operations is responsible for the protection of life and property through the quick and effective extinguishment of fires, delivery of emergency medical services to victims of sudden illness and injury, mitigation of toxic and hazardous materials emergencies, response to a variety of emergency conditions which may threaten lives and property of the public, the planning and coordination of a City-wide disaster preparedness program, and the delivery of information and educational programs to the public;
- D. Emergency Medical Services;
- E. Community Risk Reduction; and
- F. Code Enforcement. Code Enforcement is responsible for a general enforcement program, Housing Rehabilitation program, Public

Education program and other activities related to permitting, plan checking, inspections and the enforcement of community standards.

SECTION 8: *Public Works Department.* A Public Works Department is established under the direction and administration of the Public Works Director. These areas are:

- A. Community transportation;
- B. Street and Alley maintenance;
- C. Storm drain maintenance;
- D. Sanitary sewer maintenance;
- E. Street cleaning;
- F. Traffic control, Signage and Striping;
- G. Street lighting;
- H. Refuse collection;
- I. Administration;
- J. Water Commercial;
- K. Water Production;
- L. Water Distribution;
- M. Water Capital Projects;
- N. Parkway and City Tree inventory maintenance;
- O. Parks;
- P. Building Maintenance;
- Q. Motor Pool Shop; and
- R. Engineering;

SECTION 9: *Human Resources and Risk Management Department.* A Department of Human Resources and Risk Management is established under the

direction and administration of the Human Resources and Risk Management Director. Under the direction of the Human Resources Director, the Department is responsible for recruitment and selection, classification, compensation and benefits, training, employee relations and labor negotiations, and risk management.

SECTION 10: ***Community Development Department.*** A Department of Community Development is established under the direction and administration of the City Planner or Community Development Director. These areas are:

- A. Planning; and
- B. Building and Safety.

SECTION 11: ***Library.*** A Library is established in accordance with the MPMC under the direction and administration of the Librarian. The Library is divided into the following areas:

- A. Administration;
- B. Reference and Adult Services;
- C. Technical Services and Circulation;
- D. Literacy; and
- E. Children’s Services.

SECTION 12: ***Effect of Reorganization.*** Any new titles for departments, divisions, department heads and division heads as enacted by this Resolution supersede and replace any inconsistent terms, titles, or references appearing in previously enacted City of Monterey Park Ordinances, Resolutions, AP&P, and written policies.

SECTION 13: ***Environmental Review.*** This resolution is exempt from review under the California Environmental Quality Act (California Public Resources Code §§ 21000, *et seq.*, “CEQA”) and CEQA regulations (14 California Code of Regulations (“CCR”) §§ 15000, *et seq.*) because it establishes rules and procedures to clarify existing policies and practices related to government organization; does not involve any commitment to a specific project which could result in a potentially significant physical impact on the environment; and constitutes an organizational or administrative activity that will not result in direct or indirect physical changes in the environment. Accordingly, this Resolution does not constitute a “project” that requires environmental review (see specifically 14 CCR § 15378(b)(4-5)).

SECTION 14: **Conflicts.** In the event of a conflict between the provisions of this Resolution and the provisions the MPMC, any other resolution, or any resolution, the provisions of this Resolution govern. The City Manager is authorized to resolve any ambiguities. Any such determination must be forwarded to the City Council as an informational item when practicable.

SECTION 15: **Electronic Signatures.** This Resolution may be executed with electronic signatures in accordance with Government Code §16.5. Such electronic signatures will be treated in all respects as having the same effect as an original signature.

SECTION 16: **Construction.** This Resolution must be broadly construed in order to achieve the purposes stated in this Resolution. It is the City Council's intent that the provisions of this Resolution be interpreted or implemented by the City and others in a manner that facilitates the purposes set forth in this Resolution.

SECTION 17: **Recordation.** The Mayor, or presiding officer, is authorized to sign this Resolution signifying its adoption by the City Council of the City of Monterey Park and the City Clerk, or her duly appointed deputy, may attest thereto.

SECTION 18: **Effective Date.** This Resolution will become effective immediately upon adoption and will remain effective unless repealed or superseded.

PASSED AND ADOPTED this 15th day of June 2022.

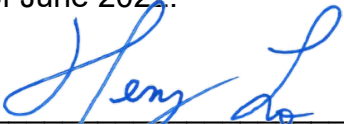

Henry Lo, Mayor

ATTEST:

Vincent D. Chang, City Clerk

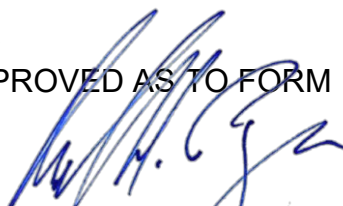
APPROVED AS TO FORM

Karl H. Berger, City Attorney

STATE OF CALIFORNIA)
COUNTY OF LOS ANGELES) §
CITY OF MONTEREY PARK)

I, Vincent D. Chang, City Clerk of the City of Monterey Park, California, do hereby certify that the foregoing Resolution No. 2022-R47 was duly adopted and passed at a regular meeting of the Monterey Park City Council on the 15th day of June, 2022 by the following vote:

Ayes:	Council Members: Yiu, Chan, Liang, Lo
Noes:	Council Members: None
Abstain:	Council Members: None
Absent:	Council Members: None

Dated this 15th day of June, 2022.

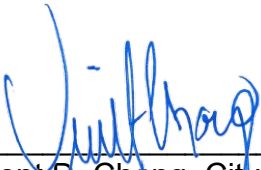

Vincent D. Chang, City Clerk
Monterey Park, California

Monterey Park, California Municipal Code

Title 3 REVENUE AND FINANCE

Chapter 3.04 DIRECTOR OF FINANCE

3.04.010 Office established.

3.04.020 Powers—Duties.

3.04.030 Bond.

3.04.010 Office established.

There is created and established the office of director of finance. (Prior code § 2380)

3.04.020 Powers—Duties.

The director of finance shall be the head of the finance department of the city and shall have the power and shall be required to:

- (1) Have charge of the administration of the financial affairs of the city under the direction of the city manager;
- (2) Compile the budget expense and income estimates for the city manager;
- (3) Maintain a general accounting system for the city government and each of its offices, departments and agencies;
- (4) Supervise and be responsible for the disbursement of all moneys and have control of all expenditures to insure that budget appropriations are not exceeded; audit all purchase orders before issuance; audit and approve before payment, all bills, invoices, payrolls, demands or charges against the city government and, with the advice of the city attorney, when necessary, determine the regularity, legality and correctness of such claims, demands or charges;
- (5) Submit to the city council through the city manager a monthly statement of all receipts and disbursements in sufficient detail to show the financial condition of the city; and, as of the end of each fiscal year, submit a complete financial statement and report;
- (6) Supervise the keeping of current inventories of all property of the city by all city departments, offices and agencies;
- (7) Perform all the financial and accounting duties imposed upon the city clerk by Article 1 of Chapter 4, Part 2, Division 3, Title 4 and by Sections 40802 through 40805 of the [Government Code](#) of the state;

RESOLUTION NO. __

A RESOLUTION AMENDING SECTION 4 OF RESOLUTION NO. 2022-R47 TO RENAME THE “MANAGEMENT SERVICES DEPARTMENT” TO “FINANCE DEPARTMENT” AND IMPLEMENT CERTAIN ORGANIZATION CHANGES TO THE FINANCE DEPARTMENT.

The Council of the City of Monterey Park does resolve as follows:

SECTION 1: Section 4 to Resolution No. 2022-R47 is amended to read as follows:

~~“Management Services~~Finance Department.

A. **Organization.** The ~~Management Services~~Finance Department is established under the direction and administration of the ~~Management Services~~Finance Director. These areas are:

1. Finance;
2. Information Technology;
3. Revenue Collection; and
- ~~4. Central Support Services; and~~
- 5.4. Community Housing Assistance.

B. **Establishment of Funds and Accounts.** The following City funds are established:

1. General Fund – The General Fund is established as a medium of control of and accounting for municipal activities other than activities authorized or contemplated by special funds or other governmental funds. All revenues and receipts which are not by law or otherwise pledged or encumbered for special purposes will be credited to the General Fund.
2. Special Revenue Funds – Special Revenue Funds will be established to account for revenues designated for particular purposes under the governmental funds group.
3. Capital Projects Funds – Capital Projects Funds will be established to account for all revenues designated for the acquisition of capital facilities except those facilities financed by special assessment.
4. Debt Service Fund – A Debt Service Fund within the governmental fund group and in each proprietary fund, as appropriate, will be established to service the revenue and

- expense accounts devoted to the payment of interest and principal on long-term revenues and general obligation debt other than that payable from special assessments.
5. Trust Funds – Trust Funds will be established to account for revenues held by the City as a trustee.
 6. Internal Service Funds – Internal Service Funds may be established to provide services efficiently and economically to other funds or departments and be accounted for under proprietary fund rules.
 7. Special Assessment Funds - Special Assessment Funds will be established to account for the construction of public improvements that are financed by special levies against properties adjudged to receive benefits different than those received by the city residents, and for the maintenance and upkeep of such assets.
 8. Enterprise Funds - Enterprise Funds will be established as proprietary funds with full accrual accounting that specialize in providing for utility or other fee-supported services to the public. These funds include water, wastewater, and solid waste.
 9. Petty Cash Account - A Petty Cash Account will be established as an interest cash account in an amount to be fixed by finance departmental policy. These funds are set aside for the purpose of making change or paying small obligations for which the issuance of a formal voucher and check could be too expensive and time consuming. The annual audit of City funds provides for a review of these disbursements.
 10. Groups of Accounts - The City may employ self-balancing groups of accounts. These groups are general fixed assets group and general long-term debt group for governmental funds.”

SECTION 2: Effect of Reorganization; Authority.

- A. The City Council intends that this Administrative Code be reconciled with Monterey Park Municipal Code (“MPMC”) Chapter 3.04. While the MPMC is being reviewed by the City Manager, as directed by this Resolution, the “office of the director of finance” will be interpreted as the “Finance Department.” Any mention of a

function changed by this Resolution in the MPMC will be interpreted to mean in accordance with the Finance Director, or designee.

- B. The City Manager is directed to review the MPMC and provide the City Council with recommended amendments to reconcile this Administrative Code with the MPMC.
- C. Any new titles for departments, divisions, department heads and division heads as enacted by this Resolution supersede and replace any inconsistent terms, titles, or references appearing in previously enacted City of Monterey Park Ordinances, Resolutions, and written policies.

SECTION 3: *Environmental Review.* This resolution is exempt from review under the California Environmental Quality Act (California Public Resources Code §§ 21000, *et seq.*, “CEQA”) and CEQA regulations (14 California Code of Regulations (“CCR”) §§ 15000, *et seq.*) because it establishes rules and procedures to clarify existing policies and practices related to government organization; does not involve any commitment to a specific project which could result in a potentially significant physical impact on the environment; and constitutes an organizational or administrative activity that will not result in direct or indirect physical changes in the environment. Accordingly, this Resolution does not constitute a “project” that requires environmental review (see specifically 14 CCR § 15378(b)(4-5)).

SECTION 4: *Conflicts.* In the event of a conflict between the provisions of this Resolution and the provisions the MPMC, any other resolution, or any resolution, the provisions of this Resolution govern. The City Manager is authorized to resolve any ambiguities. Any such determination must be forwarded to the City Council as an informational item when practicable.

SECTION 5: *Electronic Signatures.* This Resolution may be executed with electronic signatures in accordance with Government Code §16.5. Such electronic signatures will be treated in all respects as having the same effect as an original signature.

SECTION 6: *Construction.* This Resolution must be broadly construed in order to achieve the purposes stated in this Resolution. It is the City Council’s intent that the provisions of this Resolution be interpreted or implemented by the City and others in a manner that facilitates the purposes set forth in this Resolution.

SECTION 7: *Recordation.* The Mayor, or presiding officer, is authorized to sign this Resolution signifying its adoption by the City Council of the City of Monterey Park and the City Clerk, or her duly appointed deputy, may attest thereto.

SECTION 8: *Effective Date.* This Resolution will become effective immediately upon adoption and will remain effective unless repealed or superseded.

PASSED AND ADOPTED this ____ day of November 2022.

Henry Lo, Mayor

ATTEST:

Vincent D. Chang, City Clerk

APPROVED AS TO FORM

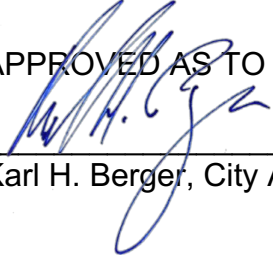

Karl H. Berger, City Attorney



City Council Staff Report

DATE: November 16, 2022

AGENDA ITEM NO: Consent Calendar - 3E

TO: The Honorable Mayor and City Council
FROM: Joseph Torres, Economic Development Manager
SUBJECT: Schedule a Public hearing for consideration of a resolution of the City Council of the City of Monterey Park, California confirming the 2022 Annual Report and the levy of assessments for Downtown Business Improvement District No. 1 for program year 2023.

RECOMMENDATION:

It is recommended that the City Council consider:

1. Receiving and filing the 2022 BID Annual Report with the City Clerk.
2. Adopting the Resolution of Intent and set the Public Hearing for December 7, 2022, for consideration of the 2023 BID assessments and
3. Taking such additional, related, action that may be desirable.

EXECUTIVE SUMMARY:

The Business Improvement District No. 1 (BID) was established in 1986 in accordance with the Parking and Business Improvement Area Law of 1989 (Streets and Highways Code §§ 36000-36004). The BID in the following discussion is business-based, meaning that an assessment is collected from businesses based upon fees rather than real property.

California law requires the BID to file an annual report with the City Clerk summarizing its activities and expenditures for the past year and proposing its budget for the upcoming year. The law also requires the BID assessments to be renewed annually after conducting a public hearing. The Advisory Committee to the BID requested that the City Council set a public hearing to consider the 2023 Levy of Assessment Fees. The BID Advisory Committee is not seeking an increase in assessments for the 2023 program year to help the businesses in the BID weather the financial burdens brought on by the COVID-19 pandemic.

Annual revenue and expenditures may be found within the 2022 Annual Report attached as Attachment 2 or at the City Clerk's office where it is available for viewing.

BACKGROUND:

The Business Improvement District Advisory Committee (BIDAC) is the advisory board to the City Council, entrusted with providing it with feedback on the needs of the businesses within the BID. In addition, it is responsible for providing an annual report to the City Council. The BID was originally managed by an independent business association but was later replaced by the City Council with a City committee consisting of business owners within the assessed area.

In accordance with BID law, the BIDAC is submitting its 2022 Annual Report for Business Improvement District No. 1 that identifies activities and expenditures during the 2022 Program Year and describes the proposed programs and budget for the upcoming 2023 Program year.

On November 1, 2022, the BIDAC conducted its annual members meeting, which was held at Jardin El Encanto. Notices were sent to all BID merchants inviting them to attend the meeting and express their concerns or ideas for programming and budgeting. The purpose of the meeting was to review the Annual Report and receive feedback on the 2022 expenditures and the proposed 2023 budget and assessment fee schedule.

The significant expenditure in 2022 was the installation of Holiday decorations for Garvey Avenue and janitorial services for the downtown area. In addition, a new janitorial services contractor was secured in late 2020. Up until 2021, the BID had experienced several years of expenditures exceeding the annual revenue, mainly due to the escalating costs of janitorial services provided by Chrysalis Enterprises. In December 2020, the City took steps to reduce BID expenditures by terminating the Chrysalis maintenance contract. The City then added the BID janitorial services to the City's existing contract with Valley Maintenance Corporation effective December 1, 2020, through December 31, 2023, providing the BID area with janitorial services four days a week at a significant cost reduction of 64% year-over-year. In 2022, the City added the cleaning of the Downtown parking lot on Garvey and Garfield to the Valley Maintenance contract with the same significantly reduced rate. As of September 2022, the BID has received approximately \$41,841.00 in assessments and expects not to exceed its annual revenue with September 2022 year-to-date expenditures at \$34,768.39.

The BIDAC is proposing its 2023 BID programs and budget. The proposed 2023 Budget is included in the 2022 Annual Report.

Several goals for the upcoming 2023 BID Program include, without limitation:

- Continue to work with the Downtown Garvey - Garfield businesses on ways they can assist in keeping the area attractive.
- Continue Valley Maintenance Corporation janitorial services at a reduced cost for the BID area.

- Install holiday decorations along Garvey Avenue, then remove and place in storage.
- Work with the City to provide workshops and other business assistance activities for businesses in the BID area.
- Support city projects that benefit the BID area such as discussions on the need for assisting businesses in the downtown area post-pandemic, signage, and maintenance.

The 2022 Annual Report, Exhibit E, reflects the fee schedule recommended by the BIDAC and is the amount needed to bring annual revenue to a level that covers annual expenditures. This fee schedule is the same as in program year 2022.

After receiving the BID's annual report, the Council should consider and adopt the attached Resolution of Intent. The Resolution designates December 7, 2022, as the date for a Public Hearing on the levy of the proposed 2023 BID assessment fees and budget. The annual report was available for review at the City Clerk's counter since October 19, 2022.

Once the Public Hearing date is set, a copy of the Resolution and the Annual Report notice will be mailed to all businesses and property owners in the BID and a notice of the public hearing will be published in the local newspaper.

FISCAL IMPACT:

All costs related to Business Improvement District No. 1 come from the BID assessments and not the general fund.

Respectfully prepared and submitted by:



Joseph Torres
Economic Development Manager

Approved by:

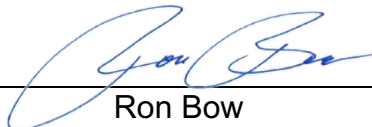

Ron Bow
City Manager

Reviewed by:



Karl H. Berger
City Attorney

ATTACHMENT:

1. Resolution of Intent to Set a Public Hearing
2. 2022 Annual Report

ATTACHMENT 1

Resolution of Intent to Set a Public Hearing

RESOLUTION NO. ____

A RESOLUTION DECLARING THE CITY OF MONTEREY PARK'S INTENT TO LEVY AND COLLECT ASSESSMENTS WITHIN BUSINESS IMPROVEMENT DISTRICT NO. 1 FOR PROGRAM YEAR 2023 AND SETTING A PUBLIC HEARING.

BE IT RESOLVED by the Council of the City of Monterey Park as follows:

SECTION 1: The City Council finds as follows:

- A. Cities are authorized under the Property and Business Improvement District Law of 1994 (Streets & Highways Code §§ 36600, *et seq.*) to establish business improvement districts ("BID") within their jurisdictions for the purpose of funding certain services.
- B. Business Improvement Area No. 1 was established by Ordinance No. 1604 on October 10, 1983 and modified by Ordinance No. 1656 on March 10, 1986.
- C. As required by applicable law, the City prepared an Annual Report for Program Year 2022 for Business Improvement Area No. 1 ("Report") and submitted it to the City Council; and
- D. Based upon the Report, the City Council proposes to levy assessments for Business Improvement Area No. 1 for Program Years 2022 and 2023 as calculated in the Report which is incorporated by reference. A true and correct copy of the Report is available for public review in the City Clerk's office.

SECTION 2: This Resolution constitutes the City Council's notice pursuant to Streets and Highways Code § 36523.5 that it will consider not increasing assessments for the 2022 or 2023 Program Years for Business Improvement Area No. 1 at a meeting and public hearing held on November 16, 2022, at 6:30 p.m. or as soon thereafter as this matter may be heard, City Hall, Council Chambers, 320 West Newmark Avenue, Monterey Park, CA 91754. The assessments will not increase for the 2022 or 2023 Program Years to help BID businesses weather the financial burden brought on by the COVID-19 pandemic. During the public hearing, the City Council will consider all testimonial and documentary evidence for or against the levy of the proposed assessments for Business Improvement Area No. 1 for Program Years 2022 and 2023. Protests may be made orally or in writing. All written documents must be filed with the City Clerk at or before the time fixed for the hearing and contain sufficient documentation to verify business ownership and validate the protest. The form and manner of protests must comply with Streets and Highways Code §§ 36524 and 36525.

SECTION 3: If approved, the assessments would fund specific programs including, without limitation:

- A. Projects for the promotion of business in Monterey Park's Downtown BID area.
- B. Continuing to work with the city to meet the needs of businesses.
- C. Continued janitorial services to the BID area; and
- D. Work with the BID merchants to create a more visitor friendly atmosphere.

SECTION 4: It is proposed that the BID collect an annual assessment of approximately \$75,000 for a period of 12 months. The 2022 and 2023 fees will not increase for the 2023 annual year to help BID businesses recover from the financial burden brought on by the COVID-19 pandemic. The following formula is used to calculate the assessment for each property owner within the BID:

SECTION 5: The City Council intends to adopt the following Fee Schedule for the 2022 (retroactively) and 2023 Program Years:

2023 New BID Fee Schedule

Business Type	Fee	Employee/Seat	Formula
Retail	\$105.17	\$13.52	
Service (Includes Financial)	\$105.17	\$13.52	
Restaurant			
Without ABC	\$105.17	\$ 6.57	(1)
With ABC	\$105.17	\$ 7.87	(2)
Professional (inc. Insurance)	\$105.17	\$13.52	
Theater	\$105.17		
Wholesale	\$105.17		
Manufacturing	\$105.17		
Contractor	\$105.17		
Commercial Rental	\$23.00 + .006574 sq. ft.		(3)
Residential Rental	\$23.00		(4)
Hotel	\$23.00 per unit		
Laundromat	\$105.17		
Street Vendors	\$105.17		

(1) 20 seats or less, no seat assessment fees. Over 20 seats, \$6.57 per seat starting with Seat 21. E.g., for 50 seats, total charge is \$105.17 (base fee) + \$197.10 (30 seats x \$6.57) = \$302.27.

(2) 20 seats or less, no seat assessment fees. Over 20 seats, \$7.87 per seat starting with Seat 21. E.g., for 50 seats, total charge is \$105.17 (base fee) + \$236.10 (30 seats x \$7.87) = \$341.27.

(3) Base fee is \$23.00 per unit. For every additional sq. ft. over 2,000; multiply excess by \$.006574. E.g., 2,500 sq. ft., total charge is \$23.00 + \$3.29 (500 sq. ft. x \$0.006574) = \$26.29 (calculations are rounded up).

(4) If a business owns 1-3 units, there is no charge. If a business owns more than 3 units, it pays \$23.00 per unit in excess of 3 units. E.g., a business owns 5 units and it pays \$23.00 x 2 (5 units – 3 units) = \$46.00.

SECTION 6: Retroactivity. The City Council recognizes that California law including, without limitation, *Melton v. City of San Pablo* (1967) 252 Cal.App.2d 794 and *In re Cindy B. v. Eugene B.* (1987) 192 Cal.App.3d 771, allows legislation to be retroactively applied when the legislative intent for such retroactivity is clear. The City Council intends this Resolution to be retroactively effective on November 1, 2022, as to the 2023 Program Year.

SECTION 7: Supersession. This Resolution supersedes all previous resolutions related to claims and settlements. It will remain effective until superseded by a subsequent resolution.

SECTION 8: Electronic Signatures. This Ordinance may be executed with electronic signatures in accordance with Government Code §16.5. Such electronic signatures will be treated in all respects as having the same effect as an original signature.

SECTION 9: The City Clerk is directed to mail a copy of this Resolution to any person requesting a copy.

SECTION 10: This Resolution is the City Council's final decision and will become effective immediately upon adoption.

PASSED AND ADOPTED this 16th day of November 2022.

Henry Lo
Mayor

ATTEST:

Vincent D. Chang,
City Clerk

APPROVED AS TO FORM:



Karl H. Berger, City Attorney

Staff Report
November 16, 2022

ATTACHMENT 2

2022 Annual Report

CITY OF MONTEREY PARK

BUSINESS IMPROVEMENT DISTRICT NO. 1

2022 ANNUAL REPORT



JANUARY 2022 – DECEMBER 2022

DOWNTOWN Garvey – Garfield



VISION STATEMENT

The Downtown Business Improvement District (BID) No. 1 was established to improve and preserve the business community in the “heart” of the City.

The Downtown area of the City is an important destination point for the business community and residents of Monterey Park. Through continued efforts in organization, beautification, promotion, and revitalization, the City leaders and its business community will work together to preserve and improve the quality of life for future generations.

BOARD MEMBERS

Gene Jeng
Jessy Li

Josephine Louie
Elizabeth Yang

One Vacancy

OVERVIEW

The Business Improvement District Advisory Board (BIDAC) meets quarterly and during special meetings to discuss issues of concern to businesses located within the BID area. Programs addressing cleanliness, promotions, and marketing are all reflected in the budget for the BID. In addition to the issues discussed, the Board also researches and plans innovative ways to promote businesses and maintain the goals and budget outlined in the Annual Report.

HISTORY

The Monterey Park Business Improvement District No. 1 encompasses the area extending along Garvey Avenue from Ramona Avenue to Nicholson Avenue and on Garfield Avenue from south of Newmark Avenue to Emerson Avenue (refer to Exhibit A). The Monterey Park City Council established the BID in 1986 at the request of local businesses in the area and the Downtown Merchants Association (DMA) under the California Streets and Highway Code Section 36500 et seq.

The primary responsibility of the BIDAC is to make recommendations to the City Council on the methods and ways by which revenues derived from the annual assessment are used for the betterment of the BID businesses and the BID area.

The BIDAC comprises five (5) members appointed by the City Council for one year and may serve for up to eight (8) years if reinstated by a Council member. Each City Council member appoints one Committee member. The BIDAC meets quarterly and as needed and hosts an annual meeting of the BID members-at-large at the end of the year, before the following year's assessments.

ACCOMPLISHMENTS

This section of the Annual Report reflects the activities during 2022 to promote or enhance the BID area and its businesses.

Holiday Promotion

Holiday decorations were installed and displayed along Garvey Avenue and the medians to provide a bright seasonal atmosphere for shoppers in the downtown BID.

Janitorial Services

Effective December 1, 2020, Valley Maintenance Corporation, taking over Chrysalis Corporation, was contracted to perform the janitorial services in the BID area four days a week at a significantly reduced rate. In 2022, the City added the cleaning of the Downtown parking lot on Garvey and Garfield to the Valley Maintenance contract with the same significantly reduced rate.

BUDGET

2023 Program Year

The Annual Report contains an estimated budget for the BID for January 1, 2023, to December 31, 2023, and is tied to programs and activities scheduled during the calendar year.

As of September 2022, the City received approximately \$41,841.00 in revenue from the BID for the calendar year 2022. Exhibit B reflects the estimated expenditures for the calendar year 2022. Exhibit C shows the actual expenditures as of September 2022, and Exhibit D reflects the BID's Estimated Annual Program Budget for the program year 2023.

GOALS for 2023

This section of the Annual Report shows the programs or activities intended for 2023.

- Continue to work with the Downtown BID businesses on ways they can assist in keeping the area attractive.
- Continue janitorial services for the BID area.
- Install holiday decorations along Garvey Avenue, remove them, and place them in storage.
- Work with the City to provide resources, workshops, and other business assistance activities for businesses in the BID area.
- Support City projects that benefit the BID area, such as discussions on the need for a parking structure in the BID, signage, and maintenance; identify ways to promote businesses in the BID.

Exhibits:

- A: BID Area Map
- B: 2022 Estimated Expenditures
- C: 2022 Actual Expenditures
- D: 2023 Estimated Budget
- E: 2023 Fee Schedule

EXHIBIT A

BUSINESS IMPROVEMENT DISTRICT NO. 1 MAP



EXHIBIT B

Business Improvement District No. 1

2022 Estimated Expenditures

Budget Item	Description	2022 Est. Expenditures
Administration	Postage	\$ 600.00
	Business Cards	\$225.00
	Translation Services	\$1,200.00
	Office Supplies	\$300.00
Street Banners	20 Large Banners 30" x 96"	\$3,380.00
	34 Small Banners	\$3,740.00
	1 Across the Street Banner	\$1,400.00
	Single & Double Brackets	\$6,912.00
Holiday Decoration	Holiday light bulb replacement	\$500.00
	Edison	\$625.00
	Holiday light storage & installation	\$5,577.00
Trash Receptacles	Liners & lids	\$200.00
Landscaping	Additional planting supplies	\$1,000.00
Custodial Contract	Maintenance of the BID area	\$ 21,840.00
	Pressure Washing	\$7,360
	TOTAL EST. EXPENDITURES:	\$54,859.00

EXHIBIT C

Business Improvement District No. 1

2022 Actual Expenditures as of September 2022

Beginning Fund Reserves Balance: \$136,151.12

Budget Item	Description	2023 Estimated Budget
Administration	Postage	\$613.21
	Business Cards	\$0.00
	Translation Services	\$0.00
	Office Supplies	\$0.00
Holiday Decoration	Holiday light bulb	\$0.00
	Edison Poles Adapters	\$1,050.18
	Holiday light storage & installation	\$9,425.00
Trash Receptacles	Additional liners & lids	\$0.00
Landscaping	Additional planting supplies	\$0.00
Custodial Contract	Maintenance of the BID area	\$23,680.00
	TOTAL EXPENDITURES:	\$34,768.39
Revenue as of 09/2022		\$41,841.23
Reserves as of 09/2022		\$187,010.53

EXHIBIT D

Business Improvement District No. 1

2023 Estimated Budget

Budget Item	Description	2023 Estimated Budget
Administration	Postage	\$1,500.00
	Business Cards	\$150.00
	Translation Services	\$1,200.00
	Office Supplies	\$300.00
BID Promotion	Incentives, marketing, & promotions	\$5,500.00
Holiday Decoration	Holiday light bulb replacement	\$500.00
	Edison	\$600.00
	Holiday light storage & installation	\$5,577.00
Trash Receptacles	Additional liners & lids	\$200.00
Landscaping	Additional planting supplies	\$1,000.00
Custodial Contract	Maintenance of the BID area	\$21,840.00
	Pressure Washing	\$7,360.00
	Downtown Parking Lot Cleaning	\$15,120.00
	TOTAL:	\$60,847.00

EXHIBIT E

2023 BID Fee Schedule (same as last year)

Business Type	Fee	Employee/Seat	Formula
Retail	\$105.17	\$13.52	
Service (Includes Financial)	\$105.17	\$13.52	
Restaurant			
Without ABC	\$105.17	\$ 6.57	(1)
With ABC	\$105.17	\$ 7.87	(2)
Professional (inc. Insurance)	\$105.17	\$13.52	
Theater	\$105.17		
Wholesale	\$105.17		
Manufacturing	\$105.17		
Contractor	\$105.17		
Commercial Rental	\$23.00 + .006574 sq. ft.		(3)
Residential Rental	\$23.00		(4)
Hotel	\$23.00 per unit		
Laundromat	\$105.17		

- (1) 20 seats or less, no seat assessment fees. Over 20 seats, \$6.57 per seat starting with Seat 21. Eg. For 50 seats, total charge is \$105.17 (base fee) + \$197.10 (30 seats x \$6.57) = \$302.27.
- (2) 20 seats or less, no seat assessment fees. Over 20 seats, \$7.87 per seat starting with Seat 21. Eg. For 50 seats, total charge is \$105.17 (base fee) + \$236.10 (30 seats x \$7.87) = \$341.27.
- (3) Base fee is \$23.00 per unit. For every additional sq. ft. over 2,000; multiply excess by \$.006574. Eg. 2,500 sq. ft., total charge is \$23.00 + \$3.29 (500 sq. ft. x \$.006574) = \$26.29 (calculations are rounded up)
- (4) If you own 1-3 units, there is no charge. If you own more than 3 units, you pay \$23.00 per unit more than 3 units. Eg. You own 5 units. You pay \$23.00 x 2 (5 units – 3 units) = \$56.00



City Council Staff Report

DATE: November 16, 2022

AGENDA ITEM NO: Consent Calendar - 3F

TO: The Honorable Mayor and City Council
FROM: Shawn Igoe, Director of Public Works
SUBJECT: Title VI – Civil Rights Program Update For Spirit Bus

RECOMMENDATION:

It is recommended that the City Council consider:

1. Approving the Title VI of the Civil Rights Act of 1964 (Title VI) Program Update;
2. Authorizing the City Manager or designee to submit the Title VI Program Update to the Los Angeles County Metro Office of Civil Rights and Federal Transit Administration (FTA); and
3. Taking such additional, related, action that may be desirable.

EXECUTIVE SUMMARY:

The Title VI of the Civil Rights Act of 1964 (Title VI) prohibits discrimination on the basis of race, color, and national origin in programs or activities that receive federal funding. The Federal Transportation Administration (FTA) requires agencies that receive their grant funds to demonstrate compliance with Title VI by submitting a Title VI Program Update every three years. The City Council last approved the Title VI Program in 2019. Staff recommends City Council approve the City's Title VI program update for continued compliance with FTA requirements as a sub-recipient of Los Angeles County Metro for pass-through funds. Failure to submit a Title VI Program Update could make the City ineligible for federal funding and result in loss of federal financial assistance.

BACKGROUND:

As a recipient of federal funding, the City is required to comply with Title VI civil rights regulations.

Title VI of the Civil Rights Act of 1964 states the following:

"No person in the United States shall, on the grounds of race, color, or national origin, be excluded from participation in, be denied the benefits of, or be subjected to discrimination under any program or activity receiving Federal financial assistance."

The Title VI Program Update document consists of a plan and supporting documentation that provides evidence of the equitable distribution of services; promotion of full and fair participation in public transportation decision-making without regard to race, color, or national origin, and meaningful access to transit-related programs and activities by

persons with limited English proficiency. FTA reviews and approves the Title VI Program Update or may request additional information. Failure to submit a Title VI Program Update or have a Title VI Program Update approved by the FTA could result in the loss of Federal funding.

The Title VI Program Update report must incorporate the following requirements set forth in the FTA Circular 4702.1B:

1. A notice to the public that indicates the City is compliant with Title VI, and informs members of the public of the protections against discrimination afforded to them by Title VI;
2. Complaint procedures and complaint form(s) made available to members of the public to file a Title VI discrimination complaint;
3. A list of all transit-related complaints, investigations, or lawsuits filed within the last program cycle;
4. A Public Participation Plan;
5. A Language Assistance Plan for persons with limited English Proficiency;
6. A racial breakdown of transit-related planning and advisory committees;
7. Assistance to and monitoring of sub-recipients;
8. Equity evaluations relating to the site and location of facilities;
9. Service standards and system-wide service policies;
10. Collection and reporting of demographic data; and
11. Monitoring of transit service

City Council must approve the proposed Title VI Program Update report prior to submission to Los Angeles County Metro Office of Civil Rights and the FTA. A copy of the meeting minutes will be submitted to the FTA as evidence of its approval.

FISCAL IMPACT:

The City has previously received FTA grant funds as a subrecipient of Los Angeles County Metro for the replacement of transit buses, and bus stop improvements including funding for the construction of the Transit Center at East Los Angeles Community College. These assets are still in service, and the City must continue to comply with FTA funding requirements, by adopting the Title VI Program update every three years.

Respectfully submitted by:

Prepared by:



Shawn Igoe
Director of Public Works



Xochitl Tipan
Principal Management Analyst

Approved by:

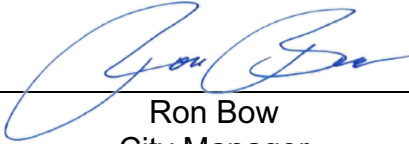

Ron Bow
City Manager

Reviewed by:

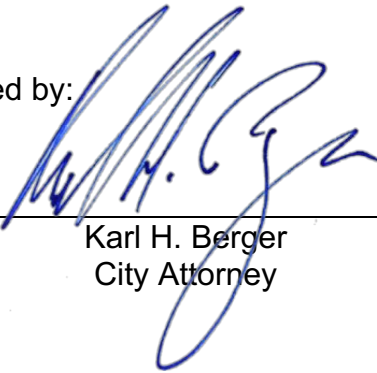

Karl H. Berger
City Attorney

ATTACHMENT(S):

1. Title VI Program Update - 2022

ATTACHMENT 1

Title VI Program Update

CITY OF MONTEREY PARK

320 West Newmark Avenue • Monterey Park • California 91754-2896
www.ci.monterey-park.ca.us



City Council
Peter Chan
Hans Liang
Henry Lo
Yvonne Yiu

City Clerk
Vincent D. Chang

City Treasurer
Joseph Leon

CITY OF MONTEREY PARK



TITLE VI PROGRAM UPDATE
EFFECTIVE NOVEMBER 16, 2022

TABLE OF CONTENTS

	Page
I. Introduction	
1. Annual Title VI Certification.....	2
2. Notification of Beneficiaries	2
3. Title VI Complaint Procedure	2
4. Recording Title VI Investigations, Complaints, and Lawsuits.....	3
5. Membership of Non-Elected Committees and Councils	4
6. City Council Resolution Approving Updated Title VI Program.....	5
II. INCLUSIVE PUBLIC PARTICIPATION	
1. Public Outreach Efforts	5
2. Incorporating Environmental Justice into Planning.....	6
3. Outreach Efforts.....	6
III. LANGUAGE ASSISTANCE PLAN	
1. Improving Access for People with Limited English Proficiency (LEP).....	7
2. Four Factor Analysis	7
3. Language Assistance Measures	9
4. Training Staff	10
5. Providing Notice to LEP Persons.....	10
6. Monitoring and Updating the LEP Plan	10
IV. SERVICE POLICIES AND STANDARDS	
1. Vehicle Assignments/Age of Vehicles.....	10
2. Vehicle Load	11
3. Vehicle Headways (Frequencies).....	11
4. On-Time Performance	11
5. Transit Access.....	11
6. Distribution of Transit Amenities	12
7. Monitoring Service Standards	12
V. OTHER PROGRAM SPECIFIC REQUIREMENTS.....	12
APPENDICES	
A. Title VI Notification	
B. Complaint Procedure	
C. Complaint Form	
D. Administrative Policy No. 10-35	

I. INTRODUCTION

1. Annual Title VI Certifications and Assurances In accordance with 49 CFR Section 21.7(a).

The City of Monterey Park (City) will submit an annual Title VI assurance and a triennial Title VI Program Update to the Los Angeles County Metropolitan Transportation Authority (MTA). MTA is the City's pass-through agent for Federal Transit Administration (FTA) grant funds that the City is awarded to replace transit vehicles and to make improvements at bus stops.

The City operates a fixed-route service - Spirit Bus - and a demand responsive service - Dial-A-Ride. Both services operate generally within City limits. The City contracts with a private company to operate the Spirit Bus; the service is available to the general public for a cash fare of 25 cents for Routes 1 to 4 and 50 cents for Route 5 and the Metrolink feeder service. Dial-A-Ride is operated in-house and is restricted to senior residents who are 55 years and older and individuals with disabilities. Dial-A-Ride is a free service.

2. Notification of Beneficiaries of Protection under Title VI

In compliance with 49 CFR Section 21.9 (d), the City provides information to the public regarding its Title VI obligations and apprises members of the public of the protection against discrimination afforded to them by Title VI. This statement of nondiscrimination on the basis of race, color, and national origin is available on the City's website and on notices posted in City-owned service vehicles and City Hall.

The notice also includes contact information for requesting details on the City's Title VI obligations and the complaint procedure. The notice is in English, Chinese and Spanish.

3. Title VI Complaint Procedure

In order to comply with 49 CFR Section 21.9 (b), the City will follow a complaint procedure in the event that any person believes that he or she, individually, or as a member of any specific class of persons, has been excluded from participation in, been denied the benefits of, or been subjected to discrimination on the basis of race, color, or national origin with regard to:

- the availability and equitable distribution of transit services and benefits;
- the level and quality of transit services that are sufficient to provide equal access and mobility for all persons;
- the opportunity to participate in the transit planning and decision making processes; and
- the right to fair decisions on the location of transit services and facilities.

Procedure

The complaint will be made in writing to the Director of Public Works and will include all information relevant to a determination of discrimination. A complaint must be filed within six

(6) months after the alleged discrimination. In cases where the complainant is unable or incapable of providing a written statement, City staff will assist the person in converting verbal complaints to writing. The complainant or his/her representative must sign all complaints.

After reviewing the complaint, which may include interviewing all appropriate personnel and the complainant and review of City policies and service standards, the Director of Public Works will make a determination. If it is found that discrimination did not occur, the complainant will be notified in writing and the procedure will be terminated. Notification will occur within ten (10) days of the original submission of the complaint. At that time, the complainant will be advised of his or her right to challenge the decision of the Director of Public Works by submitting a written request for a hearing before the City Manager within five (5) days of the receipt of the determination.

If, after the Director of Public Works' review of the complaint, it is found that discrimination may have occurred, a formal hearing will be held before the City Manager. The claimant will be notified of this determination within ten (10) days of the submission of the complaint. The hearing will occur within five (5) days and will be attended by the Director of Public Works, the City Manager, the complainant and the appropriate personnel. Following the hearing, the City Manager will make a final determination. The complainant will be notified of this determination in writing within ten (10) days of the hearing. If justified, appropriate remedial action will be taken.

If the complainant is not satisfied with the City's decision, the Director of Public Works will advise him/her of their right to submit their complaint to the FTA for further investigation.

Complaint procedure and forms are available in English, Chinese and Spanish on the City's website at <http://www.montereypark.ca.gov/436/Public-Works>. Complaint information is also available at City Hall upon request.

4. Recording Title VI Investigations, Complaints, and Lawsuits

In order to comply with 49 CFR Section 21.9 (b) the City maintains a list of any active investigations, lawsuits, or complaints naming the City and/or its subcontractor(s) that allege discrimination on the basis of race, color, or national origin.

To date there has been no complaint.

Title VI Investigations, Complaints and Lawsuits Log						
Number	Date of Filing	Type of Complaint	Summary of Complaint	Status	Determination	Remedial Action

5. Membership of Non-Elected Committees and Councils

The City of Monterey Park was incorporated on May 29, 1916. It is a general law city as defined by the California Government Code. It operates under the Council-Manager form of government. The City Council is elected at large for four-year, overlapping terms.

Three commissions may make decisions that affect the City's transit service: Planning Commission, Traffic Commission, and Environmental Commission. The Planning Commission is a legislative body consisting of five members who advise the Council on policies and legislation relating to the regulation of growth, development, and environmental conditions affecting the City. The Commission investigates and makes recommendations on zone changes, specific plan revisions, subdivision maps, and decides on zone variances and conditional use permits, subject to appeal to the City Council.

The Traffic Commission reviews traffic issues and recommends any needed changes. Issues range from traffic safety matters to parking restrictions that may be the result of a citizen's request or a staff recommendation. The Commission also makes recommendations to the City Council for installation of stop signs and amendments to the Monterey Park Municipal Code (MPMC) for traffic related items that may ease traffic congestion and help facilitate transportation throughout the City.

The Environmental Commission promotes the preservation of natural resources and the sustainability of the community. The Commission's responsibilities include serving in advisory capacity to the City Council on related issues, assisting in issues that are deemed necessary for the environmental integrity of the city, and advocating and promoting programs to increase awareness of the environment.

While the City Council members are elected officials, Commissioners are appointed. Each of the five City Council members appoints a member to the Planning Commission, a member to the Traffic Commission and a member to the Environmental Commission. There are a total of five members at each commission. The make-up of the Commissions has historically been representative of the diverse community.

The City Council selects members to sit on the Planning Commission based on their knowledge of zone changes, specific plan revisions, subdivision maps, and zone variances and conditional use permits. The Traffic Commissioners should be familiar with issues that range from traffic safety matters to parking restrictions.

Criteria for the selection of members of the Environmental Commission include knowledge of environmental issues to include water and air quality, natural resources and sustainability.

Body	Caucasian	Latino	African American	Asian American	Native American
Planning Commission		1		4	
Traffic Commission	1	1		2	
Environmental Commission				2	

6. City Council Resolution Approving Updated Title VI Program

At the November 16, 2022 City Council meeting, the Monterey Park City Council approved this updated Title VI Program.

II. INCLUSIVE PUBLIC PARTICIPATION

The City of Monterey Park’s public participation strategy includes a variety of communication mechanisms to ensure that *all constituents* have an opportunity to participate in service development and changes.

1. Public Outreach Efforts

Public participation will be engaged in all areas related to the Spirit Bus service including, but not limited to, service change, publicity and promotions, temporary changes (e.g., detours, special service), and fare media.

Depending on the type of service change that is contemplated, a variety of means are employed to encourage public participation. The measures taken are targeted to overcome linguistic, institutional, cultural, economic, historical, or other barriers that may prevent minority and low-income populations, persons with disabilities and persons with limited English proficiency from effectively participating in the decision making process.

Any proposal for service change is advertised in the City newsletter, *Cascades*, which is distributed to every household and business in the City. The *Cascades* is translated into both Spanish and Chinese languages. The *Cascades* is also available on the City's website. Further outreach is a press release that includes mainstream newspapers, Chinese newspapers, Spanish newspapers and all elected officials who represent constituents who live within the City of Monterey Park. The potential for a change/enhancement to service/fares is a result of carefully evaluated data by appropriate staff.

The proposal will be placed on the agenda for the Planning and Traffic Commissions for their review and action. Once public feedback has been collected, the proposal will proceed to the public hearing process. The City Council will make their decision based on public comments, Commission recommendations, and staff evaluation.

Public meetings will be held in facilities that are in compliance with American with Disabilities Act (ADA) standards. Most meetings will be scheduled at the City Hall. However, if funding allows for multiple meetings, geographically-diverse locations will be selected for venues. Meetings are scheduled in the early evenings or weekends and may be conducted remotely to accommodate working schedules.

The outreach will target low income individuals who may have limited access to transportation and the news media. Flyers and notices will be posted at City Hall, the Langley Senior Center and the Public Library where free or discounted services are made available. The City's monthly newsletter is mailed free of charge to every household.

Also, if financial condition permits, translators will be provided at the meetings. At a minimum, Chinese and Spanish translations will be provided. Efforts will be made to provide Vietnamese translators.

2. Incorporating Environmental Justice into Outreach and Planning

Environmental Justice Practices are incorporated into all City planning and outreach efforts. Specific steps will be followed when conducting a transit service change, planning study or construction project:

- Compilation of population characteristics and identification of locations with populations of concern for environmental justice;
- Conducting public outreach;
- Identifying adverse effects on populations of concern; and,
- Evaluating the project's overall effects.

3. Outreach Efforts

The city's fixed-route transit service was suspended from April 2020 through July 2022. During this time, the City's outreach efforts related to transit consisted of periodic updates on program suspension and distribution of service updates from Metro bus line during the pandemic. Metro provided brochures on service updates which the City made available to the public. The updates that were distributed included Spanish and Chinese translations. The City also included Metro's updated information and links regarding its NextGen Bus Plan on its website.

Additionally, the City promoted public participation for its evaluation of its fixed-route transit program. In 2022, the City held three community engagement sessions and distributed a community and student survey. Outreach was conducted through social media, City website, and additional distribution through local schools. Additionally, flyers were posted at various City facilities and buses. The public was also encouraged to participate and voice their comments regarding transit services and areas of improvement at public meetings.

III. LANGUAGE ASSISTANCE PLAN

1. Improving Access for People with Limited English Proficiency (LEP)

Recognizing the remarkable diversity of its constituents, the City Council adopted the Multi-lingual City Services policy to better serve the community. The Administrative Policy was the product of a multi-lingual task force that was formed as a sub-committee of the Community Relations Committee. The policy is available in Appendix D.

The City’s Language Assistance Plan incorporates all reasonable steps to ensure access to transportation services for LEP individuals.

The plan has the following key elements:

- Identification of LEP individuals who need language assistance in the City using the four factor analysis;
- Determination of the appropriate language assistance measures;
- Training employees on LEP policies and procedures;
- Notification to LEP persons of the language services offered by the City; and
- Procedures to monitor and update the Language Assistance Plan.

2. Four Factor Analysis

The *Four Factor Analysis* considers:

1. The number or proportion of LEP persons eligible to be served or likely to be served by the Spirit Bus System;
2. The frequency with which LEP persons come into contact with the Spirit Bus service;
3. The nature and importance of the Spirit Bus service in people’s lives; and,
4. The resources available to the City for LEP outreach.

1) Number/Proportion of LEP Persons

CENSUS DATA - The determination of the number of LEP persons is based on the U.S. Census Bureau “American Fact Finder” 2020 Estimated data. The table below identifies "language spoken at home by ability to speak English for the population 5 years and over" in the City of Monterey Park.

American Fact Finder 2020				
Speak only English	15,053	26%		
Other Language Spoken at Home	42,749	74%		
Speak English "very well"			19,437	45.5%
Speak English less than "very well"			23,312	54.5%
Total	57,802	100.00%	42,749	100.00%

A breakdown on the language spoken at home is provided in the following table:

Language Spoken		Speak English "very well"	Speak English less than "very well"
Speak only English	15,053		
Spanish	10,434	8,180	
			2,254
Asian and Pacific Island Languages	31,165	10,286	
			20,879
Indo-European languages	924	766	
			158
Other languages:	226	205	
			21
TOTAL	57,802	19,437	23,312

Based on the data, the majority of LEP persons are identified as either speaking Spanish or an Asian/Pacific Island language. While approximately 74% speak a language other than English at home, about 54.5% speak it less than very well. The City currently has staff that can provide verbal and written translation assistance in multiple languages including Chinese, Vietnamese, and Spanish. The City will continue to monitor the number of constituents who require assistance with translation, but at this time the City's policy is to require written translation of all vital documents in Spanish and Chinese only.

Currently, the reading level of LEP individuals is unknown. The City takes pride in its Literacy for All of Monterey Park (LAMP) that has been a leader in adult and family literacy programs since 1984. The learner-centered literacy services are provided at no cost. Trained volunteers in one-to-one, small group, and classroom settings provide tutoring and instruction. LAMP provides assistance through volunteer English-as-a-Second Language (ESL) instructors who have some teaching experience and conduct basic English instruction in all levels of ESL.

2) Frequency with which LEP persons come into contact with the Spirit Bus

The local bus service is contracted out to a private company that operates and maintains the City vehicles. The private firm is also responsible for setting up a customer information phone line for the public to call for information.

The existing contract will terminate on June 30, 2023. The City works with the contractor to address issues regarding communication with LEP persons.

City staff currently does not track interaction with LEP persons either at the public counter or on the phone due to the rarity of these incidents (e.g., < 10 times per year).

3) *The Nature and Importance of the Spirit Bus*

The Spirit Bus is a critical public service to the community. Nearly 40 percent of the City's population is 55-year-old and older, and 23 percent are over 65 years old. The seniors depend on the Spirit Bus for transportation for their basic needs: access to food, doctor's appointments and recreation. Through complaints that City receives on a regular basis, staff becomes aware of bus riders' concerns and needs. Most recently, the City released a community survey to further understand the public's mobility needs.

Because of the essential nature of the services and the importance of these programs in the lives of the City's residents, there is a need to ensure that language is not a barrier to access. Using information that was gathered from the demographic analysis in August 2013, employee experiences, community partner observations and customer comments, the City will provide the outreach necessary to ensure access is not compromised as a result of a language barrier.

City staff's interaction with LEP individuals is currently not quantitatively tracked. Per the City's Administrative Policy, the City Manager meets with Department Directors on a regular basis to discuss the multi-lingual program and exchange solutions and share resources. City Manager and Director Meetings are held weekly.

4) *The Resources Available to LEP Outreach*

The City's contract with a publisher to produce its monthly newsletter - *Cascades* - requires the publication to translate "*Featured Stories*" into both Spanish and Chinese. The publisher can also provide translation services for other material as needed.

In addition to the Title VI documentation such as the complaint form, procedures and Civil Rights notice, documents that are translated include public suggestion/complaint forms and Dial-A-Ride registration and policy/guidelines. The Spirit Bus schedule and related articles that are published in the *Cascades* are translated into Spanish and Chinese.

One of the criteria in the hiring of employees who are responsible for interacting directly with the public is proficient Spanish and Chinese language skills. A large segment of City staff speaks and understands Spanish or Chinese language, or both. Multi-lingual employees receive incentive pay to translate not only for their own department but also for other departments as necessary.

3. Language Assistance Measures

The Spirit Bus contractor will be required to submit their language assistance program that will be reviewed and approved by the Director of Public Works. The program will address how drivers and customer service representatives respond to passengers who are not proficient in English. The contractor has been informed of the Title VI requirements and has posted the notice on all service vehicles.

4. Training Staff

The Spirit Bus contract will require that drivers and customer service representative receive ongoing training in language assistance. The contractor will be required to train all the new employees on the language assistance program.

City staff will receive updated training on the multi-lingual policy that includes providing language identification cards at public counters. New employees will be briefed on the language assistance program as part of their new hire orientation. Staff members who routinely interact with the public will be provided with updated lists of multi-lingual City employees, volunteer translators and interpreters.

5. Providing Notice to LEP Persons

LEP persons are notified of the language services available by notices posted on-board transit vehicles, City Hall, the City website, and at the information kiosk at the Transit Center at East Los Angeles College. Notices will be available in both Spanish and Chinese.

Vital documents are translated into LEP identified languages. The City's Multilingual Service Plan is attached in Appendix D.

6. Monitoring and Updating the LEP Plan

The City's multi-lingual policy was adopted on December 18, 2003 and requires annual review and updates to ensure that measures are relevant and effective.

Every three years, the City will review census updates and other data to determine any changes in the proportion of LEP groups. Special attention will be paid to the Vietnamese community.

The City will review the contractor's monthly complaint logs and identify any trends in language assistance needs. The City will also review the contractor's driver logs of the frequency of encounters with LEP individuals.

Assessment of these reviews will be used to update the LEP Plan.

IV. SERVICE POLICIES AND STANDARDS

The City has the following policies and standards as guidelines to assure the equitable distribution of services and the accessibility of the fixed-route services:

1. Vehicle Assignments/Age of Vehicles

The Spirit Bus fleet includes 9 vehicles: (3) 2018 Arboc Spirit of Mobility, (1) 2015 Arboc low floor cutaway, (3) 2013 El Dorado BRT mid-sized buses, , (1) 2011 El Dorado AeroElite cutaway, and (1)

contractor-owned cutaway spare. The City-owned cutaway vehicles are typically assigned to lower ridership routes and the mid-size buses are rotated to the four community routes. No preference is given to any particular route for the assignment of a newer bus.

The City maintains a transit replacement schedule for the Spirit fleet. Three buses are scheduled for replacement in 2023.

2. Vehicle Load

Vehicle load is expressed as the ratio of passengers to the total number of seats on a vehicle. The average daily ridership of the Spirit Bus has dropped from 15.82 passengers per revenue vehicle hour in FY 2017 to 12.36 in FY 2019. The bus service was suspended from April 2020 through July 2022, due to the Covid19 pandemic. Full-year data for ridership post-pandemic will be available at the end of FY23. Larger mid-sized buses are operated on these routes and can seat 23 passengers. When school lets out, the load on the buses can exceed 1.0 but at all other times there are no standees on the buses. The buses seat 23 passengers with standing room for up to 40 adults. Vehicle load is 1.5.

Vehicle load data are currently not tracked on the Spirit Bus. The contractor is instructed to alert the City of any problems experienced.

3. Vehicle Headways (Frequencies)

Vehicle headway is the amount of time between two buses traveling in the same direction on a given route. Each of the four community routes - Routes 1, 2, 3 and 4 – typically operates every 40 minutes. The business/employee route - Route 5 - and the Metrolink shuttle operate every 30 minutes. Service times can vary during times of modified or limited service.

4. On-Time Performance

On-time performance is a measure of runs completed as scheduled. The Spirit Bus contract holds the contractor accountable to operating 95% of all trips on-time on any monthly reporting period. On-time is defined as service trip departing less than 10 minutes in advance of scheduled time point and 15 minutes following the scheduled time point.

The contractor is liable for liquated damages for not meeting the standard. All routes must abide by the same performance standards.

5. Transit Access

The Spirit Bus system was designed to provide access to all public facilities including schools, parks and the Civic Center as well as the major commercial corridors. Bus stops locations are at attraction centers such as schools, shopping and business centers, and parks.

Generally, Spirit bus service is accessible within half mile of any location within the City boundary. However, the steep terrain at certain locations can make access a challenge especially for the elderly.

Minority groups are well distributed within the City.

6. Distribution of Transit Amenities

Transit amenities include shelters, benches and trash containers. The site selection for bus shelters and seating are based on ridership and physical limitations of the bus stop. Nearly all shelters are located along commercial corridors. The maintenance of all shelters and bus stop signs is maintained by City staff. Inspections of these amenities are done on a periodic basis. Replacement and addition of transit amenities are considered based on available budget resources.

7. Monitoring Service Standards

Monitoring of the service standards is integral to operational planning. Vehicle replacement is included in capital planning that is reviewed annually when preparing and adopting the fiscal budget. The vehicle load is reviewed when evaluating monthly ridership. Headways relate to the ability to maintain the schedule while on-time performance is monitored daily. Service accessibility and transit amenities are part of the on-going annual planning activities.

V. OTHER PROGRAM SPECIFIC REQUIREMENTS

Equity Analysis for Facility

The City has completed the construction of a Transit Center at East Los Angeles College (ELAC). The facility was previously an ELAC property that was exchanged with the City for 8-feet of right-of-way on Collegian Avenue where the Transit Center is located. The removal of the right-of-way lane eliminated on-street parking on the west side of Collegian Avenue. The college utilized the 8 feet right of way to expand their Performing and Fine Arts Complex.

The college property that was exchanged to the City for the Transit Center was previously an open parking lot for college instructors and staff. A 5-story parking structure has since been constructed adjacent to the Transit Center to provide additional parking that was needed for the college's expansion.

The construction of the transit center did not require acquisition of land and did not displace people from homes or places of business and therefore an equity analysis was not conduct

Demographic Service Profile

The City operates six vehicles in peak fixed-route service; therefore, a demographic profile was not prepared for this plan.

Title VI of the Civil Rights Act of 1964

The City of Monterey Park is the recipient of federal transportation funding and operates its programs without regard to race, color and national origin in accordance with Title VI of the Civil Rights Act. Any person who believes that he or she has been aggrieved by any unlawful discriminatory practice under Title VI may file a complaint with the City of Monterey Park. Complainant may file a complaint pertaining to race, color or national origin with the Federal Transit Administration (FTA), Office of Civil Rights, Attention: Complaint Team, East Building, 5th Fl – TCR, 1200 New Jersey Ave., SE, Washington, DC 20590.

For more information on the City of Monterey Park's civil rights program, and the obligations and procedures to file a complaint, contact (626) 307-1320, email PublicWorks@montereypark.ca.gov or visit the Public Works Department at 320 W. Newmark Ave., Monterey Park, CA 91754.

If information is needed in another language, contact (626) 307-1320.

1964 公民權利法第 6 項

蒙特利公園市是聯邦運輸資金的接收者，也是負責該項目運作的操作者。根據公民權利法第 6 項，聯邦運輸資金的接收及操作者 (蒙特利公園市) 不會對任何種族，膚色及民族血統存在任何歧視因素。若任何人士認為他/她在此法規下受到任何不平等歧視時，可向蒙特利公園市政府提出訴訟申請。投訴人亦可以到聯邦運輸管理局提出訴訟，地址: **Federal Transit Administration (FTA), Office of Civil Rights, Attention: Complaint Team, East Building, 5th Fl – TCR, 1200 New Jersey Ave., SE, Washington, DC 20590.**

若需更多有關蒙特利公園市公民權利法資訊內容，義務和程序來提出訴訟申請，請聯繫(626)307-1320，或電郵 PublicWorks@montereypark.ca.gov，或親臨公共工程部門查詢詳情，地址：320 W. Newmark Ave., Monterey Park, CA 91754。

若需其他語言資料協助，請電(626)307-1320。

Título VI de la Ley de Derechos Civiles de 1964

La Ciudad de Monterey Park recibe fondos federales para el transporte urbano y opera sus programas sin distinción de raza, color y origen nacional en conformidad con las disposiciones del Título VI de la ley de derechos civiles. Cualquier persona que cree que él o ella han sido víctima de la práctica discriminatoria ilegal bajo el Título VI puede presentar su queja con la Ciudad de Monterey Park. Demandante puede presentar una denuncia relacionada a la discriminación por raza, color u origen nacional con la Federal Transit Administration (FTA), Office of Civil Rights, Attention: Complaint Team, East Building, 5th Fl – TCR, 1200 New Jersey Ave., SE, Washington, DC 20590.

Para obtener más información sobre los derechos civiles del programa de la Ciudad de Monterey Park y las obligaciones y procedimientos para presentar una queja, llame al (626) 307-1320, correo electrónico PublicWorks@montereypark.ca.gov o visiten el Departamento de Obras Públicas en 320 W. Newmark Ave., Monterey Park, CA 91754.

Si necesita esta información en otro idioma, llame al (626) 307-1320.

Title VI Discrimination Complaint Procedure

The complaint will be made in writing to the Director of Public Works and will include all information relevant to a determination of discrimination. A complaint must be filed within six (6) months after the alleged discrimination. In cases where the complainant is unable or incapable of providing a written statement, City staff will assist the person in converting verbal complaints to writing. The complainant or his/her representative must sign all complaints.

After reviewing the complaint, which may include interviewing all appropriate personnel and the complainant and review of City policies and service standards, the Director of Public Works will make a determination. If it is found that discrimination did not occur, the complainant will be notified in writing and the procedure will be terminated. Notification will occur within ten (10) days of the original submission of the complaint. At that time, the complainant will be advised of his or her right to challenge the decision of the Director of Public Works by submitting a written request for a hearing before the City Manager within five (5) days of the receipt of the determination.

If, after the Director of Public Works' review of the complaint, it is found that discrimination may have occurred, a formal hearing will be held before the City Manager. The claimant will be notified of this determination within ten (10) days of the submission of the complaint. The hearing will occur within five (5) days and will be attended by the Director of Public Works, the City Manager, the complainant and the appropriate personnel. Following the hearing, the City Manager will make a final determination. The complainant will be notified of this determination in writing within ten (10) days of the hearing. If justified, appropriate remedial action will be taken.

If the complainant is not satisfied with the City's decision, the Director of Public Works will advise him/her of their right to submit their complaint to the Federal Transit Administration (FTA) for further investigation.

If the information is needed in another language, please call (626) 307-1320.

Appendix C

Title VI Discrimination Complaint Form

Please complete and mail to:

Director of Public Works, City of Monterey Park, 320 W. Newmark Ave., Monterey Park, CA 91754

Name: _____

Street Address and Apt./Unit #: _____

City or Town, State and ZIP Code: _____

Telephone: _____

Email: _____

Discrimination due to: Race Color National Origin Sex Age Disability

Please provide date(s) and location of the alleged discrimination, the name(s) of the individual(s) who allegedly discriminated against you including their titles (if known). _____

Please provide the names, addresses and telephone numbers of any witnesses. _____

Explain as briefly and as clearly as possible what happened, how you feel that you were discriminated against and who was involved. Please include how other persons were treated differently from you. _____

Signature

Date

Include additional sheets of paper and other supporting document as necessary.

標題VI歧視投訴程序

投訴需要以書面方式遞交予市政府公共工程總監，必須包括相關的所有資料及文件以便測定歧視問題。涉嫌歧視的投訴必須於事件發生後六個月內提交。如投訴人無法提供一份書面聲明，市政府工作人員將協助該投訴人作出口頭陳述的書面投訴。投訴人或他/她的代表將簽署所有投訴書。

市政府審查過程將包括與所有相關的市政府人員面談以及審查市政府的政策和服務標準，市政府公共工程總監將於投訴和審查面談後確定歧視投訴是否成立。倘若發現歧視行為並不存在，投訴人將於提交申訴後十天內收到書面通知，審查程序亦將被終止。投訴人在收到書面通知後亦有權利於五天內提交書面請求提出異議並要求於聽證會上向城市管理處處長提出申訴。

倘若市政府公共工程總監審查投訴後，發現歧視可能發生，市政府公共工程總監審將會召開正式聽證會並由城市管理員主持。申請人會於提交申訴後十天收到舉行聽證會決定通知。聽證會將於五日內舉行，出席人士包括市政府公共工程總監、城市管理處處長、投訴人及相關的市政府人員。在聽證會上，城市管理處處長將做出最終決定。投訴人將於聽證會後十天內收到書面形式的決定通知。倘若發現歧視確實存在，市政府將採取合理適當的補救行動。

如果投訴人不滿意城市的決定，市政府會建議他/她的行駛權利並向聯邦運輸管理局提交投訴作進一步調查。

如果需要另一種語言的歧視投訴程序信息，請致電（626）307-1320。

標題VI歧視投訴程序表格

請填寫並郵寄至：

Director of Public Works
City of Monterey Park
320 W. Newmark Ave., Monterey Park, CA 91754

姓名: _____

街道地址和公寓/單位#: _____

市或鎮，州和郵政編碼: _____

電話: _____

電子郵件: _____

歧視原因: 種族 膚色 國家原生地 性別 年齡 殘疾

請提供發生歧視的日期和地點，涉嫌歧視的市政府工作人員名字以及他們的市政府職位：

請提供任何證人的姓名，地址和電話號碼: _____

請簡要解釋並盡可能清楚說明發生了什麼事，為什麼你覺得自己受到了歧視及誰參與此歧視行為? 請解釋涉嫌歧視你的工作人員對待你和其他人有什麼分別? _____

簽名

日期

請包括其他必要的證明文件。

Título VI – Procedimiento para Quejas de Discriminación

La queja se hará por escrito al Director de Obras Públicas y deberá incluir toda la información pertinente a una determinación de discriminación. La queja debe de ser presentada dentro de un término de seis (6) meses de la presunta discriminación. En casos en que el demandante no pueda o sea incapaz de proporcionar una declaración escrita, empleados de la ciudad le ayudarán a convertir la queja verbal a queja escrita. El demandante o su representante firmarán todas las quejas.

Después de revisar la queja, que incluirá entrevistar a todo el personal apropiado y al demandante, y de revisar las pólizas de la ciudad y los servicios habituales, el Director hará la determinación de la discriminación. Si se encuentra que la discriminación no ocurrió, el demandante será notificado por escrito y el procedimiento será terminado. La notificación será hecha dentro de un término de diez (10) días de la presentación de la queja. Al mismo tiempo, el demandante será aconsejado sobre su derecho de disputar la decisión del Director enviando una petición escrita solicitando una audiencia ante el Administrador de la Ciudad, dentro de un término de cinco (5) días después de recibir la determinación.

Si después que el Director ha revisado la queja, y encuentra que la discriminación puede haber ocurrido, se llevará a cabo una audiencia formal en la presencia del Administrador de la Ciudad. El demandante será notificado de ésta determinación dentro de un término de diez (10) días después de la presentación de la queja. La audiencia se llevará a cabo dentro de un término de cinco (5) días y estarán presentes el Director, el Administrador de la Ciudad, el demandante y el personal apropiado. Después de la audiencia, el Administrador de la Ciudad hará la determinación definitiva. El demandante será notificado por escrito sobre ésta determinación dentro de un término de diez (10) días después de la audiencia. Se tomará acción correctiva, si es justificada.

Si el demandante no está satisfecho con la decisión de la ciudad, el Director le aconsejará sobre su derecho de enviar su queja a la oficina de la Administración Federal de Transporte (FTA) para más investigación.

Si necesita la información en otro idioma, por favor llame al (626) 307-1320.

Title VI – Forma para Queja de Discriminación

Por favor completar y enviar al:
Director of Public Works
City of Monterey Park
320 W. Newmark Ave., Monterey Park, CA 91754

Nombre: _____

Dirección y # de Apt./Unidad: _____

Ciudad, Estado y Codigo Postal: _____

Teléfono: _____

Email: _____

Discriminación de: Raza Color Origen Nacional Sexo Edad Discapacidad

Proporcione fecha(s) y lugar de la supuesta discriminación, el nombre(s) de la persona(s) que supuestamente discriminó contra usted incluyendo sus títulos (si los sabe). _____

Proporcione nombres, direcciones y números de teléfonos de testigos.

Explique breve y claramente qué pasó, cómo se sintió al ser discriminado y quién estuvo involucrado. Explique como otras personas fueron tratadas de distinta manera que usted.

Firma

Fecha

Incluya páginas adicionales y otros documentos de respaldo como sean necesarios.



City Council Staff Report

DATE: November 16, 2022

AGENDA ITEM NO: Consent Calendar - 3G

TO: The Honorable Mayor and City Council
FROM: Shawn Igoe, Director of Public Works
SUBJECT: Approval of Second Amendment to Agreement with Mariposa Landscapes, Inc.

RECOMMENDATION:

It is recommended that the City Council consider:

1. Authorizing the City Manager to execute the Second Amendment, in a form approved by the City Attorney, that would increase the budget of the Landscape Maintenance Agreement with Mariposa Landscapes, Inc., from \$118,000 annually to an amount not to exceed \$170,000 annually. Additionally, the term of the Agreement would be extended to June 30, 2025, with an option for an additional two-year extension;
2. Taking such additional, related, action that may be desirable.

EXECUTIVE SUMMARY:

Staff is recommending that City Council approve the Second Amendment to Agreement No. 2136-A for expanding the scope of work to include city-owned water operation facilities. The additional work will increase the annual budget of the Maintenance Agreement from \$118,000 to \$170,000. This amendment will also extend the term of the Agreement to June 30, 2025, with an option to further extend the Agreement for an additional two years upon mutual consent by both parties.

BACKGROUND:

On March 6, 2019, City Council awarded a contract to Lawnscape Systems, Inc. for landscape and weed abatement at pumping plants, reservoirs and well facilities for the Water Division. Lawnscape's contract was terminated in April 2022 due to an unsustainable cost increase; it agreed to a month to month contract until the end of the fiscal year on June 30, 2022. In the interim, Public Works staff maintained the water operation sites to the best of their abilities. This arrangement is not a long-term solution due to operational demands of the water treatment and distribution system.

The Water Division approached the city-wide landscape contractor - Mariposa Landscapes – for a proposal to provide landscape maintenance and weed abatement for the preservation of Water infrastructure at Water Division sites. These include city-owned properties where wells and reservoirs are located. Its monthly proposed cost of \$4,331 is

less than Lawnscape's 2019 bid of \$5,200 per month. Mariposa has been providing landscape maintenance services to the city for nearly 15 years and its quality of service is consistently above satisfactory.

The original city-wide Agreement with Mariposa Landscapes is for an amount not to exceed \$117,984 annually for a three-year term. The First Amendment to the Agreement extended the term to June 30, 2024.

Staff is requesting approval of the Second Amendment to include landscape maintenance services at additional sites that are water operation facilities. The cost for the expanded services is \$52,000 annually, increasing the annual contract from \$118,000 to \$170,000.

The First Amendment to Mariposa's Agreement extended the term to June 30, 2024. Staff is requesting that in addition to increasing the budget of the Agreement, the Second Amendment would extend the term of Agreement to June 30, 2025, with an option for an additional two-year extension upon mutual consent by both parties. Future year costs would be adjusted by the Consumer Price Index (CPI) – average of All Urban Consumers and Urban Wage Earners - for the Los Angeles area at a maximum of five percent (5%) annually.

FISCAL IMPACT:

The cost for the expanded services under Mariposa's Second Amendment will be paid from Water Operation funds (401). The FY2023 budget includes the cost for these maintenance services; no additional appropriation is necessary.

Respectfully submitted by:



Shawn Igoe
Public Works Director

Prepared by:



Amy Ho
Principal Management Analyst

Approved by:

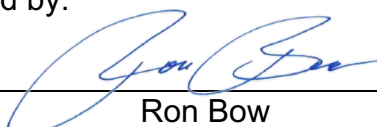

Ron Bow
City Manager

Reviewed by:



Karl H. Berger
City Attorney

ATTACHMENT

1. Mariposa Proposal for Expanded Services (October 25, 2022)

ATTACHMENT 1
Mariposa Landscapes, Inc. Proposal
(October 25, 2022)

REVISED PROPOSAL

October 25, 2022
City of Monterey Park – Water Division
320 West Newmark Ave.
Monterey Park, CA 91754
Phone # (626) 307-1298
Attn: George Noriega, Water Operations Supervisor
gnoriega@montereypark.ca.gov

Re: Landscape Maintenance Proposal at 24 water sites

- Description** This proposal provides for all labor, material, and equipment to perform Landscape Maintenance at City Monterey Park’s water sites. Proposal includes visiting site regularly to maintain landscape as described in the provided scope of work.
- Price**Please see separate pricing sheet.
- Terms:** One year term. Monthly billing.
- Exclusions:** Please see next page for exclusion and note.
- Time** Project start date is currently 30 calendar days after acceptance of this proposal or as agreed by both parties.
- Limits** Time limit for the acceptance of this proposal is 60 calendar days from the above date.

Respectfully submitted,

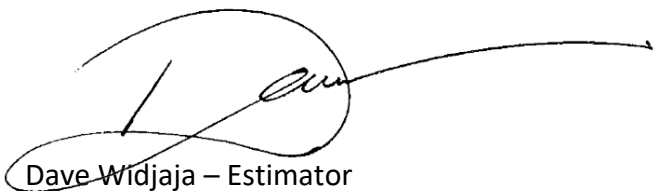

Dave Widjaja – Estimator
dave.widjaja@mariposa-ca.com
(626) 960-0196 ext. 2726 (626) 960-8477 fax

Authorized Representative Signature and Date

Landscape Maintenance Proposal Specifications

Mariposa Landscapes hereby submits the following provided work specifications for your review. This proposal provides for all labor, material and equipment to provide the following Landscape Maintenance Service. Site shall be visited per noted below. All debris generated from the work will be removed from the site. Site shall be kept well groomed and manicured.

1. **ACKLEY PUMPING PLANT – 567 Ackley Dr. (Bi-Monthly)**
 1. Trim and remove any over growth that extends inside fence line onto asphalt area.
 2. Trim and remove any over growth that extends beyond dirt area north of hydro tank
 3. Trim tree all over growth over hydro tanks.

2. **BRADSHAWE PUMPING PLANT - 1001 Bradshawe Pl. (Bi-Monthly)**
 1. Trim and remove any growth that extends inside fence line onto asphalt area.
 2. Trim all trees over growth over hydro tanks.
 3. Clean all brush within 5-feet of fence
 4. Keep slope west of site clear of tree and shrub re-growth or volunteers.
 5. Trim back and remove any over growth along service road. Maintain 15-foot width clearance. Trim back remove any over growth along concrete curbing.
 6. Trim and remove any over growth down stairway and on adjacent concrete pad.
 7. Control weeds, trim shrubs, and remove dead plant material along fence line (west side of reservoirs) (Maintain 6-foot strip centered on fence line.)
 8. Maintain irrigation system.
 9. Keep North area clear down to 20 feet past toe-of-slope (toward house at end of Bradshawe Court.). Maintain a spray program on any regrowth.
 10. Maintain acacias and keep areas free from other species (north side – 2 areas).
 11. Maintain vegetation and trees at least five (5) feet from north and west sides of reservoirs. Trim tree branches and remove volunteer trees/shrubs.
 12. Maintain vegetation and trees at north/west side of access driveway entrance (driveway border and house on Bradshwe Court).

1. **BRADSHAWE RESERVOIR (Frontage at Bradshawe Dr.) - 1001 Bradshawe Pl. (Bi-Monthly)**
 1. Control weeds, trim shrubs and remove dead plant material along fence line on Bradshawe Road. Maintain (5) feet of fence line. Remove any ground cover growing on fence over 12 inches above ground level.
 2. Maintain vegetation from top of slope to the bottom of slope (street retaining wall). Remove volunteer trees and shrubs.

2. **BRIGHTWOOD PUMPING PLANT – 1204 Bradshawe St. (Bi-Monthly)**



1. Trim back and remove all growth within five (5) feet of electrical cabinet in easement.
 2. Trim back approx. (1) feet around in ground vault cover at corner of Brightwood & Crestvista and maintain bush.
3. **COUNTRY PUMPING PLANT – 919 Country Rd. (Bi-Monthly)**
1. Trim and remove any growth that extends inside fence line onto asphalt area.
 2. Maintain irrigation and landscape at south planter and north slope.
 3. Remove vegetation from north, south, east, and west fences.
 4. Maintain sloped areas on north side to v-ditch, 2 feet south of v-ditch, in good condition. (including v-ditch).
 5. Keep small area on west side between fences clean and in good condition.
4. **HIGHLAND RESERVOIR – 1140 Highland Dr. (Bi-Monthly)**
1. Trim and remove any over growth along service road entrance.
 2. Control weeds on east dirt area up to fence lines.
 3. Trim and remove overgrowth around reservoir service road.
 4. Clear asphalt area of debris.
 5. Control weeds, trim shrubs and remove dead plant material along fence lines inside site. (Maintain a strip four (4) feet inside of fence, clear of shrubs.)
 6. Remove any ground cover growing on fence over 12 inches above ground level.
 7. North & East Slope; control weeds and remove volunteer trees/shrubs from property line to the block retaining wall.
 8. Keep v-ditch clean of debris.
5. **KINGSFORD PUMPING PLANT - 707 Kingsford St. (Bi-Monthly)**
1. Trim back and remove any over growth that extends in front of entrance.
6. **LA LOMA PUMPING PLANT and RESERVOIR - 1980 Clover Dr. (Bi-Monthly)**
1. Trim and remove any over growth that extends inside fence line onto asphalt area.
 2. Control weeds within compound on all asphalt and concrete areas.
 3. Control weeds on West dirt area up to fence.
 4. Control weeds on East dirt area up to fence.
 5. Control weeds on South dirt area up to fence.
 6. Control weeds and remove volunteer trees and shrubs on South slope up to v-ditch.
 7. Control weeds and remove volunteer trees and shrubs on East slope.
 8. Keep v-ditch clean of debris.
7. **PINE TREE RESERVOIR – 2167 Arriba Dr. (Bi-Monthly)**
1. Trim and remove any overgrowth around reservoir service road.
 2. Clear asphalt area of debris and plant material
 3. Trim shrubs 5 feet away from fence (north side).



4. Remove volunteer shrubs and trees inside fence
 5. Remove plant material growing above 12 inches on fences.
 6. Maintain irrigation system.
 7. Control weeds (spray as necessary) and remove volunteer trees/shrubs on South slope.
8. **RUSSELL PUMPING PLANT – 750 S. Russell Ave. (Bi-Monthly)**
1. Maintain landscaping and irrigation system from reservoir gate to corporate yard gate and in front of the pump station.
 2. Trim and remove any overgrowth and control weeds .
 3. Control weeds on dirt and concrete areas within pumping plant.
 4. Trim tree overgrowth within five (5) feet of hydro tanks.
 5. Remove volunteer trees and shrubs from concrete pad or pumping plant facilities, to the concrete tanks.
 6. Adjust heads and irrigation run time to give honeysuckle vines priority.
 7. Agave bubblers shall be adjusted to saturate, but not cause runoff.
1. **RUSSELL RESERVOIRS (West Side) - 750 S. Russell Ave. (Bi-Monthly)**
1. Control and treat weeds on slopes surrounding steel tank reservoirs.
 2. Maintain landscaping and irrigation system on slopes surrounding steel tank reservoirs.
 3. Control and treat weeds around trees and plants on West slope, from access road to westside fence line.
 4. Remove volunteer trees and shrubs on West slope, from access road to westside fence line.
 5. Maintain landscaping and irrigation system on Westside slope.
 6. Control weeds in asphalt access road.
 7. Clear asphalt of debris.
 8. Clear v-ditch and catch basin on Westside fence line.
1. **RUSSELL RESERVOIRS (East Side) - 750 S. Russell Ave. (Bi-Monthly)**
1. Control and treat weeds throughout all areas around concrete reservoirs, up to City yard access road. (Spray weeds as necessary, trim tree branches and remove volunteer trees/shrubs)
2. **SEQUOIA RESERVOIR – 746 Ridge Crest St.(Bi-Monthly)**
1. Control weeds around concrete reservoir inside and outside the fence. Maintain landscape outside the reservoir fence approximately ten (10) feet outside the fence.
 2. Trim ivy to within 4 ft. of fence line and off block building.
 3. Remove debris from reservoir cover and access road.
3. **SEQUOIA PUMPING PLANT – 736 S. Crest Vista St. (Bi-Monthly)**



1. Maintain landscaping and irrigation system within (5) feet of pump facility building.
4. **SOMBRERO PUMPING PLANT & RESERVOIR – 1320 Sombrero Dr. (Bi-Monthly)**
 2. Trim and remove tree over-growth to maintain clearance of service road.
 3. Trim and maintain bottle brush around access road and pump station.
 4. Control and treat weeds in dirt area from Sombrero Dr. up to fence line.
 5. Maintain area outside of fence between Sombrero Dr. and fence.
 6. Control and treat weeds in planters surrounding access road.
 7. Keep asphalt clear of debris and control weeds.
 8. Keep ivy trimmed off wooden fence along roadway entrance.
 9. Maintain irrigation system.
5. **VAGABOND PUMPING PLANT – 1490 Vagabond Dr. (Bi-Monthly)**
 1. Control and treat weeds on north hillside up to fence line.
 2. Control weeds in asphalt area inside fence line.
 3. Clear asphalt area of debris.
6. **CITY YARD – 751 S. Alhambra Av. (Bi-Weekly)**
 1. Maintain areas on south side of access road from Russell Ave to the end of Water Division pad.
 2. Remove tree/shrub volunteers and weeds within 10 feet of access road.
 3. Maintain upper pad area (water pipe storage area). Remove trees, shrubs, vines, and weeds within 10 feet of pad.
 4. Maintain lower pad area, including landscaping and irrigation system. Area includes: from Water Division office, north to road and west to storage building, and Annex planter.
 5. Keep upper and lower pad area clear of light debris and control weeds.

City of Rosemead Water Division Sites

7. **DELTA PUMPING AND TREATMENT PLANT – 2657 N. Delta Av. (Bi-Weekly)**
 1. Maintain irrigation system.
 2. Control and treat weeds inside of perimeter fence lines. (Including gravel areas and settling basin)
 3. Keep perimeter fence lines clear of groundcover and shrub penetration.
 4. Keep tree wells and sidewalks (Delta Ave and Fern street, in front of City property) clear of weeds and trash.
 5. Maintain landscaping inside of Delta site and treatment plant areas.
 6. Mow and edge rear and side grass areas.
8. **WELL 1 AND SOUTH FIELD – 2745 N. Delta Av. (Bi-Monthly)**
 1. Control and treat weeds inside of perimeter fence lines.



2. Control weeds and any shrub/tree volunteers within two planter areas.
 3. Maintain irrigation system.
 4. Keep parking lot clean (blow off dirt).
 5. Keep solar field clean.
9. **WELL 5 AND SOUTH FIELD – 2450 N. Charlotte Av. (Bi-Monthly)**
1. Control and treat weeds inside of property fence lines.
 2. Control weeds and any shrub/tree volunteers.
 3. Keep entrance, concrete, and asphalt clean (blow off dirt).
 4. Keep solar field clean.
10. **WELL 7, 8 and 9 – 8830 E. Fern Av. (Bi-Monthly)**
1. Keeps entrance clean; including concrete, asphalt, and catch basin area (blow off dirt).
 2. Keep the North and West fence clear of plants and weeds (entrance area).
11. **WELL 10 – 2719 N. Gladys Av. (Bi-Monthly)**
1. Trim and remove any tree and shrub over-growth adjacent to north fence (min. 3 feet clearance).
 2. Control weeds in dirt, gravel and asphalt areas inside fence line.
 3. Control weeds in asphalt area outside of fence line and on south corner.
 4. Clear asphalt areas of debris inside and outside of fence line.
 5. Maintain landscaping and irrigations system.
12. **WELL 12 and 15 – 8815-17 Klingerman St. (Bi-Monthly)**
1. Control and treat weeds in dirt, gravel and asphalt areas inside fence line.
 2. Maintain 8 ft. clearance under pine trees (inside fence).
 3. Treat and or remove tree and shrub regrowth/volunteers on site.
 4. Keep north block wall and west fence clear of plants.
 5. Trim tree overgrowth within 5 ft of concrete pads (air stripper, blower enclosure, chemical tank area, control cabinets).
 6. Maintain bougainvilleas on south fence
13. **WELL 14 – 8815 Rush Av. (Bi-Monthly)**
1. Control weeds and remove volunteer plants in dirt, asphalt and gravel areas in well site.
 2. Keep chain-link fence clear of plants.
 3. Maintain 8 ft clearance under pine trees.
 4. Keep asphalt clear of debris.



Exclusion and Notes

Exclusion:

- 1. No Irrigator time was added
- 2. Irrigation repairs.
- 3. Weed abatement of slopes at the back of Country and Highland is not included
- 4. Weed abatement along the back of residential at Pine Tree is not included
- 5. Pest control
- 6. Any bond or permits
- 7. Hardscape steam cleaning or pressure washing
- 8. Painting works
- 9. Tree work only limited to vehicular clearance
- 10. CWA or Union signatory single job agreement

Note:

- 1. Additional prices are given in the breakdown.
- 2. Assume bi- weekly means visit every 2 weeks.
- 3. Assume bi- monthly means visit every 2 months.
- 4. Visual checks will be conducted by foreman at each visit.

Prices

Base Landscape Maintenance (per Frequency provided)..... \$ 4,331.00 / month

Additional

Landscape Irrigation Audit \$ 1,900.00

Landscape Maintenance (Monthly visit + 2 site with bi-weekly visit)..... \$ 5,431.00 / month





City Council Staff Report

DATE: November 16, 2022

AGENDA ITEM NO: Consent Calendar - 3H

TO: The Honorable Mayor and City Council
FROM: Shawn Igoe, Director of Public Works
SUBJECT: 2022 Residential Street Rehabilitation – Award of Public Works Contract to All American Asphalt

RECOMMENDATION:

It is recommended that the City Council consider:

1. Adopting amended resolution No. 2022-R38 updating the project list for FY 22-23 SB1 rehabilitation project by adding Polk Way to the list of locations;
2. Authorizing the City Manager to execute a public works contract, in a form approved by the City Attorney, with All American Asphalt of Corona, CA in the contract amount of \$869,422 for the 2022 Residential Street Rehabilitation Project;
3. Authorizing the Director of Public Works to approve change orders and contingency up to \$86,943, or 10% of the contract amount; and,
4. Taking such additional, related action that may be desirable.

CEQA (California Environmental Quality Act):

Since the proposed work is a minor alteration to an existing public facility, this project is Class 1 Categorically Exempt pursuant to the California Environmental Quality Act (CEQA).

EXECUTIVE SUMMARY

Per Resolution No. 2022-R32, the Public Works Director solicited bids for the 2022 Residential Street Rehabilitation project, Capital Improvement Project No. 96036. The public bid opening for the 2022 Residential Street Rehabilitation Project was held on October 27, 2022. Seven bids were received: Onyx Paving, All American Asphalt, Toro Enterprises, Vance Corporation, Sequel Contractors, Inc, Hardy & Harper, and Excel Paving Co. Staff recommends that the City Council authorize the City Manager to execute a Public Works contract with All American Asphalt, the lowest responsible bidder, for the 2022 Residential Street Rehabilitation Project in the amount of \$869,422, plus 10% contingency.

BACKGROUND

On June 1, 2022, City Council approved Resolution No. 2022-R38 adding the 2022 Street Rehabilitation project to the FY22-23 budget to be funded by Senate Bill 1 (SB1) funds. The proposed project involves the rehabilitation of the following streets:

STREET SEGMENTS
Eroica Dr – Alisar Ave to End
Ackley St – Fulton Ave to Palm Ave
Polk Way – Van Buren Dr to End
McComb Way – Wilcox Ave to Kempton Ave
Vercoe Pl – Wilcox Ave to End
Riggin St – Wilcox Ave to End (East)
Fulton Ave – Pomona Blvd to Markland Dr

Resolution No. 2022-R38 did not identify Polk Way as part of the project scope. However, based on the City’s Pavement Management Program, it is recommended that the Resolution be amended to add Polk Way as part of the project list. The work includes cold milling and removal of the existing asphalt pavement and constructing a rubberized asphalt overlay, adjusting utility covers to grade; constructing new ADA curb ramps; repairing residential sidewalk, restoring traffic striping and pavement markings; and providing and maintaining traffic control during construction.

The public works bid was opened on October 27, 2022, and includes the following seven bids:

RANK	BIDDER	BASE BID AMOUNT
1	All American Asphalt	\$ 869,422
2	Onyx Paving	\$ 888,000
3	Toro Enterprises	\$ 903,668
4	Sequel Contractors, Inc.	\$916,948
5	Hardy & Harper	\$950,000
6	Palp, Inc dba Excel Paving Company	\$ 989,249
7	Vance Corporation	\$ 1,022,315.80

The bid submitted by All American Asphalt, is the lowest responsive bid from a responsible bidder. All American Asphalt’s license was verified with the California State Contractor’s License Board to be current, active and in good standing. Registration with the California Department of Industrial Relations (DIR) was verified. Staff also checked the contractor’s references and received positive feedback.

FISCAL IMPACT

This project is funded by the SB1 Road Maintenance and Rehabilitation Account (RMRA) Fund and is included in the 2022-2023 fiscal year Capital Improvement Program. There are sufficient funds under Capital Improvement Project No. 96036 to execute this public works contract.

Respectfully submitted and prepared by:



Shawn Igoe
Director of Public Works

Reviewed by:



Martha Garcia
Director of Management Services

Approved by:



Ron Bow
City Manager

Reviewed by:



Karl H. Berger
City Attorney

ATTACHMENTS

1. All American Asphalt Proposal
2. Draft Amended Resolution

Staff Report
November 16, 2022

ATTACHMENT 1
All American Asphalt Proposal

SECTION C. BIDDERS PROPOSAL
(Entire section C shall be submitted with the bid)

BIDDER'S NAME: All American Asphalt

In accordance with the City's Notice Inviting Sealed Bids, the undersigned BIDDER, hereby proposes to furnish all materials, equipment, tools, labor, and incidentals required for the above stated project as set forth in the Plans, Specifications, and contract documents therefore, and to perform all work in the manner and time prescribed therein.

BIDDER declares that this proposal is based upon careful examination of the work site, Plans, Specifications, Instructions to Bidders, and all other contract documents. If this proposal is accepted for award, BIDDER understands that failure to enter into a contract in the manner and time prescribed will result in forfeiture to the City of Monterey Park of the guarantee accompanying this proposal.

BIDDER understands that a bid is required for the entire work. The contract will be awarded on the prices shown on the bid schedule. It is agreed that the unit and/or lump sum prices bid include all appurtenant expenses, taxes, royalties and fees. In the case of discrepancies in the amounts of bid, unit prices shall govern over extended amount, and words shall govern over figures.

If awarded the Contract, the undersigned further agrees that in the event of the BIDDER'S default in executing the required contract and filing the necessary bonds and insurance certificates within ten working days after the date of the City's notice of award of contract to the BIDDER, the proceeds of the guarantee accompanying this bid shall become the property of the City and this bid and the acceptance hereof may, at the City's option, be considered null and void.

BID SCHEDULE

To the Monterey Park's City Council, herein called the "Council".

Pursuant to and in compliance with your Notice Inviting Bids and the other documents relating thereto, the undersigned bidder, having familiarized himself with the work, and with the terms of the contract, the local conditions affecting the performance of the contract, and the cost of the work at the place where the work is done, and with the drawings and specifications and other contract documents, hereby proposes and agrees to perform, within the time stipulated, the contract, including all of its component parts, and everything required to be performed, and to provide and furnish any and all of the labor, materials, tools, expendable equipment, and all applicable taxes, utility and transportation services necessary to perform the contract and complete in a workmanlike manner, all in strict conformity with the Contract Documents on file at the office of the City Clerk of said City, per the following bid schedule:

BID SCHEDULE					
For 2022 Residential Street Rehabilitation, Specification No. 2022-008					
No.	Bid Item Description	Quantity	Unit	Unit Bid	Total Bid
1	Cold Mill Existing Asphalt Pavement, 1.5" deep as shown on Appendix 4. Location Index, Detail A. Work locations are shown on Appendix 4. Location Index.	254,000	SF	\$0.57	\$ 144,780.00
2	Furnish and install 1.5" thick (ARHM) asphalt rubberized hot mix complete and in place.	2,352	TON	\$132.00	\$310,464.00
3	Furnish and install 1.5" thick asphalt concrete AC Type B level Course including tapering from 0" at gutter edge to 1.5" at 5' from gutter edge as shown on Appendix 4. Location Index, Detail A.	2,000	TON	\$114.00	\$228,000.00
4	Adjust manhole covers to grade, complete and in place.	43	EA	\$750.00	\$32,250.00
5	Adjust water/gas valves to grade, complete and in place.	34	EA	\$ 650.00	\$22,100.00
6	Remove existing and construct new PCC curb and gutter per SPPWC, Std. Plan No: 120-3, A2-8, complete and in place.	99	LF	\$105.00	\$10,395.00
7	Remove existing and construct new PCC ADA ramps per SPPWC, Std. Plan No: 111-5. Case and type is to be determined by City representative.	12	EA	\$8,000.00	\$96,000.00
8	Remove existing and construct new PCC Sidewalk, 4" thick per SPPWC, Std. Plan No. 112-2.	1,187	SF	\$14.00	\$16,618.00
9	Furnish and install traffic striping & pavement markings.	1	LS	\$5,815.00	\$5,815.00
10	Furnish and Install Construction Project Information Sign	2	EA	\$1,500.00	\$3,000.00
TOTAL BASE BID AMOUNT IN NUMBERS					\$869,422.00
TOTAL BASE BID AMOUNT IN WORDS:					
Eight hundred sixty nine thousand four hundred twenty two dollars and zero cents					

The award of Contract shall be based on the TOTAL BASE BID AMOUNT.	
In the case of discrepancies in the amount of bid, unit prices shall govern over extended amounts, and words shall govern over figures.	
Full compensation for the items listed to the right as Items A, B, C, D and E are considered as inclusive in each Bid Item listed above in the Bid Schedule as applicable, and no additional and/or separate compensation will be allowed.	A. Mobilization / Demobilization
	B. Traffic Control
	C. NPDES, WVECP, and Best Management Practices (BMPs), Public Convenience and Safety
	D. Construction Staking by Land Surveyor
	E. Clearing and Grubbing
The bid prices shall include any and all costs, including labor, materials, appurtenant expenses, taxes, royalties and any and all other incidental costs to complete the project, in compliance with the Bid and Contract Documents and all applicable codes and standards.	
The City reserves the right to add, delete, increase or decrease the amount of any quantity shown and to delete any item from the contract and pay the contractor at the bid unit prices so long as the total amount of change does not exceed 25% (plus or minus) of the total bid amount for the entire project. If the change exceeds 25%, a change order may be negotiated to adjust unit bid prices.	
All other work items not specifically listed in the bid schedule, but necessary to complete the work per bid and contract documents and all applicable codes and standards are assumed to be included in the bid prices.	
A bid is required for the entire work, that the quantities set forth in the Bid Schedule are to calculate total bid amount, and that final compensation under the contract will be based upon the actual quantities of work satisfactorily completed.	

DESIGNATION OF SUBCONTRACTORS

BIDDER proposes to subcontract certain portions of the work which are in excess of one-half of one percent of the bid and to procure materials and equipment from suppliers and vendors as follows:

Subcontractor Information	Work to be Performed	Dollar Amount
Name: Cal Stripe	#9 Traffic Striping	\$ <u>6,695.00</u>
Address: 2040 East Steel Road Colton, CA 92324		
Tel: 909-771-1261		
Name: Case Land Surveying	Survey	\$ <u>22,815.00</u>
Address: 614 N. Eckhoff St Orange, CA 92868		
Tel: 714-628-8948		
Name:		\$ _____
Address:		
Tel:		
Name:		\$ _____
Address:		
Tel:		
Name:		\$ _____
Address:		
Tel:		
Name:		\$ _____
Address:		
Tel:		
Total Subcontract Amount (shall not exceed 49% of Total Bid Amount)		\$ <u>29,510.00</u>

REFERENCES

References shall be for projects constructed by the bidding company; references for other projects performed by principals or other individuals of the bidding company may not be included. References shall be either minimum from 3 Public Agencies; or minimum from 2 Public Agencies plus 2 Private Entities for which BIDDER has performed similar work within the past three years.

Reference 1		
Agency Name City of Loma Linda	Project Name and Brief Description	
Contact Name and Title T. Jarb Thaipejr	Pavement Rehab-Barton Rd	
Tel: 909-799-4400 E-mail: jthaipejar@lomalinda-ca.gov	Contract Value: \$ <u>768,677</u>	Year Completed: <u>2020</u>

Reference 2		
Agency Name City of Jurupa Valley	Project Name and Brief Description	
Contact Name and Title Chase Keys	Granite Hill Drive Pavement Rehabilition	
Tel: 951-332-6464 E-mail: ckkeys@jurupavalley.org	Contract Value: \$ <u>999,777.00</u>	Year Completed: <u>2020</u>

Reference 3		
Agency Name City of Simi Valley	Project Name and Brief Description	
Contact Name and Title sarah shesebor	Simi Valley Minor Street Rehabilitation	
Tel: 805-583-6792 E-mail: ssheshab@simivalley.org	Contract Value: \$ <u>510,124.25</u>	Year Completed: <u>2019</u>

Reference 4		
Agency Name	Project Name and Brief Description	
Contact Name and Title	**SEE ATTACHED**	
Tel: _____ E-mail: _____	Contract Value: \$ _____	Year Completed: _____

SITE INSPECTION

The Bidder declares that he/she has carefully read and examined the plans, specifications, bid documents, and he/she has made a personal examination of the site (indicate name of the person, representing the bidder, who inspected the site and date below) and that he/she understands the exact scope of the Project without question.

Name of Person who inspected the site: Maurice Ramirez, Project Manager

Date of Inspection: 10/23/2022

ADDENDA ACKNOWLEDGMENT

The Bidder acknowledges receipt of the following Addenda and has included their provisions in this Proposal:

- Addendum No. 1 Dated 10/7/2022
- Addendum No. 2 Dated 10/17/2022
- Addendum No. _____ Dated _____
- Addendum No. _____ Dated _____
- Addendum No. _____ Dated _____
- Addendum No. _____ Dated _____

2020

PAST WORK REFERENCES

City of Victorville
14343 Civic Drive
Victorville CA. 92393
Contact: Bruce Miller 760-955-5085
bmiller@victorvilleca.gov

Third Avenue Road Improvements
Contract Amount: \$1,790,000.00
Start Date: 5/2020
End Date: 10/2020

Orange County Cemetery District
25751 Trabuco Rd.
Lake Forest CA. 92630
Contact: Jim Mickartz 949-450-1088
mickartzarch@gmail.com

El Toro Memorial Park Curb & Dr. Project
Contract Amount: \$416,999.99
Start Date: 08/2020
End Date: 11/2020

City of Alhambra
111 S. 1st Street
Alhambra, CA. 91801
Contact: Robert Bias 626-580-5000
rbias@cityofalhambra.org

2020 HUD Street Improvements Project
Contract Amount: \$300,433.00
Start Date: 06/2020
End Date: 10/2020

City of Ontario
303 E. B Street
Ontario, CA. 91764
Contact: Ariana Kern 909-395-2129
akern@ontarioca.gov

2020 Fall Pavement Rehabilitation Project
Contract Amount: \$2,499,333.00
Start Date: 07/2020
End Date: 12/2020

City of Loma Linda
25541 Barton Road
Loma Linda, CA. 92354
Contact: T. Jarb Thaipejr 909-799-4400
jthaipejr@lomalinda-ca.gov

Pavement Rehabilitation –Barton Road
Contract Amount: \$768,677.00
Start Date: 04/2020
End Date: 12/2020

City of Jurupa Valley
8920 Limonite Avenue
Jurupa Valley, CA. 92509
Contact: Chase Keys 951-332-6464
ckeys@jurupavalley.org

Granite Hill Drive Pavement Rehabilitation
Contract Amount: \$999,777.00
Start Date: 04/2020
End Date: 10/2020

2020

PAST WORK REFERENCES

City of Camarillo
601 Carmen Drive
Camarillo, CA 93010
Contact: Thang Tran (805) 388-5345
ttran@cityofcamarillo.org

Earl Joseph Drive Paving
Contract Amount: \$681,901.50
Start Date: 06/2020
End Date: 07/2020

County of Ventura
800 S. Victoria Avenue, #1600
Ventura, CA 93009
Contact: Matt Maechler (805) 477-1911
matthew.maechler@ventura.org

Yerba Buena Rd. (South) Pavement
Resurfacing
Contract Amount: \$2,298,467.40
Start Date: 03/2020
End Date: 06/2020

City of Westminster
8200 Westminster Boulevard
Westminster, CA 92683
Contact: Theresa Tran (714) 548-3460
ttran@westminster.ca.gov

Citywide Overlay Street Improvements
Contract Amount: \$1,131,621
Start Date: 02/2020
End Date: 06/2020

City of Newport Beach
100 Civic Center Drive
Newport Beach, CA 92660
Contact: Patricia Kharazmi (949) 644-3344
pkharazmi@newportbeachca.gov

Cameo Highlands Street Reconstruction
Contract Amount: \$2,425,694.00
Start Date: 07/2020
End Time: 11/2020

City of Huntington Beach
2000 Main Street
Huntington Beach, CA 92648
Contact: Joe Fuentes (714) 536-5259
jfuentes@surfcity-hb.org

Arterial Rehabilitation of Graham St, Slater
Ave, Newland St and Atlanta Ave
Contract Amount: \$5,181,955.00
Start Date: 05/2020
End Date: 11/2020

County of Orange
601 N. Ross Street, 4th Floor
Santa Ana, CA 92701
Contact: Albert Rodriguez
albert.rodriguez@ocpw.ocgov.com

JOC Pavement Maintenance
Contract Amount: \$2,584,747.69
Start Date: 07/2020
End Date: 08/2020

2020

PAST WORK REFERENCES

City of Orange
300 E. Chapman Avenue
Orange, CA 92886
Contact: Martin Varona (714) 744-5563
mvarona@cityoforange.org

Annual Slurry Seal FY 19-20
Contract Amount: \$377,737.78
Start Date: 06/2020
End Date: 12/2020

City of Norco
2870 Clark Avenue Norco, CA 92860
Contact: Sam Nelson (951) 270-5607
snelson@ci.norco.ca.us

FY 2019-2020 Slurry Seal Project
Contract Amount: \$147,708.97
Start Date: 06/2020
End Date: 12/2020

City of Compton
205 S. Willowbrook Avenue
Compton, CA 90220
Contact: Brittany Duhn (Z & K Consultants)
bduhn@zandkconsultants.com

Annual Residential Street Rehab – Phase 1
Contract Amount: \$5,295,068.00
Start Date: 05/2020
End Date: 11/2020

EQUAL EMPLOYMENT OPPORTUNITY COMPLIANCE

BIDDER certifies that all previous contracts or subcontracts, all reports which may have been due under the requirements of any Agency, Site, or Federal equal employment opportunity orders have been satisfactorily filed, and that no such reports are currently outstanding.

AFFIRMATIVE ACTION CERTIFICATION

BIDDER certifies that affirmative action has been taken to seek out and consider minority business enterprises for those portions of work to be subcontracted, and that such affirmative actions have been fully documented, that said documentation is open to inspection, and that said affirmative action will remain in effect for the life of any contract awarded hereunder. Furthermore, BIDDER certifies that affirmative action will be taken to meet all equal employment opportunity requirements of the contract documents.



ALL AMERICAN ASPHALT
ALL AMERICAN AGGREGATES

T 951-736-7600 F 951-739-4671
P.O. BOX 2229, CORONA, CA 92678-2229
CONTRACTORS LICENSE #267073-AL12
DIR #1000001051

EEO-AFFIRMATIVE ACTION PROGRAM - BASIC POLICY

TO ALL AMERICAN ASPHALT PERSONNEL:

IT IS THE STATED POLICY OF ALL AMERICAN ASPHALT THAT ALL EMPLOYEES AND APPLICANTS SHALL RECEIVE EQUAL CONSIDERATION AND TREATMENT. ALL RECRUITMENT, HIRING, PLACEMENT, TRANSFER AND PROMOTIONS WILL BE ON THE BASIS OF QUALIFICATIONS OF THE INDIVIDUAL FOR THE POSITION BEING FILLED WITHOUT REGARD TO RACE, COLOR, RELIGION, SEX, SEXUAL ORIENTATION, MARITAL STATUS, NATIONAL ORIGIN, ANCESTRY, DISABILITY (MENTAL AND PHYSICAL, INCLUDING HIV AND AIDS), MEDICAL CONDITION (CANCER AND GENETIC CHARACTERISTICS), AND/OR AGE (40 AND OVER). ALL OTHER PERSONNEL ACTIONS, SUCH AS COMPENSATION, BENEFITS, LAYOFFS, RETURN FROM LAYOFF, TERMINATIONS, TRAINING AND SOCIAL AND RECREATIONAL PROGRAMS ARE ADMINISTERED WITHOUT REGARD TO RACE, COLOR, RELIGION, SEX, SEXUAL ORIENTATION, MARITAL STATUS, NATIONAL ORIGIN, ANCESTRY, DISABILITY (MENTAL AND PHYSICAL, INCLUDING HIV AND AIDS), MEDICAL CONDITION (CANCER AND GENETIC CHARACTERISTICS), AND/OR AGE (40 AND OVER).

EQUAL OPPORTUNITY IS A CONTINUING EFFORT AND REQUIRES THE FULL SUPPORT OF ALL OF US TO ENSURE THE DEVELOPMENT OF OUR MINORITY AND FEMALE EMPLOYEES. EACH POSSIBILITY TO HIRE OR PROMOTE SHOULD BE VIEWED AS AN OPPORTUNITY TOWARD OUR GOAL OF A FULLER UTILIZATION OF OUR MINORITY AND FEMALE EMPLOYEES. EACH MANAGER WILL COMMUNICATE TO EMPLOYEES THAT OUR COMMITMENT TO AN AFFIRMATIVE ACTION PROGRAM IS REAL, IS SUPPORTED BY OUR COMPANY, AND HAS A HIGH PRIORITY. WE ENCOURAGE ALL OF OUR EMPLOYEES TO PARTICIPATE IN THIS EFFORT BY ENCOURAGING MINORITIES AND FEMALES TO APPLY FOR EMPLOYMENT AND TO SEEK PROMOTIONS.

FOR ASSISTANCE IN THE EQUAL OPPORTUNITY PROGRAM, MANAGERS AND EMPLOYEES SHOULD CONTACT MARK LUER, EEO COORDINATOR AT (951) 736-7600. HE HAS THE SPECIFIC RESPONSIBILITIES TO MONITOR AND ASSESS THE PROGRESS FOR OUR EQUAL EMPLOYMENT OPPORTUNITY AND AFFIRMATIVE ACTION PROGRAMS.

MARK LUER
PRESIDENT

December 7, 2011



CONTRACTORS
STATE LICENSE BOARD
ACTIVE LICENSE



License Number **267073**

Entity **CORP**

Business Name **ALL AMERICAN ASPHALT**

Classification **A C12**



Expiration Date **01/31/2024**

www.csib.ca.gov

INSURANCE REQUIREMENTS

To be awarded this contract, the successful bidder shall procure and maintain the following types of insurance with coverage limits complying, at a minimum, with the limits set forth below:

<u>Type of Insurance</u>	<u>Limits</u>
Commercial general liability:	\$2,000,000
Business automobile liability	\$1,000,000
Workers compensation	Statutory requirement.

Commercial general liability insurance shall meet or exceed the requirements of ISO-CGL Form No. CG 00 01 11 85 or 88. The amount of insurance set forth above shall be a combined single limit per occurrence for bodily injury, personal injury, and property damage for the policy coverage. Liability policies shall be endorsed to name the City, its officials, and employees as "additional insureds" under said insurance coverage and to state that such insurance will be deemed "primary" such that any other insurance that may be carried by the City will be excess thereto. Such endorsement shall be reflected on ISO Form No. CG 20 10 11 85 or 88, or equivalent. Such insurance shall be on an "occurrence," not a "claims made," basis and will not be cancelable or subject to reduction except upon thirty (30) days prior written notice to the City.

Automobile coverage shall be written on ISO Business Auto Coverage Form CA 00 01 06 92, including symbol 1 (Any Auto).

The Contractor shall furnish to the City duly authenticated Certificates of Insurance evidencing maintenance of the insurance required under this Agreement, endorsements as required herein, and such other evidence of insurance or copies of policies as may be reasonably required by the City from time to time. Insurance shall be placed with admitted insurers with a current A.M. Best Company Rating equivalent to at least a Rating of "A:VII." Certificate(s) shall reflect that the insurer will provide thirty (30) day notice of any cancellation of coverage. The Contractor shall require its insurer to modify such certificates to delete any exculpatory wording stating that failure of the insurer to mail written notice of cancellation imposes no obligation, and to delete the word "endeavor" with regard to any notice provisions.

By signing this form, the bidder certifies that it has read, understands, and will comply with these insurance requirements if it is selected as the City's Contractor. Failure to provide this insurance will render the bidder's proposal "nonresponsive."

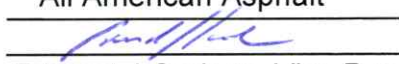
Bidder's Name:	<u>All American Asphalt</u>
Authorized Signature:	<u></u>
Name and Title:	<u>Edward J Carlson, Vice President</u>
Date:	<u>10/25/2022</u>

CALIFORNIA ALL-PURPOSE ACKNOWLEDGEMENT

CIVIL CODE § 1189

A notary public or other officer completing this certificate verifies only the identity of the individual who signed the document to which this certificate is attached, and not the truthfulness, accuracy, or validity of that document.

State of California

County of Riverside

On October 25, 2022 before me, B. Royster, Notary Public
Date Here Insert name and Title of the Officer

personally appeared Edward J. Carlson
Name(s) of Signer(s)

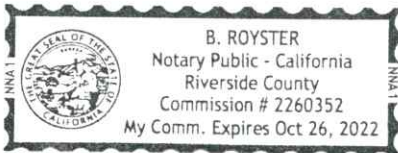

who proved to me on the basis of satisfactory evidence to be the person(s) whose name(s) is/are subscribed to the within instrument and acknowledged to me that he/she/they executed the same in his/her/their authorized capacity(ies), and that by his/her/their signature(s) on the instrument the person(s), or the entity upon behalf of which the person(s) acted, executed the instrument.

I certify under PENALTY OF PERJURY under the laws of the State of California that the forgoing paragraph is true and correct.

WITNESS my hand and official seal.
Signature B. Royster
Signature of Notary Public

Place Notary Seal Above

OPTIONAL

Though the information below is not required by law, it may prove valuable to person relying on the document and could prevent fraudulent removal and reattachment of this form to another document.

Description of Attached Document

Title or Type of Document Noncollusion Declaration – City of Monterey Park

Document Date: October 25, 2022 Number of Pages: 1

Signer(s) Other Than Named Above: None

Capacity(ies) Claimed by Signer(s)

Signer's Name: Edward J. Carlson

- Individual
- Corporate Officer – Title(s): Vice President
- Partner Limited General
- Attorney in Fact
- Trustee
- Other: _____

RIGHT THUMBPRINT OF SIGNER
Top of thumb here

Signer is Representing:
All American Asphalt

Signer's Name: _____

- Individual
- Corporate Officer – Title(s): _____
- Partner Limited General
- Attorney in Fact
- Trustee
- Other: _____

RIGHT THUMBPRINT OF SIGNER
Top of thumb here

Signer is Representing: _____

PUBLIC CONTRACT CODE SECTION 10162

In conformance with the above Public Contract Code Section, the bidder hereby declares under penalty of perjury under the laws of the State of California that the bidder any officer of such bidder, or any employee of such bidder who has a proprietary interest in such bidder

has never been **has been** (indicate YES or NO after applicable answer)

disqualified, removed, or otherwise prevented from bidding on, or completing a federal, state, or local government project because of a violation of law or a safety regulation, and if so to explain the circumstances.

If the answer is **has been** YES explain the circumstances below:

N/A

Bidder's Name: All American Asphalt

Authorized Signature: 

Name and Title: Edward J Carlson, Vice President

Date: 10/25/2022

PUBLIC CONTRACT CODE SECTION 10232

In conformance with above Public Contract Code Section, the bidder hereby declares under penalty of perjury under the laws of the State of California that no more than one final, unappealable finding of contempt of court by a federal court

has not been has been (indicate YES or NO after applicable answer)

issued against the bidder within the immediately preceding two-year period because of the contractor's failure to comply with an order of a federal court which orders the contractor to comply with an order of the National Labor Relations Board. For purposes of this section, a finding of contempt does not include any finding which has been vacated, dismissed, or otherwise removed by the court because the contractor has complied with the order which was the basis for the finding.

Bidder's Name: All American Asphalt
Authorized Signature: 
Name and Title: Edward J Carlson, Vice President
Date: 10/25/2022

PUBLIC CONTRACT CODE SECTION 10285.1

In conformance with above Public Contract Code Section, the bidder hereby declares under penalty of perjury under the laws of the State of California that the bidder or any partner, member, officer, director, responsible managing officer, or responsible managing employee thereof

has never been **has been** (indicate YES or NO after applicable answer)

convicted within the preceding three years by a court of competent jurisdiction of any charge of fraud, bribery, collusion, conspiracy, or any other act in violation of any state or federal antitrust law in connection with the bidding upon, award of, or performance of, any public works contract, as defined in Public Contract Code Section 1101, with any public entity, as defined in Public Contract Code Section 1100, including, for the purposes of this article, the Regents of the University of California or the Trustees of the California State University.

Bidder's Name:	<u>All American Asphalt</u>
Authorized Signature:	<u></u>
Name and Title:	<u>Edward J Carlson, Vice President</u>
Date:	<u>10/25/2022</u>

BIDDER INFORMATION

Bidder's Name: All American Asphalt

Address: 400 East Sixth St Corona, Ca 92879

Form of Legal Entity: Corporation

If a Corporation, State of Incorporation: California

State Contractor's Class and License No.: 267073

Contact Person Information:

Name: Edward J Carlson Title: Vice President

E-mail: publicworks@allamericanasphalt.com Tel: 951-736-7600

The following are the names, titles, addresses, and phone numbers of all individuals, firm members, partners, joint venturers, and/or corporate officers having a principal interest in this proposal:

Mark Luer President 400 East Sixth St Corona, CA 92879 951-736-7600

Edward J Carlson, Vice President 400 East Sixth St Corona, CA 92879 951-736-7600

Michael Farkas, Secretary 400 East Sixth St Corona, CA 92879 951-736-79600

The date(s) of any voluntary or involuntary bankruptcy judgements against any principal having an interest in this proposal are as follows:

N/A

All current and prior DBA'S, alias, and/or fictitious business names for any principal having an interest in this proposal are as follows:

N/A

Previous contract performance history:

Was any contract terminated previously: **N/A**

If the answer to the above is "yes", provide the following information:

A notary public or other officer completing this certificate verifies only the identity of the individual who signed the document to which this certificate is attached, and not the truthfulness, accuracy, or validity of that document.

State of California

County of Riverside

Subscribed and sworn to (or affirmed) before me on this 25th day of October, 2022,
Date Month

By (1) Edward J. Carlson
Name of Signer

Proved to me on the basis of satisfactory evidence be the person who appeared before me (.) (,)

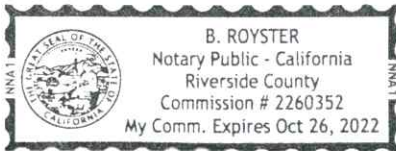

(and

(2) _____
Name of Signer

Proved to me on the basis of satisfactory evidence be the person who appeared before me.)

Signature B. Royster
Signature of Notary Public

Place Notary Seal Above

OPTIONAL

Though the information below is not required by law, it may prove valuable to person relying on the document and could prevent fraudulent removal and reattachment of this form to another document.

Further Description of Any Attached Document

Title or Type of Document Bidder Information

Document Date: 10-25-2022 Number of Pages: 1

Signer(s) Other Than Named Above: None

RIGHT THUMBPRINT OF SIGNER
Top of thumb here

RIGHT THUMBPRINT OF SIGNER
Top of thumb here

Bid Date: 10/27/2022

PROPOSAL GUARANTEE

BID BOND

Bond No.: 08597423

KNOW ALL MEN BY THESE PRESENTS that All American Asphalt, as BIDDER, AND Fidelity and Deposit Company of Maryland, as SURETY, are held and firmly bound unto the City of Monterey Park, in the penal sum of Ten Percent of Total Amount Bid --- (\$ 10% of Bid---) dollars, lawful money of the United States, which is 10 percent of the total amount bid by BIDDER to the City of Monterey Park for the **2022 RESIDENTIAL STREET REHABILITATION SPECIFICATION NO. 2022-008** ("Public Project"), for the payment of which sum, BIDDER and SURETY agree to be bound, jointly and severally, firm by these presents.

THE CONDITIONS OF THIS OBLIGATION ARE SUCH that, whereas BIDDER is about to submit a bid to the City of Monterey Park for the above stated project, if said bid is rejected, or if said bid is accepted and a contract is awarded and entered into by BIDDER in the manner and time specified, then this obligation shall be null and void, otherwise it shall remain in full force and effect in favor of the City of Monterey Park.

IN WITNESS WHEREOF the parties hereto have set their names, titles, hands, and seals this 21st day of October, 2022.

SIGNED AND SEALED this 21st day of October, 2022.

All American Asphalt

Fidelity and Deposit Company of Maryland

Edward J Carlson, Vice President
PRINCIPAL SURETY

Rebecca Haas-Bates
Rebecca Haas-Bates, Attorney-in-Fact

PRINCIPAL's MAILING ADDRESS:

SURETY's MAILING ADDRESS:

400 East Sixth Street

777 S. Figueroa Street, Suite 3900

Corona, CA 92879

Los Angeles, CA 90017

NOTE: All signatures shall be acknowledged by a notary public.

CALIFORNIA ALL-PURPOSE ACKNOWLEDGEMENT

CIVIL CODE § 1189

A notary public or other officer completing this certificate verifies only the identity of the individual who signed the document to which this certificate is attached, and not the truthfulness, accuracy, or validity of that document.

State of California

County of Riverside

On October 25, 2022 before me, B. Royster, Notary Public
Date Here Insert name and Title of the Officer

personally appeared Edward J. Carlson
Name of Signer(s)

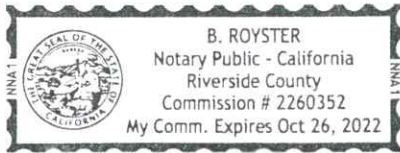

who proved to me on the basis of satisfactory evidence to be the person(s) whose name(s) is/are subscribed to the within instrument and acknowledged to me that he/she/they executed the same in his/her/their authorized capacity(ies), and that by his/her/their signature(s) on the instrument the person(s), or the entity upon behalf of which the person(s) acted, executed the instrument.

I certify under PENALTY OF PERJURY under the laws of the State of California that the forgoing paragraph is true and correct.

WITNESS my hand and official seal.

Signature B. Royster
Signature of Notary Public

Place Notary Seal Above

OPTIONAL

Though the information below is not required by law, it may prove valuable to person relying on the document and could prevent fraudulent removal and reattachment of this form to another document.

Description of Attached Document

Title or Type of Document Bid Bond – City of Monterey Park

Document Date: October 21, 2022 Number of Pages: 3

Signer(s) Other Than Named Above: Rebecca Haas-Bates, Attorney-in-Fact

Capacity(ies) Claimed by Signer(s)

Signer's Name: Edward J. Carlson

- Individual
- Corporate Officer – Title(s): Vice President
- Partner Limited General
- Attorney in Fact
- Trustee
- Other: _____

RIGHT THUMBPRINT OF SIGNER
Top of thumb here

Signer is Representing:
All American Asphalt

Signer's Name: _____

- Individual
- Corporate Officer – Title(s): _____
- Partner Limited General
- Attorney in Fact
- Trustee
- Other: _____

RIGHT THUMBPRINT OF SIGNER
Top of thumb here

Signer is Representing: _____

CALIFORNIA ALL-PURPOSE ACKNOWLEDGMENT

CIVIL CODE § 1189

A notary public or other officer completing this certificate verifies only the identity of the individual who signed the document to which this certificate is attached, and not the truthfulness, accuracy, or validity of that document.

State of California)
County of Orange)

On 10/21/2022 before me, Alma Karen Hernandez, Notary Public
Date Here Insert Name and Title of the Officer

personally appeared Rebecca Haas-Bates
Name(s) of Signer(s)

who proved to me on the basis of satisfactory evidence to be the person(s) whose name(s) is/are subscribed to the within instrument and acknowledged to me that he/she/they executed the same in his/her/their authorized capacity(ies), and that by his/her/their signature(s) on the instrument the person(s), or the entity upon behalf of which the person(s) acted, executed the instrument.

I certify under PENALTY OF PERJURY under the laws of the State of California that the foregoing paragraph is true and correct.

WITNESS my hand and official seal.



Signature [Handwritten Signature]
Signature of Notary Public

Place Notary Seal Above

OPTIONAL

Though this section is optional, completing this information can deter alteration of the document or fraudulent reattachment of this form to an unintended document.

Description of Attached Document

Title or Type of Document: Bid Bond Document Date: 10/21/2022
Number of Pages: One(1) Signer(s) Other Than Named Above: All American Asphalt

Capacity(ies) Claimed by Signer(s)

Signer's Name: Rebecca Haas-Bates
 Corporate Officer — Title(s): _____
 Partner — Limited General
 Individual Attorney in Fact
 Trustee Guardian or Conservator
 Other: _____
Signer Is Representing: _____
Fidelity and Deposit Company of Maryland

Signer's Name: _____
 Corporate Officer — Title(s): _____
 Partner — Limited General
 Individual Attorney in Fact
 Trustee Guardian or Conservator
 Other: _____
Signer Is Representing: _____

EXTRACT FROM BY-LAWS OF THE COMPANIES

"Article V, Section 8, Attorneys-in-Fact. The Chief Executive Officer, the President, or any Executive Vice President or Vice President may, by written instrument under the attested corporate seal, appoint attorneys-in-fact with authority to execute bonds, policies, recognizances, stipulations, undertakings, or other like instruments on behalf of the Company, and may authorize any officer or any such attorney-in-fact to affix the corporate seal thereto; and may with or without cause modify or revoke any such appointment or authority at any time."

CERTIFICATE

I, the undersigned, Secretary of the ZURICH AMERICAN INSURANCE COMPANY, the COLONIAL AMERICAN CASUALTY AND SURETY COMPANY, and the FIDELITY AND DEPOSIT COMPANY OF MARYLAND, do hereby certify that the foregoing Power of Attorney is still in full force and effect on the date of this certificate; and I do further certify that Article V, Section 8, of the By-Laws of the Companies is still in force.

This Power of Attorney and Certificate may be signed by facsimile under and by authority of the following resolution of the Board of Directors of the ZURICH AMERICAN INSURANCE COMPANY at a meeting duly called and held on the 15th day of December 1998.

RESOLVED: "That the signature of the President or a Vice President and the attesting signature of a Secretary or an Assistant Secretary and the Seal of the Company may be affixed by facsimile on any Power of Attorney...Any such Power or any certificate thereof bearing such facsimile signature and seal shall be valid and binding on the Company."

This Power of Attorney and Certificate may be signed by facsimile under and by authority of the following resolution of the Board of Directors of the COLONIAL AMERICAN CASUALTY AND SURETY COMPANY at a meeting duly called and held on the 5th day of May, 1994, and the following resolution of the Board of Directors of the FIDELITY AND DEPOSIT COMPANY OF MARYLAND at a meeting duly called and held on the 10th day of May, 1990.

RESOLVED: "That the facsimile or mechanically reproduced seal of the company and facsimile or mechanically reproduced signature of any Vice-President, Secretary, or Assistant Secretary of the Company, whether made heretofore or hereafter, wherever appearing upon a certified copy of any power of attorney issued by the Company, shall be valid and binding upon the Company with the same force and effect as though manually affixed.

IN TESTIMONY WHEREOF, I have hereunto subscribed my name and affixed the corporate seals of the said Companies, this 21st day of October, 2022.



By: Brian M. Hodges
Vice President

TO REPORT A CLAIM WITH REGARD TO A SURETY BOND, PLEASE SUBMIT A COMPLETE DESCRIPTION OF THE CLAIM INCLUDING THE PRINCIPAL ON THE BOND, THE BOND NUMBER, AND YOUR CONTACT INFORMATION TO:

Zurich Surety Claims
1299 Zurich Way
Schaumburg, IL 60196-1056
www.reportsfclaims@zurichna.com
800-626-4577

PROPOSAL GUARANTEE

CERTIFIED CHECK or CASHIER'S CHECK

As an Alternative to Bid Bond, Bidder can provide Certified Check or Cashier's Check as follows

Accompanying this proposal is a certified check or a cashier's check payable to the order of the City of Monterey Park, in the amount of **BID BOND INCLUDED ** (\$) dollars, lawful money of the United States, which is 10 percent of the total amount bid by BIDDER to the City of Monterey Park for the **2022 RESIDENTIAL STREET REHABILITATION SPECIFICATION NO. 2022-008** ("Public Project").

The proceeds of the same shall become the property of said City if, in case this proposal shall be accepted by said City through the City Council, the undersigned shall fail to execute a contract, with and furnish the insurance and bonds required by the City of Monterey Park within the specified time; otherwise, the same is to be returned to the undersigned as set forth in the Instructions to Bidders.

Bidder's Name: All American Asphalt

Authorized Signature: N/A

Name and Title: Edward J Carlson, Vice President

Date: 10/25/2022

--END OF SECTION--

ATTACHMENT 2
Draft Amended Resolution

RESOLUTION NO.

A RESOLUTION IDENTIFYING A STREET MAINTENANCE PROJECT TO BE INCLUDED IN THE FY 2022-23 BUDGET AND FUNDED BY SENATE BILL 1: ROAD REPAIR AND ACCOUNTABILITY ACT OF 2017

THE CITY COUNCIL RESOLVES AS FOLLOWS:

SECTION 1. The City Council finds as follows:

- A. The Road Repair and Accountability Act of 2017 was adopted to address the significant multi-modal transportation funding shortfalls statewide.
- B. The includes accountability and transparency provisions that will ensure the residents of the City are aware of the projects proposed for funding in our community and which projects have been completed each fiscal year.
- C. The City must adopt, by resolution, a list of projects proposed to receive fiscal year funding from the Road Maintenance and Rehabilitation Account (RMRA), created by the Act, which must include a description and the location of each proposed project, a proposed schedule for the project's completion, and the estimated useful life of the improvement.
- D. The City will receive an estimated \$1,376,342 in RMRA funding in Fiscal Year 2022-23.
- E. This is the sixth year in which the City is receiving such funding and will enable the City to continue essential road maintenance and rehabilitation projects, safety improvements, repairing and replacing aging bridges, and increasing access and mobility options for the traveling public that would not have otherwise been possible without the Act.
- F. The City used a Pavement Management Program to help develop the RMRA project list to ensure revenues are being used on the most high-priority and cost-effective projects that also meet the communities priorities for transportation investment.
- G. The funding from the Act will help the City maintain and rehabilitate its streets throughout the City this year and several similar projects into the future. This revenue will help the City increase the overall quality of our road system over the next decade.
- H. Cities and counties own and operate more than 81 percent of streets and roads in California, and from the moment we open our front door to drive to

work, bike to school, or walk to the bus station, people are dependent upon a safe, reliable local transportation network.

- I. The project list and overall investment in the City's local streets and roads infrastructure with a focus on basic maintenance and safety and investing in complete streets infrastructure will have significant positive co-benefits statewide.

SECTION 2. The Operating Budget for fiscal year 2022-2023 will incorporate the following project planned to be funded with Road Maintenance and Rehabilitation Account revenues:

Project: Various Street Rehabilitation

Description: Cold mill asphalt concrete pavement and construct conventional and rubberized asphalt concrete overlay on various local streets. Work includes but is not limited to asphalt grind and overlay, concrete curb, gutter, sidewalk, and curb ramps repair or replacement.

Location: Ackley Street, Keller Street, Langley Way, Kenton Drive, Fulton Avenue, Berkebile Court, McComb Wy, Riggin Street, Aztec Way, Clover Drive, Eroica Drive, Kempton Drive, Vercoe Place, **Polk Way.**

Estimated Useful Life: 15-20 years

Est. Year of Construction/Completion: Fiscal Year 2022-2023

SECTION 3. If any part of this Resolution or its application is deemed invalid by a court of competent jurisdiction, the City Council intends that such invalidity will not affect the effectiveness of the remaining provisions or applications and, to this end, the provisions of this Resolution are severable.

SECTION 4. This Resolution may be executed with electronic signatures in accordance with Government Code §16.5. Such electronic signatures will be treated in all respects as having the same effect as an original signature.

SECTION 5. The City Clerk is directed to certify the adoption of this Resolution.

SECTION 6. To the extent that any other resolution is incorporated into this Resolution, it is superseded or amended in its entirety.

SECTION 7. This Resolution takes effect immediately upon its adoption.

PASSED, APPROVED AND ADOPTED this 16th of November 2022.

Henry Lo, Mayor

ATTEST:

Vincent D. Chang, City Clerk

APPROVED AS TO FORM:



Karl H. Berger, City Attorney



City Council Staff Report

DATE: November 16, 2022

AGENDA ITEM NO: Consent Calendar - 31

TO: The Honorable Mayor and City Council
FROM: Shawn Igoe, Director of Public Works
Steven Sizemore, Interim Director of Community Development
SUBJECT: Task Orders to Public Works On-call Agreement with Transtech Engineers for Staff Augmentation and Plan Check Services

RECOMMENDATION:

It is recommended that the City Council consider:

1. Authorizing the City Manager to execute Task Order 1 per Transtech Engineers On-call Agreement No. 2282-A, in a form approved by the City Attorney, for staff augmentation in the Public Works department, not to exceed \$600,000 annually;
2. Authorizing the City Manager to execute Task Order 2 per Transtech Engineers On-call Agreement No. 2282-A, in a form approved by the City Attorney, for staff augmentation in the Community Development department, not to exceed \$210,000 annually;
3. Authorizing the City Manager to execute Task Order 3 per Transtech Engineers On-call Agreement No. 2282-A, in a form approved by the City Attorney, for Plan Check Services, not to exceed \$692,000 annually;
4. Appropriating \$237,000 from the General Fund to cover costs for Task Order 3 – Plan Check Services; and
5. Taking such additional, related, action that may be desirable.

EXECUTIVE SUMMARY:

On January 19, 2022, the City Council approved Agreement No. 2282-A with Transtech Engineers Inc. for on-call General Engineering Services.

Staff requests approval of two Task Orders to this Agreement for staff augmentation services to help the Public Works and Community Development departments fill vacant positions. The first Task Order would provide engineering staff to the Public Works department to help with project management services for Capital Improvement Projects and other general engineering services. Task Order one would be funded partially by salary savings and projects' budget, as assigned. The second Task Order would provide Building & Safety staff to the Community Development department to provide development review services for private projects. Additionally, staff requests a third task order for plan check services for private development projects. Contract services are necessary for continued services until vacant positions are filled.

BACKGROUND:

As a result of continued vacancies in the City, Transtech Engineers has been asked to provide staffing support to the City's Public Works and Community Development departments. Transtech staff is highly experienced, knowledgeable of City projects, and has provided excellent support to both departments. Due to challenges in recruitment, the City still has several vacant positions in each department and needs to continue services. Staff requests approval for two Task Orders to Transtech On-call agreement 2282-A for additional project management and staff augmentation services.

Task Order 1 for the Public Works department is proposed to obtain project management services from two Associate Engineers and one Project Manager. Each of the Associate Engineers will assist with Capital Improvement projects and general engineering services. The Project Manager will provide high level management of the City's Capital Improvement Plan, Engineering division and other duties as assigned. This task order would be funded by salary savings and specific project budgets as assigned. It is anticipated that 60% will be funded by the CIP budget and 40% would be funded through salary savings resulting from current Public Works vacancies.

Task Order 2 for the Community Development department is proposed to obtain Building & Safety Division supervision and inspection services from one Building Official and one Building Inspector. The Building Official will oversee the Building Division operations by supervising two Permit Technicians and one Building Inspector, and ensuring that operations are in accordance with best practices and compliant with the Monterey Park Municipal Code ("MPMC") and construction codes. The Building Inspector will be responsible for ensuring that development projects undergoing construction are built in accordance with the approved construction plans and are compliant with the MPMC and construction codes. This task order would be funded by salary savings available as a result of vacant positions.

Task Order 3 is proposed to obtain plan check services for private projects. Plan Check services are needed to provide timely services to the community and include reviewing construction plans for new developments within the City to ensure that the construction will be compliant with the MPMC and applicable constructions codes. The City collects plan check fees, which are designed to off-set the City's costs for planning and development services, from applicants submitting construction plans to the City for review and potential approval. Those fees are expected to off-set the City's payments made to Transtech, i.e., the services provided by Transtech under these Task Orders is anticipated to be cost neutral for the City. While the City should realize this off-set as fees are collected, a budget appropriation is needed to ensure that Transtech is compensated on a go forward basis. Consequently, an additional appropriation of \$237,000 from the General Fund is requested to execute this task order. This is based upon an unexpected increase in private construction activity; this uptick in applications was not anticipated at the time the original appropriation was requested in January 2022.

Transtech Engineers was awarded a three-year contract, on January 19, 2022, for on-call engineering support services. The proposed request for two Task Orders for staff augmentation services and one task order for plan check services are for a combined not to exceed annual amount of \$1,502,000, which exceeds the City Manager's signature authority.

Task Order 1	Public Works Staff Augmentation	\$600,00 / annually
Task Order 2	Community Development Staff Augmentation	\$210,000/ annually
Task Order 3	Plan Check Services	\$692,000/ annually

FISCAL IMPACT:

Staff recommends funding the proposed Public Works Staff Augmentation (Task Order 1) with the Capital Improvement Plan budget (60%) and salary savings (40%). Funding for Community Development staff (Task Order 2) would come from salary savings resulting from ongoing vacancies in the department. An additional appropriation of \$237,000 from the General Fund is needed to cover the costs for Plan Check services (Task Order 3).

Respectfully submitted by:



Shawn Igoe
Director of Public Works



Steven Sizemore
Interim Director of Community Development

Reviewed by:



Martha Garcia
Director of Management Services

Approved by:



Ron Bow
City Manager

Reviewed by:

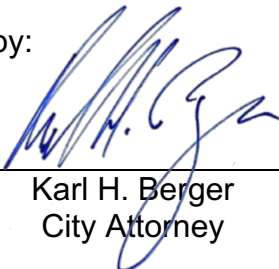

Karl H. Berger
City Attorney

ATTACHMENTS:

1. Transtech Rate Sheet
2. Transtech Proposal Letters

ATTACHMENT 1

Transtech Rate Sheet

TRANSTECH ENGINEERS, INC.
SCHEDULE OF HOURLY RATES
Effective through June 30, 2023

City of Monterey Park

ENGINEERING	
Field Technician	\$86
Engineering Technician	\$102
Assistant CAD Drafter	\$124
Senior CAD Drafter	\$145
Associate Designer	\$150
Senior Designer	\$161
Design Project Manager	\$199
Assistant Engineer	\$129
Staff/Associate Civil Engineer	\$156
Senior Civil Engineer	\$209
Traffic Analyst Technician	\$118
Associate Traffic Analyst	\$140
Senior Traffic Analyst	\$161
Professional Transportation Planner	\$177
Traffic Engineer Technician	\$102
Associate Traffic Engineer	\$156
Traffic Engineer	\$177
Senior Traffic Engineer	\$199
Project Manager	\$183
Senior Project Manager	\$199
Deputy City Engineer	\$172
City Engineer	\$188
Principal Engineer	\$209

CONSTRUCTION MANAGEMENT	
Labor Compliance Analyst	\$145
Funds Coordinator	\$150
Utility Coordinator	\$161
Office Engineer	\$145
Construction Inspector	\$145
Senior Construction Inspector	\$156
Construction Manager	\$199
Resident Engineer	\$199
PUBLIC WORKS INSPECTION	
Public Works Inspector	\$145
Senior Public Works Inspector	\$156
Supervising PW Inspector	\$161
SURVEY AND MAPPING	
Survey Analyst	\$145
Senior Survey Analyst	\$156
2-Man Survey Crew	\$333
Survey & Mapping Specialist	\$188
Licensed Land Surveyor	\$204
FUNDING & GRANT WRITING	
Funds Analyst	\$140
Senior Funds Analyst	\$150
Graphic & Rendering Designer	\$134
Grant Writer	\$166
Funds & Grant Project Manager	\$188

BUILDING & SAFETY	
Permit Technician	\$91
Building Inspector	\$97
Senior Building Inspector	\$118
Plans Examiner/Checker	\$134
Plan Check Engineer	\$145
CASp Plan Checker	\$161
Deputy Building Official	\$161
Building Official	\$172
PLANNING	
Community Development Technician	\$86
Planning Technician	\$91
Assistant Planner	\$129
Associate Planner	\$145
Senior Planner	\$166
Planning Manager	\$177
ADMINISTRATIVE STAFF	
Administrative/Clerical	\$70
Project Accountant	\$86

CPI-U FEBRUARY 2022

7.40%

All fees are increased each year July 1st automatically by the percentage change Los Angeles-Long Beach-Anaheim California Consumer Price Index- All Urban Consumers ("CPI-U") for the preceding twelve-month period as calculated for February by the U.S. Department of Labor Bureau of Labor Statistics and published by the United States Bureau of Labor Statistic.

ATTACHMENT 2

Transtech - Proposal Letters



October 19, 2022

City of Monterey Park
Steve Sizemore
Interim Director of Community and Economic Development
ssizemore@montereypark.ca.gov

Subject: **BUILDING AND SAFETY PLAN CHECK SERVICES**

Dear Steve:

Per City’s request, Transtech is pleased to submit this proposal to provide **BUILDING AND SAFETY PLAN CHECK SERVICES** to the City.

Per our discussion, it is our understanding that the city is looking for as needed Building and Safety plan check services. The fees for the services are as the following:

Services	Fees
Plan Check On a need basis	50% of the plan check fees as per City Fee Schedule
Where no fees collected for plan check or permits, entitlement reviews, LID Compliance, Soils Report, Hydrology Report Reviews and other additional services requested shall be per the hourly standard rate of \$120/hr.	
Schedule of hourly rates and any hourly fees will be increased each year July 1 st automatically by the percentage change Los Angeles-Long Beach-Anaheim California Consumer Price Index-All Urban Consumers (“CPI-U”) for the preceding twelve-month period as calculated for February by the U.S. Department of Labor Bureau of Labor Statistics and published by the United States Bureau of Labor Statistic.	

Should you have any questions, or require additional information, please contact us.

Dennis Tarango, CBO, Principal Building Official
E: dennis.tarango@transtech.org
C: 909-821-7117, O: 909-595-8599;127

Ayla Jefferson, CBO, Principal Building Official
E: ayla.jefferson@transtech.org
C: 909-851-5765, O: 909-595-8599;123



October 19, 2022

City of Monterey Park
Steve Sizemore
Interim Director of Community and Economic Development
ssizemore@montereypark.ca.gov

Subject: **BUILDING AND SAFETY DIVISION STAFF AUGMENTATION SERVICES**

Dear Steve:

Per City’s request, Transtech is pleased to submit this proposal to provide **BUILDING AND SAFETY DIVISION STAFF AUGMENTATION SERVICES** to the City.

Per our discussion, it is our understanding that the City is looking for an as needed Building Official and full time Building Inspector until the vacant City Building Inspector position is filled. Currently Transtech is providing approximately 8-10 hrs. a week Building Official staff support and 40 hrs. a week Building Inspector staff support. The fees for the services are as the following:

Services	Fees
Building Official Services 8 to 10 hrs. /week	\$140
Building Inspector at a special rate *	\$65
Schedule of hourly rates and any hourly fees will be increased each year July 1 st automatically by the percentage change Los Angeles-Long Beach-Anaheim California Consumer Price Index-All Urban Consumers (“CPI-U”) for the preceding twelve-month period as calculated for February by the U.S. Department of Labor Bureau of Labor Statistics and published by the United States Bureau of Labor Statistic.	
*Special rate for Building Inspector will be valid until position filled. Hourly rate will be increased each year July 1 st automatically by the percentage change Los Angeles-Long Beach-Anaheim California Consumer Price Index-All Urban Consumers (“CPI-U”) for the preceding twelve-month period as calculated for February by the U.S. Department of Labor Bureau of Labor Statistics and published by the United States Bureau of Labor Statistic.	

Please see attached Transtech SOQ

Should you have any questions, or require additional information, please contact us.

Dennis Tarango, CBO, Principal Building Official
E: dennis.tarango@transtech.org
C: 909-821-7117, O: 909-595-8599;127

Ayla Jefferson, CBO, Principal Building Official
E: ayla.jefferson@transtech.org
C: 909-851-5765, O: 909-595-8599;123

TRANSTECH STATEMENT OF QUALIFICATIONS

January 2022



Transtech Engineers, Inc.

Transtech.org

info@transtech.org

855.595.2495 (toll-free)

ISO 9001 Certified



STATEMENT OF QUALIFICATIONS

Transtech Engineers, Inc.

January 2022

ABOUT TRANSTECH

Company Profile: Established in 1989, Transtech (a California Corporation) is a multi-disciplinary engineering consulting firm. Transtech is currently providing municipal services over 65 agencies, and has extensive experience providing services to public sector clients and working in a mixed public agency staff/consultant environment for over 32 years. Our staff and resources include, civil engineers, city engineers, traffic engineers, building officials, project managers, designers, plan checkers, inspectors, construction managers, traffic and transportation analysts, technicians, planners, support personnel. Our key staff members serve as Public Works Directors, City Engineers, Building Officials for Public Agencies. Our resources include approximately 150 team members.

Service Capabilities:

- City Engineer, City Traffic Engineer, Development Review, Public Works Engineering, Plan Check, Inspection
- Civil Engineering
- Staff Augmentation
- CIP Program Management
- Construction Management and Inspection
- Federally Funded Project Management
- Grant Writing
- CDBG Project Management
- Building & Safety Services, Building Inspection, Plan Check, Building Evaluations, City Building Official, Code Enforcement
- Labor Compliance
- Planning Support
- Traffic and Transportation Planning and Engineering
- Water Resources Engineering
- Surveying, Mapping, ALTA, Right-of-way Engineering
- Emergency, Support Services

Dedication and commitment to serve public sector clients: Transtech is currently providing municipal services to over 65 public agencies. We have extensive experience providing services to public sector clients and working in a mixed public agency staff/consultant environment for over 32 years. We consider our staff as extension of City staff, and work in the same structure and

hierarchy as other City staff, and coordinate and interact with various City staff members.

One of the unique qualifications of Transtech is that we serve a number of public agencies as municipal contract service providers. **We serve as Contract City Engineer, City Traffic Engineer, CIP Manager, PW Director, Building Official, Building Inspector, Plans Examiner/Plan Checker, Permit Technician, Public Works Inspector, Construction Manager, Construction Inspector, Designer, Federally Funded Project Manager and in other capacities for a number of public agencies.**

Transtech is currently providing municipal services to over 65 agencies:

Transtech Engineers, Inc. Proudly Services

<ul style="list-style-type: none"> ✓ Municipal Engineering & Public Works Consulting ✓ Building & Safety Plan Check & Inspection ✓ Construction Management Project & Program Management 	<ul style="list-style-type: none"> ✓ Civil Engineering Design ✓ Engineering Plan Check Public Works Inspection ✓ Traffic & Transportation Engineering 	<ul style="list-style-type: none"> ✓ Grant Writing Funds Management ✓ Planning ✓ Mapping & Right-of-Way Engineering 	<ul style="list-style-type: none"> ✓ Surveying ✓ Land & Real Estate Development ✓ Community Outreach Public Relations
--	--	--	--

TRANSTECH
Est. 1989
Transtech Engineers, Inc.
Transtech.org
info@transtech.org
855.595.2495 (toll-free)
ISO 9001 Certified
Better Business Bureau Accredited A+ Rating

City of Temple City

- ✓ **City Engineering Services:** City Eng, Traffic Eng, Development/Public Works Plan Check, Map and Plan Check, Permit Inspection, Design, CIP and Construction Management, PW Insp, Fed Proj Management
- ✓ **Building & Safety Services:** Building Official, Plan Review, Inspection, Permit Technician

City of Commerce

- ✓ **City Engineering Services:** City Eng, Traffic Eng, Development/Public Works Plan Check, Map and Plan Check, Permit Inspection, Design, CIP and Construction Management, PW Insp, Fed Proj Management
- ✓ **Building & Safety Services:** Building Official, Plan Review, Inspection, Permit Tech

City of Alhambra

- ✓ **City Engineering Services:** City Eng, Traffic Eng, Development/Public Works Plan Check, Map and Plan Check, Permit Inspection, Design, CIP and Construction Management, PW Insp, Fed Proj Management
- ✓ **Building & Safety Services:** Building Official, Plan Review, Inspection, Permit Technician

City of South El Monte

- ✓ **City Engineering Services:** City Eng, Traffic Eng, Development/Public Works Plan Check, Map and Plan Check, Permit Inspection, Design, CIP and Construction Management, PW Insp, Fed Proj Management
- ✓ **Building & Safety Services:** Building Official, Plan Review, As-needed Inspection, As-Needed Permit

City of Big Bear Lake

- ✓ **Building & Safety Services:** Building Plan Review
- ✓ **City Engineering Services:** City Eng, Traffic Eng, Development/Public Works Plan Check, Map and Plan Check, Design, CIP and Construction Management, PW PC/Insp, Fed Proj Management

City of Maywood

- ✓ **City Engineering Services:** City Eng, Traffic Eng, Development/Public Works Plan Check, Map and Plan Check, Permit Inspection, Design, CIP and Construction Management, PW Insp, Fed Proj Management

City of Chino

- ✓ **CIP Management Services:** Transtech is City's Contract CIP Manager for major Public Works Projects.

City of Ontario

- ✓ **CIP Management Services:** Transtech is City's Contract CIP Manager for major Public Works Projects.

City of Monterey Park

- ✓ **Engineering Services/CIP Management:** Engineering Support, Traffic Engineering, CIP Management, PW Plan Check
- ✓ **Building & Safety Services:** Building Official, plan check and as-needed inspection

Bear Valley Community Services District

- ✓ **District Engineering Services/CIP Management:** Engineering Support, Traffic Engineering, CIP Management,

City of South Pasadena

- ✓ **Building & Safety Services:** Building Official, Plan Review, Inspection, Permit Tech

City of Seal Beach

- ✓ **Building & Safety Services:** Building Official, Plan Review, As-needed Inspection

City of Azusa

- ✓ **Building & Safety Services:** Building Plan Review, As-needed Insp

San Manuel Indian Reservation

- ✓ **Building & Safety Services:** Building Official, Plan Review, Inspection

San Manuel Casino

- ✓ **Building & Safety Services:** Building Official, Plan Review, Inspection

City of Placentia

- ✓ **On-call PM/CM and Development/PW Plan Check:** On-call services.

City of San Clemente

- ✓ **On-call Services:** Development/Public Works Plan Check

Technician

City of West Covina

- ✓ **City Engineering Services:** City Eng, Traffic Eng, Development/Public Works Plan Check, Map and Plan Check, Permit Inspection, Design, CIP and Construction Management, PW PC, Fed Proj Management
- ✓ **Building & Safety Services:** Building Official, Plan Review, Inspection, Permit Technician

City of Rosemead

- ✓ **City Engineering Services:** City Eng, Traffic Eng, Development/Public Works Plan Check, Map and Plan Check, Permit Inspection, Design, CIP and Construction Management, PW Insp, Fed Proj Management

City of Pico Rivera

- ✓ **City Engineering and CIP Management Services:** City Engineer and CIP Management.

City of Bell

- ✓ **Building & Safety Services:** Building Official, Plan Review, Inspection, Permit Technician

City of Hawaiian Gardens

- ✓ **Building and Safety Services:** Building Official, Plan Review, Inspection, Permit Technician

City of Downey

- ✓ **Building & Safety Services:** Plan Review, Inspection

County of Riverside

- ✓ **Building & Safety Services:** Plan Review, Inspection

San Bernardino County Housing Authority

- ✓ **On-call Services:** As-Needed Support

City of San Bernardino

- ✓ **On-call Services:** Traffic Engineering, Constr. Management.

City of Moreno Valley

- ✓ **Building & Safety Services:** Plan Review, Inspection

UTC Corporation/City of Riverside

- ✓ **Building & Safety Services:** Plan Review, Inspection, and Support

City of El Monte

- ✓ **On-call Services:** Engineering Support, Traffic Engineering, Construction Management, Development/Public Works Plan Check, Map and Plan Check.

County of Los Angeles

- ✓ **Building & Safety Services:** Plan Review, Inspection

City of Norwalk

- ✓ **Building & Safety Services:** Plan Review

City of San Marino

- ✓ **City Traffic Engineering Services:** City Traffic Engineering

City of Hermosa Beach

- ✓ **Plan Check Services:** Dev Plan Check

City of Rialto

- ✓ **On-call Services:** PW Permit Inspection Services.

City of Culver City

- ✓ **On-call Engineering Services:** Eng Services

City of Santa Ana

- ✓ **On-call Services:** Eng and Tech Support Services

City of Chino Hills

- ✓ **On-call Services:** Engineering

City of Anaheim

- ✓ **Engineering Services:** Engineering Services

City of Pasadena

- ✓ **On-call Engineering Services:** Engineering Services

City of Yorba Linda

- ✓ **Traffic Engineering Services:** On-call Traffic Engineering

City of Banning

- ✓ **Public Works Plan Check:** PW Plan Check and Pw Inspection

Riverside County Economic Development Agency

- ✓ **On-call Services:** Eng, Building Evaluations, & Surveying

City of Lancaster

- ✓ **Traffic Engineering Services:** On-call City Traffic Engineering

City of Palm Desert

- ✓ **City Traffic Engineering Services:** City Traffic Engineering

City of Irwindale

- ✓ **On-call Services:** Construction Management and Inspection Services.

City of Lynwood

- ✓ **On-call Services:** Engineering, Construction Management

Transtech Team Licenses and Certificates in Diversified Fields:

- Professional Licensed Engineer (PE, SE, ME, EE)
- Professional Licensed Traffic Engineer (TE)
- Professional Licensed Land Surveyor (PLS)
- Professional Transportation Planner (PTP)
- Licensed General Contractor A and B
- Qualified Storm Water Pollution Prevention Plan Developer (QSD)
- Qualified Storm Water Pollution Prevention Plan Practitioner (QSP)
- General Permit Qualified Industrial Stormwater Practitioner (QISP)
- ICC Certified Building Official
- ICC Certified Building Code Official
- ICC Certified Sustainability Professional
- ICC Certified Building, Electrical, Mechanical & Plumbing Electrical Plans Examiner
- ICC Certified Commercial Building, Electrical, Mechanical & Plumbing Inspector
- ICC Certified Residential Building, Electrical, Mechanical & Plumbing Inspector
- ICC Certified Combination Inspector
- ICC Certified Fire Plans Examiner
- ICC Certified Permit Technician
- ICC Certified CalGreen - CA Green Building Plan Examiner
- ICC Certified CalGreen - CA Green Building Inspector
- ICC Certified CA Residential Mechanical Inspector
- ICC Certified Plumbing Inspector UPC ICC Certified CA Commercial and Res Plumbing Inspector
- ICC Certified Accessibility Plans Examiner
- ICC Certified Accessibility Inspector
- CASp, California Access Specialist
- IAPMO Certified CA Residential Mechanical Inspector

Our team members are involved in many local and national ICC and CALBO committees, and are involved in the development of local and national guidelines and codes:

- Chair; ICC Sustainability Membership Council
- Chair; ICC LA Chapter Inspection Committee
- Commissioner; ICC Codes & Standards
- ICC Los Angeles Basin Chapter Board of Directors
- ICC Building Officials Membership Governing Council
- ICC Code Development Committee Vice Chair
- ICC Technology/Web Advisory Group

- Council
- Commissioner; CALBO Green Committee
- Commissioner; ICC/CALBO CA Exam Committee
- Commissioner; CALBO Outreach/Communications Committee
- IAS Accreditation Committee
- ICC LA Chapter Accessibility Committee
- Commissioner; CALBO State Licensing Boards Committee

Experience in Federally Funded Projects: We have extensive experience in the management and administration of federally funded projects. Our staff members have completed Caltrans Resident Engineer Academy for Federally Funded Projects. We follow guidelines and procedures of Caltrans Local Assistance Procedures Manual (LAPM).

Experience in Grants: Our team has proven track record in obtaining outside grants for its client cities. Our staff works with our client cities to find potential funding sources, and to prepare competitive applications for various programs. We have obtained extensive amount of funds for our client cities. Additionally, after funds are awarded to a client, our experienced staff provides assistance to ensure compliance with applicable funding program requirements, including preparing necessary clearance approvals (environmental, utilities, ROW), processing E-76 authorizations, and managing project.

Experience with CALTRANS: Our team includes experienced staff members who have worked for CALTRANS and are intimately familiar with the standards and procedures, project development and approval process, and requirements.

Technology: Transtech has integrated many technological assets into its services to provide most efficient and cost-effective service. We provide fully automated electronic plan submittal, checking and tracking. We provide this on our company portal, as well as offer same portal to our client cities on their web sites. As a result of recent impacts of Novel Covid-19 pandemic, we have also implemented issuance of permits for certain types of projects thru complete on-line submittal and review, and without direct face-to-face interaction with applicants. We have provided toll free numbers, video conference call with applicants to discuss any questions and review plans on common screens as necessary, set-up electronic/credit card payment options, and issued permits on-line.

- **Electronic Plan Check:** Transtech provides Electronic Plan Check. [Click here](#) for a sample of our electronic plan check portal at one of our contract Cities.
- **Virtual Counter:** We offer virtual meetings with plan checkers. To explore the virtual Plan Check Counter appointment calendar at one of our contract Cities, [click here](#).

Readily Available Staff: Transtech has a large pool of well experienced in-house staff readily available to provide requested services, and respond to specific projects schedules in a timely, efficient and cost effective manner.

Transtech's "Customer Care" and "Methodology" Approach in delivering the services in an efficient, cost effective, and timely manner:

- Our services are founded on the principals of **Total Quality Management** for **Total Customer Care**.
- We have a **structured approach** to execute projects in an efficient manner that makes

Transtech capable of providing the City with the highest quality product. Transtech has established guidelines and policies, including written manuals on quality control, project management, and design procedures for its staff and for its contract cities. These guidelines ensure a consistent approach to the execution of assignments undertaken by our organization in compliance with Client's specific procedures, standards and requirements.

- We start by **working with the applicant early on** and during plan review to help the applicant prepare a set of plans which have all the required information clearly and logically presented.
- Transtech provides all plan check **comments on electronic files**. All plan check comments are provided on scanned pdf format electronically, **as well as hard copies**. Plan review corrections are written clearly and are **fully detailed to explain the Code deficiency** (including all applicable code sections).
- To help the applicant better understand the problem, Transtech provides as much information during plan review as possible. We believe that if the applicant has a **clear understanding of the problem**, the applicant can take the necessary steps to correct the condition. This policy reduces the number of plan review rechecks required, allows the applicant to **obtain a permit much sooner**, and reduces the overall time our staff is required to spend on that particular plan. Unclear and/or cryptic corrections are never written, and all correction lists, except those written over-the-counter, are typed and printed on a laser printer.
- Our plan checkers **confer early on and respond to questions** from the applicant, etc.
- Our policy is to assist the applicant as much as possible, which helps **eliminate complicated details, reduce construction costs, and/or provide details which are easy to verify in the field**.
- All telephone calls or e-mails received are returned within same working day, or the following day. We take pride in our "**Same Day Response**" motto.
- **Responsiveness is an integral part** of Transtech's "customer friendly" service approach.
- Our Contract Principal **meets with the Client's Project Manager regularly** to **monitor the service quality** and address any areas for improvements.

Community and Local Business Support: Transtech is an active supporter of Cities and Local Businesses where we serve. During Covid-19 Pandemic, we have arranged delivery of lunches to local police and fire departments in appreciation of front lone workers and made all purchases from local restaurants.

Community Benefit Enhancement: Supporting civic and community activities demonstrates Transtech's commitment to the progress, health, and well-being of the communities we serve. This is something that we take pride in as a company. In services and partnership with our client cities, we have a proven record of active engagement in City and Community events. This could include involvement or presence at City programs or events, supporting local businesses through the chamber, youth events, hosting workshops, sports, scholarship opportunities, community service, managing homelessness challenges, public safety, crime prevention, or any other community benefit that the City wishes us to be a part of. Our goal is not just to serve as an engineering consultant which is what we are best at, but also in being an active partner with our clients, to further enhance the City's reputation as an ideal community to live, invest, work, and play in. We are deeply committed to maintaining our partnership with our valued customers, its community, and remain open and enthusiastic to receiving input on how to best serve the City's needs today

and in the future to further enhance the City's reputation as an ideal community to live, invest, work, and play in.

COVID-19: Our staffing structure and organization is re-envisioned for the greatest responsiveness in a conveniently and easily accessible manner to City, residents, development community and public. We worked with our client cities to transform "in-person" services to a fully integrated virtual meetings during the recent closures of City Halls due to COVID-19. We are excited to share that the transition has been a success across the many departments and divisions we serve in Building & Safety, Engineering, Public Works, Community Development, and Planning.

Transtech Engineers, Inc. was highlighted in the recently published APWA Southern California Chapter's Insight Magazine detailing our development of virtual solutions for municipal agencies during the "new normal". You may see the 2 articles published from links below.

- **Article 1** - Article detailing Transtech's virtual solutions during the pandemic and our response to COVID, several of our client cities have already implemented with great success (starting on page 6 of magazine): <https://apwasocal.partica.online/apwa-social-insight/socal-insight-2020-issue-1/flipbook/6/>
- **Article 2** - Article detailing our virtual community engagement approach for Public Works Projects during COVID (starting on page 8 of magazine): <https://apwasocal.partica.online/apwa-social-insight/socal-insight-2020-issue-2/flipbook/8/>

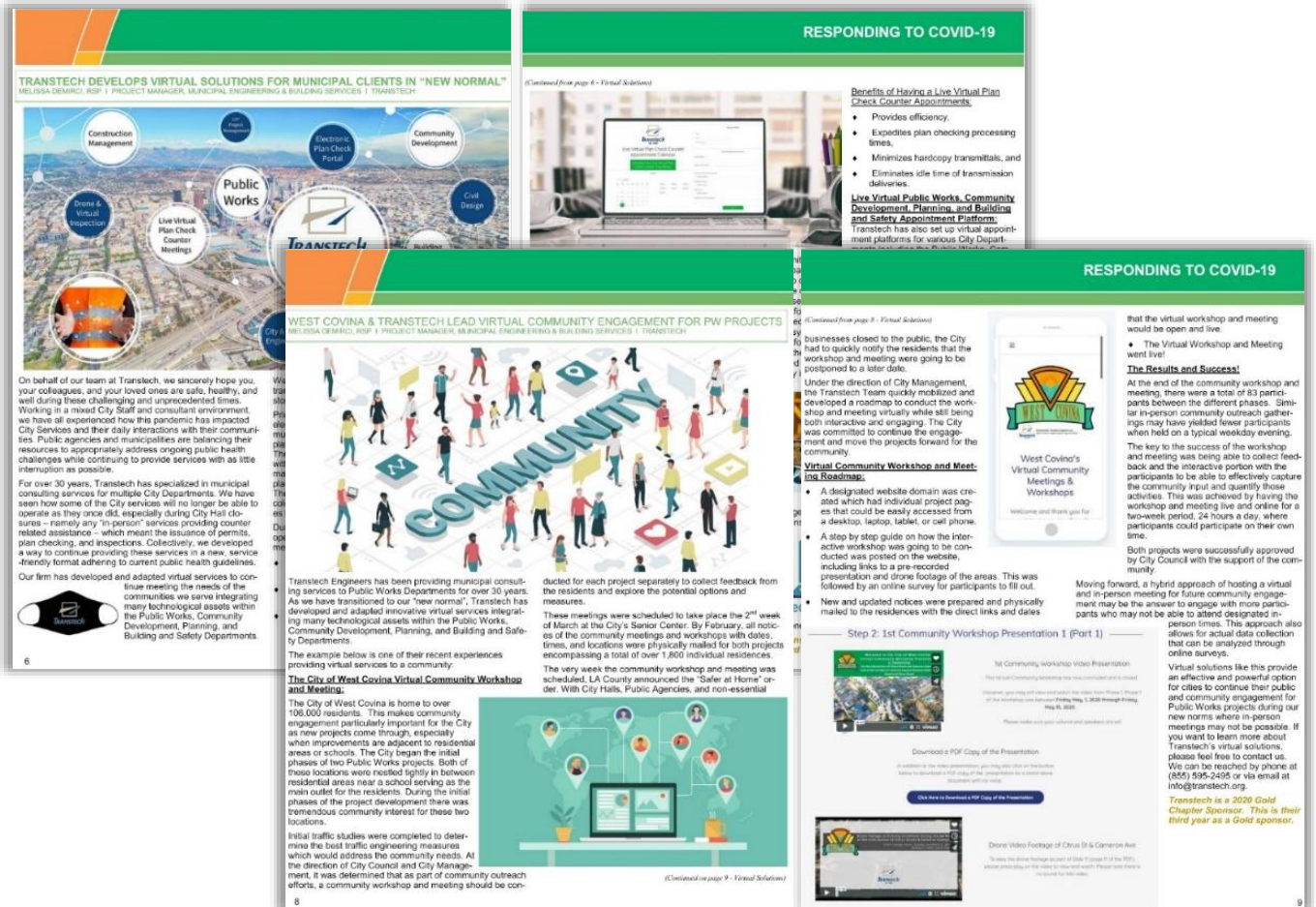

PROJECT EXAMPLES REPRESENTATIVE OF TRANSTECH'S DIVERSIFIED EXPERIENCE

ROADWAY/INFRASTRUCTURE PROJECTS



Washington Boulevard Widening and Reconstruction Project (\$40M): Transtech provided CM/CI/Resident Engineer, Inspector, Office Engineer Services. The project included widening and reconstruction of 2.7 miles of Roadway, Traffic Signals, Street Lighting, Landscape, Improvements at I-5 & at 710 Freeways ramps. The project was federally funded and was managed in compliance with Caltrans Local Assistance Procedures Manual. The project was also a Caltrans Oversight Project.

AWARD: This project was recognized as one of the projects of the year as part of the 2017 American Public Works Association (APWA) BEST Award, in the category of Transportation Projects.



Rosemead Boulevard Improvements Project (\$20M): Located in the City of Temple City, this was a Federally Funded project. Funding included METRO Measure R & Prop C Funds. Transtech provided Project, Program, Construction Management, Resident Engineer, Inspection, Federal Compliance, Labor Compliance & Office Engineer Services. The project included protected bike lanes, widening & reconstruction of 2 miles of roadway.

AWARD: The project has achieved numerous awards including a 2013 Planning Excellence in Implementation Award from the American Planning Association, the 2014 Quality of Life Merit Award from the American Society of Landscape Architects, the 2014 Merit Award for Urban Design from the California Council of the AIA & was voted one of the "best 10 new bike lanes of 2014" from the PeopleforBikes organization.



Atlantic Boulevard Corridor Improvement Project (\$20M): This was a Federally Funded project in the City of Commerce. Transtech provided turnkey services included construction management, resident engineer, inspection, office engineer, & funds coordinator. The project was a major street reconstruction & beautification project along Atlantic Boulevard which improved mobility for pedestrians, trucks, & vehicles as well as provided corridor beautification with landscaped medians and other elements.

AWARD: This project was recognized as one of the projects of the years as part of the 2020 American Public Works Association (APWA) Project of the Year Award, in the category of Transportation Projects.



Cactus Avenue and Nason Street Improvements and 135' Span Bridge Project (\$21M): This project was part of the State Local Partnership Program SLPP Grant in the City of Moreno Valley (\$21M). Transtech provided construction management, resident engineer, inspection, & office engineer services.

AWARD: This project was recognized with a project achievement award by the Construction Management Association of America (CMAA) for Construction Management Services under the Public Works Category for \$11M-\$50M ranged projects.

BUILDING PROJECTS



City of Alhambra Civic Center Library Project (\$25M): The project involved construction of a 45,000 SF Library with multi-level underground parking garage. The project was delivered as DBB. Transtech served as Owner Representative and Program Manager from initial project planning, design development thru construction. Transtech also provided building code plan check, constructability, biddability and value engineering review. Also, during construction, Transtech provided construction management and inspection services. This project is located in Alhambra.



Mosaic Parking Structure DB (Design-Build) Project (\$6M): The project involved construction of a 5 story parking structure. The project was delivered as DB. Transtech served as Owner Representative and Program Manager from initial project planning, design development thru construction. Transtech also provided building code plan check, constructability, biddability and value engineering review. Also, during construction, Transtech provided construction management and inspection services. This project is located in Alhambra.



C Block Parking Structure DB (Design-Build) Project (\$15M): This project is being delivered under DB delivery method. Transtech is City's Owner's Representative/Program Manager. Currently, the project is under construction. Transtech also prepared DB Pre-Qualification and RFP Packages, including preparation of Bridging Documents. For the Bridging Documents, Transtech retained parking structure architect, soils engineer and other specialty consultants for the preparation of Technical Bridging Documents/Plans. Transtech served as Owner's Representative/Program Manager and Construction Manager.



Ontario Great Park Phase 1 Project DB (Design-Build Project. (\$75M): This project is being delivered under DB delivery method. Transtech is City's Owner's Representative/Program Manager. Transtech is currently preparing DB Documents, which include Bridging Documents, Pre-Qualification Package and RFP Package for the selection of DB Entity. Following are preliminary concepts developed by the architect, which as provided as idea reference, and shall not be construed as approved concepts by the City of Ontario.



Renaissance Plaza (\$15M): The project involved construction of a 5-story parking structure, 10 plex movie theater, retail, and plaza. The project was delivered as DBB. Transtech served as Owner Representative and Program Manager from initial project planning, design development thru construction. Transtech also provided building code plan check, constructability, biddability and value engineering review. Also, during construction, Transtech provided construction management and inspection services. This project is located in Alhambra.



Rosewood Community Center (\$25M): The project involved construction of a Community Center with Olympic regulation swimming pool for competition. The project was delivered as DBB. Transtech was retained by the City of Commerce to take over the management of this multimillion-dollar facility which was 2 years behind schedule. Within 5 months, Transtech brought the construction to substantial completion level allowing the City to start the move-in process, and 2 months after, the facility was opened for public use. This project is located in Alhambra.



City of San Bernardino Santa Fe Depot/Metrolink Parking Structure and Historic Santa Fe Depot Renovation Project (\$25M): The project involved construction Historic Santa Fe Depot Renovation for adoptive reuse of 60,000 sf Historic Santa Fe Train Depot, and later a 3-level parking structure. The project was delivered as DBB. Transtech served as Owner Representative and Program Manager from initial project planning, design development thru construction. Transtech also provided building code plan check, constructability, biddability and value engineering review. Also, during construction, Transtech provided construction management and inspection services. This project is located in San Bernardino.

BUILDING AND SAFETY PROJECTS



Agency: City of Temple City, Project: Blossom Walk Residential Development (Valuation \$6M): This development includes 24-unit condominiums and 4 single family homes.

Transtech provided following services:

- Establishing conditions of approval and coordination with the Planning Staff for the entitlement of the project.
- Building Plan Check and inspection.
- Plan check for Map, Utilities, Off-site Improvements and Public Works Inspection.

Transtech serves as the City's Contract Building Official, City Engineer, City Traffic Engineer



Agency: City of South El Monte, Project: Chico Residential Development (Valuation \$15M): This development includes 13 buildings with 70 residential units.

Transtech provided following services:

- Establishing conditions of approval and coordination with the Planning Staff for the entitlement of the project.
- Building Plan Check.
- Engineering Plan Check to include plan check for Map, Utilities, Off-Site improvements and inspections.

Transtech serves as the City's Contract Building Official, City Engineer, City Traffic Engineer



Agency: City of Commerce, Project: Warehouse with Office Space Development (Valuation \$20M): This development includes one-story of warehouse with mezzanines for office use of 114,898 square feet of total floor area in a 5.65-acre lot.

Transtech provided following services:

- Establishing conditions of approval and coordination with the Planning Staff for the entitlement of the project.
- Building Plan Check and inspection.
- Plan check for Map, Utilities, Off-site Improvements and Public Works Inspection.

Transtech serves as the City's Contract Building Official, City Engineer, City Traffic Engineer



Agency: City of Alhambra, Project: Main Street Collection (Valuation \$23M): This development includes 4-story mixed-use project with 8,200 s ft retail space, 52 condos, 9 live/work units, 19 townhomes, and 6 shopkeeper units.

Transtech provided following services:

- Establishing conditions of approval and coordination with the Planning Staff for the entitlement of the project.
- Building Plan Check.
- Engineering Plan Check to include plan check for Map, Utilities, Off-Site improvements and inspections.

Transtech serves as the City's Contract Building Official, City Engineer, City Traffic Engineer



Agency: City of West Covina, Project: Medical Center Building (valuation \$20M): This project is a new Medical Office Building of approximately 55,000 sf that will operate 24/7 providing a radiation oncology department and infusion department.

Transtech provided following services:

- Establishing conditions of approval and coordination with the Planning Staff for the entitlement of the project.
- Building Plan Check.
- Engineering Plan Check to include plan check for Map, Utilities, Off-Site improvements and inspections.

Transtech serves as the City's Contract Building Official, City Engineer, City Traffic Engineer



San Manuel Band of Mission Indians-Building and Safety, Plan Check, Inspection Services for Casino Expansion/Development Project (\$700M): Transtech serves as the Building Official, Plan Checker and Inspector for the Tribe. Currently we are providing Plan Check and Inspection services for Casino's expansion program, which includes casino renovation, hotel, entertainment center, parking structure, pedestrian bridges, alignment of entry and exit roads, and various other improvements.

PARK PROJECTS



Lugo Park, Soccer Field (synthetic turf) and Park Improvements Project (\$2M): This project was partially funded through CDBG funds in the City of Cudahy. The project included constructing a new soccer field with artificial turf on existing baseball field, landscaping, parking lot, concrete plaza, lighting, drainage, ADA improvements.



Manhattan Village Park, Soccer Field (synthetic turf) Improvements Project (\$1M): The project included replacement of existing turf with a new artificial turf, site fencing and landscaping improvements.



Salt Lake Park Splash Pad Project (\$1M): This project included installation of splash park.



Garvey Ranch Basketball Court Improvements (\$500K): This project included construction of new PCC basketball court installation, striping, basketball hoops, fence, and PCC walkway in Monterey Park.



Washington Bl Widening and Reconstruction Project (\$30M): The project included widening and reconstruction of 2.7 miles of Roadway, Traffic Signals, Street Lighting, Landscape, Improvements at I-5 and at 710 Freeways ramps. The project was federally funded and was managed in compliance with Caltrans LAPM.



Citywide Parks Improvement Project (\$6.5M): This project included installation of park equipment (playground, picnic shelters, benches), construction of ADA improvements, and various PCC improvements at 13 parks in the City of Monterey Park.



Almansor Park Improvements Project (\$2.5M): This project was at Almansor Park in the City of Alhambra and included construction of new basketball courts, restroom facilities, shade structure, new drainage systems, new lightings, and updated landscaping and irrigation, and PCC walkways.



Temple City Blvd Parking Lot Improvements Projects (\$.5M): This project included new park/parking lot signage, trellis, landscaping, drainage, lighting, electrical vehicle charging station infrastructure for future implementation.



Cascades Waterfall Renovation Project (\$.6M): This project included the renovation of the Cascades Waterfall landmark in Monterey Park, which included lighting, plastering of the fountain, painting, ADA improvements, PCC walkway improvements, and landscaping.



Primrose Park: Transtech is currently managing Primrose Park Project in the City of Temple City, which was designed by DVD. This project is funded by Prop 68 with a cost of \$3M, and is scheduled for completion by February 2021.

KEY STAFF RESUMES

DENNIS TARANGO, CBO, Principal Building & Safety Services. ICC Certified Building Official, Plans Examiner, Inspector



Mr. Tarango has over 20 years of experience in the building and safety division. He is experienced in managing building and safety departments of different municipalities. Currently he is serving as Building Official for Transtech Contract Cities. At Transtech, Mr. Tarango is responsible for the Building and Safety Division as well as business development, client relations, and management oversight. With his analytical and strategic management skills, he provides strong leadership and develops staff to enhance the Departments abilities. Prior to working for Transtech, Mr. Tarango served as Deputy Building Official, Plans Examiner, and Senior Building Inspector for various local cities including the City of Diamond Bar, City of Yorba Linda, and City of Hemet.

EDUCATION

- California State Polytechnic University, Pomona, Engineering
- Fresno State University, Business Administration
- Rio Honda College, General Studies

Mr. Tarango's experience of building and safety operations, comes from working in the capacity of Building Official, Acting Building Official, Deputy Building Official, Plans Examiner and Building Inspector. He has comprehensive knowledge of municipal government operations, including preparation and presentation of staff reports and resolutions to city councils, committees and related interaction with members of the public, other city departments and other governmental agencies. He has extensive experience in construction codes, building and safety plan review and inspection, code interpretations, and resolving code related construction and plan review problems on a broad range of projects.

ICC CERTIFICATIONS

- Certified Building Official
- Building Plans Examiner
- Commercial Building Inspector
- Building Inspector UBC
- Fire Plans Examiner

As Building Official, he provides necessary code interpretation in collaboration with other City Departments and applicants on building and safety related issues. He manages building and zoning code violations with the aid of the City Prosecutor to abate violations. He also provides over the counter plan check as Building Official/Plans Examiner.

HIGHLIGHTS

- Currently on ICC Sustainability Membership Council Governing Committee

As Plans Examiner, he is responsible for examination and approval of architectural and structural plans submitted to municipalities for a wide variety of projects ranging from small residential additions to large, multistory commercial and industrial facilities.

As Building Inspector, he has inspected an array of projects ranging from small residential additions to large complex multifamily, commercial, and industrial facilities. He was also responsible for inspector training and development.

EXPERIENCE IN LARGE COMPLEX PROJECTS (PARTIAL LIST) IN WHICH BUILDING OFFICIAL OVERSIGHT WAS PROVIDED:

- **San Manuel Casino, Refresh Project (\$200M):** This three-year project was a multi-phase remodel of the entire 400,00 SF casino floor including 5 new restaurants, 3 new bars, retail stores, food court, executive offices, chiller plant, bridge, and 50,000 SF of

new gaming area. Transtech provided plan check, inspection, Building Official services.

- **County of Riverside Economic Development Agency, Facility Evaluation:** Located at 41888 Motor Car Pkwy Transtech provided Facility Evaluation Services including an accessibility compliance review to allow the 297,033 SF 5-story office building to operate as an essential services facility.
- **County of Riverside Economic Development Agency, Facility Evaluation:** Located at 450 E. Alessandro Blvd Transtech provided Facility Evaluation Services comprised of a high-level analysis of the structural system and a code compliance evaluation of the entire 5 Acre property including a 16,826 SF office building, outdoor theater, and several assessor structures.
- **Temple City Camellia Square (Project Value: \$15M):** Transtech provided full plan review as well as inspection services, the project included a shopping center with an underground garage and 4 total buildings as follows: a one-story 6,600 SF building; a two-story 25,700 SF building, a two-story 4,500 SF building; and, a two-story 43,400 SF building. This also included Map Check Services, including review of Tentative Parcel Map, Lot Line Adjustment, Perfecting Deed and Final Parcel Map, Off-site Improvements PW Inspection, and Building Inspection Services for this project.
- **Linden Walk Residential Development (Project Value: \$18.5M):** Transtech provided full plan review as well as inspection services for this development which included 74 Single Family Dwellings. This project is located in Temple City. This also included Map Check Services, including review of Tentative Parcel Map, Lot Line Adjustment, Perfecting Deed and Final Parcel Map, Off-site Improvements PW Inspection, and Building Inspection Services for this project.
- **Blossom Walk Residential Development (Project Value: \$5.7M):** Transtech provided full plan review as well as inspection services of for this development which includes 24-unit condominiums and 4 single family homes. This project is located in Temple City. This also included Transtech also provided Map Check Services, including review of Tentative Parcel Map, Lot Line Adjustment, Perfecting Deed and Final Parcel Map, Off-site Improvements PW Inspection, and Building Inspection Services for this project.
- **Pacific Plaza (Project Value: \$30.3M):** Located at 11 S 3rd St (condo) and 300 W Main St (retail). Transtech provided full plan review as well as inspection services of for this development which includes 120 condo units and retail space below. This project is located in Alhambra. This also included Map Check Services, including review of Tentative Parcel Map, Lot Line Adjustment, Perfecting Deed and Final Parcel Map, Off-site Improvements PW Inspection, and Building Inspection Services for this project.
- **The Alhambra (Project Value: \$57.8M):** Located at 88 S Garfield Avenue, 2 S Garfield Avenue, 100 & 150 E Main St. Transtech provided full plan review as well as inspection services of for this development which includes 260 apartment units, 4-story

parking garage, 72,000 sq ft 2-story retail building, 16,730 sq ft 1-story retail building, and 23,000 sq ft 1-story retail building. This project is located in Alhambra. This also included Map Check Services, including review of Tentative Parcel Map, Lot Line Adjustment, Perfecting Deed and Final Parcel Map, Off-site Improvements PW Inspection, and Building Inspection Services for this project.

- **Midwick Collection (Project Value: \$13M):** Located at 2400 S Fremont Avenue. Transtech provided full plan review as well as inspection services of for this development which includes 36 single family dwellings and 28 townhomes. This project is located in Alhambra. This also included Map Check Services, including review of Tentative Parcel Map, Lot Line Adjustment, Perfecting Deed and Final Parcel Map, Off-site Improvements PW Inspection, and Building Inspection Services for this project.
- **Casita de Zen (Project Value: \$21M):** Located at 28 N 3rd St (condo) and 235 W Main St (retail). Transtech provided full plan review as well as inspection services of for this development which includes mixed use project with 92 condos on top, and retail on bottom. This project is located in Alhambra. This also included Map Check Services, including review of Tentative Parcel Map, Lot Line Adjustment, Perfecting Deed and Final Parcel Map, Off-site Improvements PW Inspection, and Building Inspection Services for this project.
- **Main Street Collection (Project Value: \$23M):** Located at 410 W Main Street. Transtech provided full plan review as well as inspection services of for this development which includes 4-story mixed-use project with 8,200 s ft retail space, 52 condos, 9 live/work units, 19 townhomes, and 6 shopkeeper units. This project is located in Alhambra. This also included Map Check Services, including review of Tentative Parcel Map, Lot Line Adjustment, Perfecting Deed and Final Parcel Map, Off-site Improvements PW Inspection, and Building Inspection Services for this project.
- **820 Mission Development LLC (Project Value: \$10M):** Located at 820 Mission St. Transtech provided full plan review as well as inspection services of for this development which includes construction of new office building with one residential unit above, new 15 unit townhome cluster with office fronting Mission Street with one-level subterranean parking, convert existing 3-story industrial building into 9 residential units, construct 13 townhome units. This project is located in South Pasadena.
- **Alta Med Medical Group (Project Value: \$4M):** Located at 1900 E Slauson Ave. Transtech provided full plan review as well as inspection services of for this development which includes a new mixed-use building of office space and an adult day care with new on grade parking. This project is located in Huntington Park. This also included review of Tentative Parcel Map, Lot Line Adjustment, Perfecting Deed and Final Parcel Map, Off-site Improvements PW Inspection, and Building Inspection Services for this project.

AS PART OF THE ROLES AND RESPONSIBILITIES OF A BUILDING OFFICIAL, BELOW IS PARTIAL LIST OF DUTIES AS IT RELATES TO THE ROLE OF CHIEF BUILDING OFFICIAL POSITION:

- Manage multiple Building and Safety Departments and staff and provide any other services as may be necessary for administration and enforcement of the California Building Code and related codes, and applicable provisions of the City's Municipal Code.
- Represent City's as its building official while interfacing with the public and other agencies.
- Respond quickly in the event of a local, regional, or national emergency or disaster, as building official.
- Read, interpret and analyze plans for major structures.
- Visit construction sites and conduct building code inspections when needed as well as conduct job-site evaluations of construction projects for the purpose of monitoring/enforcing compliance with approved plans and code requirements.
- Oversee and participate in the management of a comprehensive building department processes.
- Oversee, direct, and coordinate the work of building staff.
- Participate in the development and administration of the division goals, objectives, and procedures.
- Prepare clear and concise administrative and financial reports as it related to the building department.
- Work with professional architects, engineers, builders, and the general public with a customer service approach.
- Formulate and apply uniform policies and standards for the building inspection programs; formulate, interpret and explain specific building codes, ordinances and administrative orders.
- Research regulations, procedures and/or technical materials relating to building codes and enforcement.
- Represent the City before other agencies and groups on building inspection and enforcement matters.
- Make effective presentations before large and small groups of people.
- Coordinate division services with other programs and services within the County and with outside organizations, and agencies.
- Analyze problems, identify alternative solutions, project consequences of proposed actions and implement recommendations in support of goals.
- Research, analyze, and evaluate new service delivery methods and techniques.
- Interpret and apply federal, state, and local policies, laws, and regulations.
- Communicate clearly and concisely, both orally and in writing.

AYLA JEFFERSON, CBO, CSP Principal Building & Safety Services. ICC Certified Building Official, Plans Examiner, Inspector



Ms. Jefferson has over 25 years of experience in private and governmental sector. She has extensive experience in managing building and safety departments of different municipalities under Transtech contracts. Ms. Jefferson holds over 15 International Code Council issued professional certifications including Certified Building Code Official and 2 IAPMO certifications.

She has served as Building Official, Deputy Building Official, Plan Checker, Code Enforcement Official, Community Improvement Coordinator, Planning Technician, and Inspector for various municipalities. As Building Official, she provides necessary code interpretations, and coordinates with agency staff and departments, and applicants on building and safety related issues. She handles building and zoning code violations as well as working in coordination with the City Prosecutor to abate violations. She also provides over the counter plan check as Deputy Building Official/Plans Examiner. She has broad knowledge of municipal government operations, including preparation and presentation of staff reports and resolutions to city councils, committees and related interaction with members of the public, other city departments and other governmental agencies. She has extensive experience in construction codes, building and safety plan review and inspection, code interpretations, and resolving code related construction and plan review problems on a broad range of projects.

She also coordinates code adoptions for Transtech contract cities. She is involved on various ICC boards, and has served and/or currently serving on a number of ICC Councils, Committees and Boards, locally and nationally. She also served on Calbo Green Committee on State level. She was also appointed as the first national Chair to the ICC Sustainability Membership Council. Ms. Jefferson is responsible for the management of Transtech's Building and Safety Department, and coordination with Transtech's municipal clients. With her analytical and strategic management skills, she provides strong leadership, develops and collaborates with primary contacts to protect and to enhance Transtech's position in specific proceedings; she facilitates and maintains close, long-term working relationships with municipalities in the building and safety realm.

EDUCATION

- Rio Honda College, CE
- Bosphorous Univ, Turkey
- Athanee Royal, Belgium

CERTIFICATIONS

- **ICC Certifications:** Building Code Official, Certified Building Official, Certified Sustainability Professional, Accessibility Inspector, Accessibility Plans Examiner, Building Plans Examiner, California Building Plans Examiner, CalGreen Plans Examiner and Inspector, Building Inspector CBC, Building Inspector UBC, Plumbing Inspector UPC, California Commercial Plumbing Inspector, Residential Mechanical Inspector, California Residential Mechanical Inspector, Permit Technician
- **IAPMO Certifications:** Plumbing, Mechanical Inspector

HIGHLIGHTS

Currently serving as Vice Chair (Past Chair) on ICC Sustainability Membership Council; Currently serving Calbo State Licensing Boards Committee (2019-2021); Served Calbo Community & Outreach Committee; Served ICC/Calbo California Codes Exam Committee; Served on ICC Codes & Standards Council; Served Calbo Green Committee; Chaired ICC Los Angeles Basin Chapter Inspection Committee

EXPERIENCE IN LARGE COMPLEX PROJECTS (PARTIAL LIST) IN WHICH BUILDING OFFICIAL OVERSIGHT WAS PROVIDED:

- **Temple City Camellia Square (Project Value: \$15M):** Transtech provided full plan review as well as inspection services, the project included a shopping center with an underground garage and 4 total buildings as follows: a one-story 6,600 SF building; a two-story 25,700 SF building, a two-story 4,500 SF building; and, a two-story 43,400 SF building. This also included Map Check Services, including review of Tentative Parcel Map, Lot Line Adjustment, Perfecting Deed and Final Parcel Map, Off-site Improvements PW Inspection, and Building Inspection Services for this project.
- **Linden Walk Residential Development (Project Value: \$18.5M):** Transtech provided full plan review as well as inspection services for this development which included 74 Single Family Dwellings. This project is located in Temple City. This also included Map Check Services, including review of Tentative Parcel Map, Lot Line Adjustment, Perfecting Deed and Final Parcel Map, Off-site Improvements PW Inspection, and Building Inspection Services for this project.
- **Blossom Walk Residential Development (Project Value: \$5.7M):** Transtech provided full plan review as well as inspection services of for this development which includes 24-unit condominiums and 4 single family homes. This project is located in Temple City. This also included Transtech also provided Map Check Services, including review of Tentative Parcel Map, Lot Line Adjustment, Perfecting Deed and Final Parcel Map, Off-site Improvements PW Inspection, and Building Inspection Services for this project.
- **Pacific Plaza (Project Value: \$30.3M):** Located at 11 S 3rd St (condo) and 300 W Main St (retail). Transtech provided full plan review as well as inspection services of for this development which includes 120 condo units and retail space below. This project is located in Alhambra. This also included Map Check Services, including review of Tentative Parcel Map, Lot Line Adjustment, Perfecting Deed and Final Parcel Map, Off-site Improvements PW Inspection, and Building Inspection Services for this project.
- **The Alhambra (Project Value: \$57.8M):** Located at 88 S Garfield Avenue, 2 S Garfield Avenue, 100 & 150 E Main St. Transtech provided full plan review as well as inspection services of for this development which includes 260 apartment units, 4-story parking garage, 72,000 sq ft 2-story retail building, 16,730 sq ft 1-story retail building, and 23,000 sq ft 1-story retail building. This project is located in Alhambra. This also included Map Check Services, including review of Tentative Parcel Map, Lot Line Adjustment, Perfecting Deed and Final Parcel Map, Off-site Improvements PW Inspection, and Building Inspection Services for this project.
- **Midwick Collection (Project Value: \$13M):** Located at 2400 S Fremont Avenue. Transtech provided full plan review as well as inspection services of for this development which includes 36 single family dwellings and 28 townhomes. This project is located in Alhambra. This also included Map Check Services, including review of Tentative Parcel Map, Lot Line Adjustment, Perfecting Deed and Final Parcel Map, Off-site Improvements PW Inspection, and Building Inspection Services for this project.
- **Casita de Zen (Project Value: \$21M):** Located at 28 N 3rd St (condo)

and 235 W Main St (retail). Transtech provided full plan review as well as inspection services of for this development which includes mixed use project with 92 condos on top, and retail on bottom. This project is located in Alhambra. This also included Map Check Services, including review of Tentative Parcel Map, Lot Line Adjustment, Perfecting Deed and Final Parcel Map, Off-site Improvements PW Inspection, and Building Inspection Services for this project.

- **Main Street Collection (Project Value: \$23M):** Located at 410 W Main Street. Transtech provided full plan review as well as inspection services of for this development which includes 4-story mixed-use project with 8,200 s ft retail space, 52 condos, 9 live/work units, 19 townhomes, and 6 shopkeeper units. This project is located in Alhambra. This also included Map Check Services, including review of Tentative Parcel Map, Lot Line Adjustment, Perfecting Deed and Final Parcel Map, Off-site Improvements PW Inspection, and Building Inspection Services for this project.
- **City of Alhambra, Civic Center Library Project (\$25M):** Transtech provided plan check, inspection, construction management and owner representative services, the project included construction of a 45,000 SF Library with an underground parking garage.
- **820 Mission Development LLC (Project Value: \$10M):** Located at 820 Mission St. Transtech provided full plan review as well as inspection services of for this development which includes construction of new office building with one residential unit above, new 15 unit townhome cluster with office fronting Mission Street with one-level subterranean parking, convert existing 3-story industrial building into 9 residential units, construct 13 townhome units. This project is located in South Pasadena.
- **Alta Med Medical Group (Project Value: \$4M):** Located at 1900 E Slauson Ave. Transtech provided full plan review as well as inspection services of for this development which includes a new mixed-use building of office space and an adult day care with new on grade parking. This project is located in Huntington Park. This also included review of Tentative Parcel Map, Lot Line Adjustment, Perfecting Deed and Final Parcel Map, Off-site Improvements PW Inspection, and Building Inspection Services for this project.

AS PART OF THE ROLES AND RESPONSIBILITIES OF A BUILDING OFFICIAL, BELOW IS PARTIAL LIST OF DUTIES AS IT RELATES TO THE ROLE OF CHIEF BUILDING OFFICIAL POSITION:

- Manage multiple Building and Safety Departments and staff and provide any other services as may be necessary for administration and enforcement of the California Building Code and related codes, and applicable provisions of the City's Municipal Code.
- Represent City's as its building official while interfacing with the public and other agencies.
- Respond quickly in the event of a local, regional, or national emergency or disaster, as building official.
- Read, interpret and analyze plans for major structures.
- Visit construction sites and conduct building code inspections when needed as well as conduct job-site evaluations of construction

projects for the purpose of monitoring/enforcing compliance with approved plans and code requirements.

- Oversee and participate in the management of a comprehensive building department processes.
- Oversee, direct, and coordinate the work of building staff.
- Participate in the development and administration of the division goals, objectives, and procedures.
- Prepare clear and concise administrative and financial reports as it related to the building department.
- Work with professional architects, engineers, builders, and the general public with a customer service approach.
- Formulate and apply uniform policies and standards for the building inspection programs; formulate, interpret and explain specific building codes, ordinances and administrative orders.
- Research regulations, procedures and/or technical materials relating to building codes and enforcement.
- Represent the City before other agencies and groups on building inspection and enforcement matters.
- Make effective presentations before large and small groups of people.
- Coordinate division services with other programs and services within the County and with outside organizations, and agencies.
- Analyze problems, identify alternative solutions, project consequences of proposed actions and implement recommendations in support of goals.
- Research, analyze, and evaluate new service delivery methods and techniques.
- Interpret and apply federal, state, and local policies, laws, and regulations.
- Communicate clearly and concisely, both orally and in writing.

CRAIG MELICHER, PE, Sr. Engineer



Mr. Melicher has approximately 35 years of experience.

Mr. Melicher has served in various capacities, such as Building Official, City Engineer, and CIP Manager for various Cities. He has extensive experience in construction, California Building Codes, building and safety plan check and inspection, code interpretations, and resolving code related construction and plan check problems on a broad range of residential, commercial and public works capital improvement projects. He has a broad knowledge of municipal government operations, including preparation and presentation of staff reports/resolutions to city councils, committees and interaction with public, various city departments, city council and other governmental agencies.

EDUCATION

- Bachelor of Science in Civil Engineering, CalPoly, Pomona
- Various Construction Management Classes at UCLA, including:
 - Legal Aspects of Construction Management
 - Primavera based Construction Scheduling Software

Mr. Melicher also served as Principal Program Manager for a wide variety of projects. Depending on the specific project, Mr. Melicher's services included everything from initial concept to project close-out. As each project faced its own unique challenges, Mr. Melicher was able to employ his extensive public agency background to insure the most expedition and cost effective solution to each respective challenge, especially where, as Program Manager, Mr. Melicher was specifically responsible for acting on behalf of and insuring the best interests of the project's client. His experience includes serving as Owner's Representative and Construction Manager for large and complex construction projects, such as public works/infrastructure, community center, city hall, library, parking structure, movie theaters, retail centers, etc. He has extensive experience in construction, Green Book, Caltrans Standards, Building Codes.

REGISTRATION

- State of California Registered Civil Engineer

Mr. Melicher has participated in a wide variety of multi-disciplinary development teams responsible for projects that include:

HIGHLIGHTS

- Served as City Engineer and Building Official for 6 Cities.
- Experience in working with State Architect's Office.
- Diversified experience in both Type A (General Engineering) and Type B (Building) projects. Experience in federally funded project management.

- Public Works and Infrastructure Improvements
- Commercial and Retail Developments
- Transportation and Parking Related Facilities
- Residential and Mixed Use Development
- Industrial Development

Some of the significant projects managed by Mr. Melicher include:

- **Riverside County Transportation Commission, Corona Main Street Metrolink Parking Structure and Pedestrian Bridge.** Construction of a 6 level, approximately 1,000 space parking structure that included a pedestrian bridge.
- **City of Alhambra Renaissance Plaza Parking Structure and Entertainment Center.** Construction of a 5 level, approximately 600 space parking structure, a 10-plex movie theater, several retail/restaurant tenant spaces.
- **City of San Bernardino Historic Santa Fe Depot Renovation and Transit Center Parking Structure.** Craig managed the restoration and rehabilitation of the historic San Bernardino Santa Fe Train Depot. The scope included significant hazardous materials abatement, seismic

and other structural upgrades, office tenant improvements, restaurant improvements, installation of new electrical, HVAC, and plumbing systems, and improvements to the adjacent site.

- **TACC Cultural Center Development, Lanham, MD.** Construction of a 310,000 square foot development that included five buildings over an underground parking garage, a Turkish Bath that includes a subterranean swimming pool and basketball court; a cultural center with auditorium and museum space; a fellowship hall with restaurant; a 16 unit apartment building and a large religious facility.
- **City of Commerce Rosewood Community Center Closeout.** Construction of Transtech was retained by the City to take over the closeout as the project had fallen more than two years behind schedule. Craig assisted the City to complete the closeout and help resolve a multi-million dollar delay claim filed by the contractor against the City.
- **Alhambra Redevelopment Agency Downtown Revitalization Program.** Revitalization program that included multiple improvements to the Fremont Plaza that included significant alteration of existing buildings for lease by Toys-R-U's and Party City, construction of a new 30,000 square foot store for PetSmart, and several other stand-alone retail buildings. Significant additional remodel work was also done on multiple buildings on Main Street for various retail and restaurant uses. Mr. Melicher also provide his expertise in the construction field serving as an expert witnesses for construction claims and defects and has a strong background on the legal aspects of project and construction management, and Mr. Melicher is particularly well versed in California statutes regulating all types of publicly funded construction.

Mr. Melicher has a broad knowledge of municipal government operations, including preparation and presentation of staff reports/resolutions to city councils, committees and interaction with public, various city departments, city council and other governmental agencies.

Mr. Melicher also provides training, and establishes procedures for project, construction and program management to local governmental agencies. He lead a team of experts in the preparation of a very extensive Project, Program and Construction Management Procedures Manual for the public agency to assist the department in developing and implementing efficient and state of the art project management practices and procedures to better serve the operational needs of the department, as well as ensuring the delivery of good customer service to its clients.

Mr. Melicher also provided his expertise in the construction field serving as an expert witness for construction claims and defects. He has a strong background on the legal aspects of project and construction management and is particularly well versed in California statutes regulating all types of publicly funded construction.

BILL DORMAN, CBO, CSP, ICC Certified Building Official, Plans Examiner, Inspector

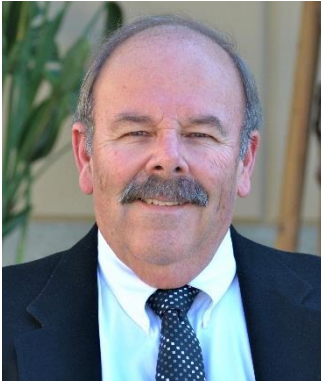

Mr. Dorman has over 30 years of experience in Building and Safety. He serves as Building Official/Plan Checker/Inspector at various Transtech contract cities. He has broad knowledge of municipal government operations, including preparation and presentation of staff reports and resolutions to city councils, committees and related interaction with members of the public, other city departments and other governmental agencies. He has extensive experience in construction codes, building and safety plan review and inspection, code interpretations, and resolving code related construction and plan review problems on a broad range of projects.

EDUCATION

- AS degree – Architecture - East Los Angeles College
- Studied Architecture – Cal Poly – Pomona
- Studied Civil Engineering – Cal State Los Angeles
- BS degree – Business Administration - University of La Verne

CERTIFICATIONS

- ICC Certified Building Official
- ICC Certified Building Inspector
- ICC Certified Building Plans Examiner
- California General Contractor
- ICC CALGreen Inspector/Plans Examiner
- ICC Building Code Specialist
- ICC Certified Sustainability Professional

Prior to joining Transtech, he has served in various capacities, including as Building Official/Code Administrator for the City of Pasadena, and managed/supervised over 35 technical, professional and administrative employees.

Building Official/Code Administrator

- The administrative head of the Code Enforcement Division of the Community Development Services Department and responsible for Development Processing, Building & Safety administration, Plan Check, Building Inspection, Zoning Code Enforcement

Supervising Engineering Plan Check Coordinator

- Supervised plans examiners and permit technicians
- Provided fire & life safety and structural plan checks
- Provided code interpretations, division policies and procedures.
- Provided plan check administration
- Provided Development Processing administration

Senior Structural Building Inspector

- Responsible for supervision of specialty and combination building inspectors including office and field.
- Provided complex commercial and residential building inspection.
- Responsible for inspector education updates and code revisions.

Mr. Dorman also has extensive experience in managing construction projects, owner representative services, code consulting, forensic investigative services, expert witness and construction mediation services. Project Management services to the City of Pasadena and the Pasadena Tournament of Roses Association for the \$22.5 million Rose Bowl Improvements Project; to the Pasadena Library Foundation and the City of Pasadena for the historical restoration of the Central Library. Acted as Owner' Representative, Transtech Engineers for the construction of a 14.5-acre, \$110 million cultural center educational campus with five buildings including cathedral, cultural center and museum, three level sports complex, monastery, community assembly building with a restaurant and large commercial kitchen above a 320-car subterranean parking garage.

AS PART OF THE ROLES AND RESPONSIBILITIES OF A BUILDING OFFICIAL, BELOW IS PARTIAL LIST OF DUTIES AS IT RELATES TO THE ROLE OF CHIEF BUILDING OFFICIAL POSITION:

- Represent City's as its building official while interfacing with the public and other agencies.
- Respond quickly in the event of a local, regional, or national emergency or disaster, as building official.
- Read, interpret and analyze plans for major structures.
- Visit construction sites and conduct building code inspections when needed as well as conduct job-site evaluations of construction projects for the purpose of monitoring/enforcing compliance with approved plans and code requirements.
- Oversee and participate in the management of a comprehensive building department processes.
- Oversee, direct, and coordinate the work of building staff.
- Participate in the development and administration of the division goals, objectives, and procedures.
- Prepare clear and concise administrative and financial reports as it related to the building department.
- Work with professional architects, engineers, builders, and the general public with a customer service approach.
- Formulate and apply uniform policies and standards for the building inspection programs; formulate, interpret and explain specific building codes, ordinances and administrative orders.
- Research regulations, procedures and/or technical materials relating to building codes and enforcement.
- Represent the City before other agencies and groups on building inspection and enforcement matters.
- Make effective presentations before large and small groups of people.
- Coordinate division services with other programs and services within the County and with outside organizations, and agencies.
- Analyze problems, identify alternative solutions, project consequences of proposed actions and implement recommendations in support of goals.
- Research, analyze, and evaluate new service delivery methods and techniques.
- Interpret and apply federal, state, and local policies, laws, and regulations.
- Communicate clearly and concisely, both orally and in writing

JEFFREY KAO, PE, CBO, CASp, ICC Certified Building Official, Plans Examiner and Inspector



Mr. Kao has 20 years of experience and has been working at Transtech as Deputy Building Official, Senior Plans Examiner, On-Site Over the Counter Plans Examiner and performed plan checks for a variety of residential and commercial projects under Transtech's Building and Safety Contracts at various Cities in Los Angeles County. His experience includes review and approval of architectural and structural plans submitted to municipalities for a wide variety of projects ranging from small residential additions to large, multistory commercial and industrial facilities. He also provides necessary code interpretations, and coordinates with agency staff and departments, and applicants on building and safety related issues. He also provides over the counter plan check as Deputy Building Official/Plans Examiner. He has extensive experience in Building Codes, plan check including building, grading and NPDES plan reviews, code interpretations and resolving code related construction and plan check problems on a broad range of residential and commercial projects.

His past experience includes working as a structural engineer for 4 years at a structural design firm. He was involved in various projects, including Mid-rise Steel Commercial Buildings, Steel Industrial High Bay Facilities, Wood Framed Public/Private Schools and Education Centers, Reinforced Concrete Masonry Studios and Auditoriums and Spreading Footing, Pile Foundation Design. His diversified experience gives him an excellent knowledge and understandings of "both sides of the counter."

EDUCATION

- UCLA, MS in Civil Engineering (Structural and Earthquake)
- California State Polytechnic University Pomona, BS in Civil Engineering

REGISTRATION

- California Registered Civil Engineer
- ICC Building Official
- ICC California Building Plans Examiner
- ICC CalGreen Inspector
- ICC CalGreen Plans Examiner
- ICC Mechanical Plans Examiner
- ICC Plumbing Plans Examiner
- ICC Building Inspector
- ICC CALGreen Inspector/Plans Examiner

HIGHLIGHTS

- Bilingual in Chinese
- Computer Aided Drafting: AutoCAD, Microstation
- Computer Aided Structural Analysis: SAP, STAAD

Knowledge of Building and Safety Procedures:

- Building and zoning codes and ordinances that are enforced and implemented at the city
- Quality customer service
- Procedures and techniques of permit processing and process for plan review and inspection
- Sound judgement in interpretation of codes and regulations
- Exemplary communications (oral and written), public relation

Project and Task Related Experience Working in Transtech's client cities:

- Provides technical information and assistance to engineers, architects, contractors, and general public
- Assists permit technicians in taking in plan check submittals
- Ensures that contractors provide proper documentation and valid license at time of permit issuance
- Research building plan check status
- Reviews plans to verify that all work proposed on plans is compliant with the code currently in effect
- Resolves issues diplomatically and tactfully
- Answers questions, concerns, or issues that residents, contractors, engineers, or business owners have regarding code
- Verifies with business license division that the occupancy group matches the type of use going into the tenant space
- Works closely with planning in resolving major projects by verifying key points on plans matched with planning's standards.
- Calculate fees for plan check and permits
- Reviews permit applications and issues permits

- Chinese Cantonese and Mandarin Speaker
- Extensive experience in Structural Plan Check
- Experience includes working as structural designer at a structural firm.
- Served as Deputy Building Official for a number Contract Cities

Project Experience working in Complex Projects (Partial List):

- 1439 W Main, Toyota Wondries – Building and grading plan check
- 700 N Stoneman , 70 condo units – grading plan check
- 500 S Marengo, Home Depot Expansion – building plan check
- 1139 W Main, BMW Expansion – grading plan check
- 1 W Hellman, new medical office building – grading plan check
- 113-117 N Palm, 7 condo units – grading plan check

MICHAEL ROBERTS, CBO, MCP, ICC Certified Building Official, Plans Examiner and Inspector



Mr. Roberts has over 30 years of experience in municipalities, including governmental development administration. He has reached the highest possible level of code administration with the Master Code Professional designation certification from the International Code Council and has proven superior leadership abilities. Mr. Roberts holds over 20 International Code Council issued professional certifications, 5 International Conference of Building Officials certifications, and 17 Oregon Building Codes Division certifications.

He has served as Building Official, Community Development Director, Senior Plans Examiner, Plans/Residential Examiner, and Inspector for various municipalities and served as Principal Consultant. Serving as a Building Official for many years, Mr. Roberts provided the necessary code interpretations, and coordinated with agency staff and departments, and applicants on building and safety related issues. He has vast knowledge of municipal government operations, including preparation and presentation of staff reports and resolutions to city councils, committees and related interaction with members of the public, other city departments, and other governmental agencies.

Mr. Roberts currently performs remote Plan Review for various Transtech contract cities including City of West Covina, South Pasadena, Alhambra, Seal Beach, South El Monte, Monterey Park, Temple City, Commerce, and Hawaiian Gardens. He has extensive experience in construction codes, building and safety plan review and inspection, code interpretations, and resolving code related construction and plan review problems on a broad range of projects. Mr. Roberts has excelled in working effectively, both in a team and independently, to successfully complete projects and achieve measurable results. He is a strong communicator, problem solver, cooperative team player.

EDUCATION

- Associate of Applied Science, Building Inspection Technology – Chemeketa Community College, Salem Oregon
- Fire Code Administration, National Fire Academy – Emmitsburg, Maryland
- Supervisory Leadership – Oregon State University, Bend, Oregon

CERTIFICATIONS

ICC Certifications:

- Master Code Professional
- Building Code Official
- Building Official
- Plumbing Inspector
- Combination Inspector
- Commercial Building Inspector
- Accessibility Plans Examiner / Inspector
- Commercial Energy Conservation Plans Examiner
- Commercial Energy Conservation Inspector
- Electrical Inspector
- Commercial Electrical Inspector
- Residential Electrical Inspector
- Residential Energy Conservation Inspector
- Residential Building Inspector
- Residential Mechanical

HIGHLIGHTS

- 2006 “Public Official of the Year” Central Oregon Builders Association
- 2008 Oregon “Building Official of the Year” Oregon Building Officials
- 2009 President of Oregon Building Officials
- 2008 Vice President Oregon Building Officials
- 1998 President of Oregon Mechanical Officials
- 1995 and 1999 President Central Oregon Building Officials
- 2005 to 2014 Scholarship Chair Central Oregon Building Officials
- 2008 to 2014 Education Chair Central Oregon Building Officials
- Served on House Bill 2478 for Manufactured Dwellings

Professional Experience:

Building Official – City of Oregon City

- Created a community development monthly stakeholders meeting that is open to the public. Discussions include upcoming changes to the city development programs, which

- Inspector
- Residential Plans Examiner
- Mechanical Inspector
- Commercial Mechanical Inspector
- Fire Code Inspector Fire Inspector II

International Conference of Building Officials:

- Structural Inspector
- Plumbing Inspector
- Mechanical Inspector
- Building Plans Examiner
- Fire Code Official

Oregon Building Codes Division:

- Building Official
- A Level Structural Inspector
- A Level Mechanical Inspector
- A Level Plumbing Inspector
- A Level Plans Examiner
- Fire Life Safety Plans Examiner
- Residential Structural Inspector
- Residential Plumbing Inspector
- Residential Mechanical Inspector
- Residential Electrical Inspector
- Residential Plans Examiner
- Park and Camp Inspector
- Manufactured Dwelling Installation Inspector
- Manufactured Dwelling Construction Inspector
- Post-Earthquake Inspector
- Third Party Inspector
- Oregon Inspector Certification

also allows attendees to openly discuss streamlining the community development process.

- Updated the Building Division policies and procedures to be in compliance with the Oregon Administrative Rules regarding building inspection programs.
- Completed a comprehensive review of the building program fees and successfully presented the proposed fee adjustment to the State Building Codes Division and the City Commission which was updated for the first time since 2001.
- Reviewed the intergovernmental agreements between the City of Oregon City and Clackamas County for inspection services and reduced the city’s monthly spending by bringing a full complement of inspection services in house

Principal Consultant – Northwest Code Consulting, LLC

- Developed the current curriculum for the Federal Bureau of Labor North West Tribal Code Officials Apprenticeship Program.
- Partnered with South Seattle Community College and the Washington Association of Building Officials to start an accredited building inspection program that would allow college degrees upon completion.
- Provided planning and building code consulting for the Indian Head Casino and a new fire station at the Sid Walter Flats region on the Warm Springs Reservation.
- Created a full service Building and Planning Program that could be administered by tribal members of the Confederated Tribes of the Warm Springs Reservation of Oregon and the Siletz Confederated Tribes.
- Provided building and planning consulting services to development projects in ten different states.
- Provided expert witness testimony and technical report writing in building and planning litigation.

Building Official / Community Development Director – Jefferson County

- Building official for the construction of the \$190,000,000 Deer Ridge Correctional Facility.
- Interim Community Development Director overseeing planning, building, code enforcement and on-site environmental health.
- Distance Learning Instructor for Portland Community College providing curriculum and experience for students aspiring to become Code Officials.

Senior Plans Examiner – Deschutes County

- Senior Commercial Plans Examiner overseeing all commercial plan reviews for the county, which included working with eight different fire districts and six different cities with partial building inspection programs.
- Lead code official for the North County Operations.
- Distance Learning Instructor for Chemeketa and Portland Community College providing curriculum and experience for students aspiring to become Code Officials.

Building Official – City of Bend

- Promoted to building official, having started as a residential plans examiner.
- Instructor for Chemeketa Community College for summer interns program allowing students enrolled in the program to earn college credits.
- After reviewing over 12,000 commercial and residential building projects, played a part in growing the population of the City of Bend from 33,000 to over 100,000 today.
- Building staff member assigned at the beginning of the Old Mill Development.
- Member of development review team for over 4,000,000 square feet of industrial space.
- Served two consecutive terms as the City of Bend Employees Association President.

Inspector/Plans Examiner – City of Coos Bay

- Performed residential and commercial plan reviews and inspections, reporting directly to the building official who was also the Community Development Director.
- Lead inspector for the largest project at the time for the Oregon Coast: construction of a 120,000 square foot Wal-Mart Super Store and Distribution Center.
- Deputy Fire Marshal and Inspector, completing annual fire inspections of existing businesses, new business license inspections, inspections of firework stands, and providing education on fire prevention.

Residential Plans Examiner – City of Beaverton

- Temporary residential plan examiner hired during the last term of college.

International Brotherhood of Electrical Workers

- Worked as an apprentice lineman out of Local 1245 Sacramento.

CALVIN CHANG, PE, ICC Certified Plans Examiner



Mr. Chang has 30 years of experience and has been working at Transtech as Deputy Building Official, Senior Plans Examiner, On-Site Over the Counter Plans Examiner. He has performed plan checks for a variety of residential and commercial projects in Cities of Alhambra, Temple City, Huntington Park, San Manuel Indian Reservation and San Bernardino. Prior to joining Transtech, he was a Sr. Plans Examiner at the City of Burbank.

Mr. Chang has extensive experience in Building Codes, code interpretations and resolving code related construction and plan check problems on a broad range of residential and commercial projects.

Some of the large and complex projects he plan checked include:

- Burbank Airport Transportation Center, 4-Story, type I construction
- 4-story with 3-level underground parking mixed-use project, retails with 142-unit apartments above, type I / type III-one hour construction
- Burbank Verdugo Park Recreation Center, 1-story assembly use, type V-B construction
- 40-acre Burbank Empire Center with anchor stores, i.e. Lowes, Best Buy, Costco, Extended Stay Inn, office buildings, retails stores
- Warner Bros and Disney studio campus development with office buildings and mass tenant improvement
- 75-unit Marriott Courtyard hotel, 4-story, type V-one hour construction
- 1-story Industrial Warehouse, 40,000 sf, type V-B construction
- Burbank hillside 82-unit single family homes development
- 36 SFD and 28 Townhomes
- 70 unit condo
- Mixed use project – Commercial on bottom, 120 apartment units above

EDUCATION

- MS, Civil Engineering
Tennessee Technological University, Cookeville, TN
- BS, Civil Engineering
Chung-Yuan University, Chung-Li, Taiwan

REGISTRATION

- State of California
Registered Civil Engineer
- ICC Plans Examiner

HIGHLIGHTS

- Chinese Cantonese and Mandarin Speaker
- Extensive experience in Structural Plan Check

HIGHLIGHTS

Proficient in Microsoft Excel, PowerPoint, Word, & Outlook

Project and Task Related Experience Working in Transtech's client cities:

- Answers questions applicants and residents have on code requirements and regulations
- Enforcing and implementing municipal code and city adopted building code
- Review building plans and related documents for compliance with building codes, policies, and jurisdiction requirements
- Provides technical help to building inspectors and permit technicians in difficult field situations as well as applicant questions
- Answering emails, phone calls, or counter questions regarding corrections given on plan checks

ROBERT HERNANDEZ, ICC Certified Plans Examiner and Inspector

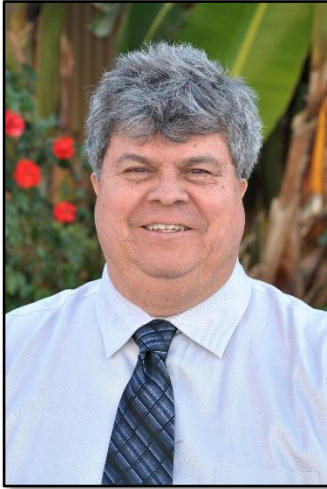

Mr. Hernandez has over 30 years of experience and has served as Inspector and Plan Checker. His prior experience includes:

- City of San Clemente, Community Development Specialist: Plan check, provide backup counter coverage for over-the-counter reviews.
- City of Hemet, Plans Examiner: Plan check various projects both residential and commercial. Assign work for contract plan checker. Provide ongoing training for staff. Provide counter coverage back-up as needed. Write office policies and procedures. Represent department in Design Review Committee.
- D & J Engineering, Diamond Bar, Building Inspector: Provide daily field inspections to contract cities. Plan check of various projects. Provide assistance to the public at counter.
- Radco, Long Beach, Consultant Plan Checker: Plan check for manufactured housing and recreational vehicles. Inspect manufactured housing as needed.
- Handyman Connection, Dispatcher/Scheduler: Input service requests into computer and issue jobs to contractors Estimate job duration and labor cost.
- County of San Bernardino, Building Inspector 3/ Plan Checker: Plan check residential and commercial projects. Supervise building Inspector 1, 2 positions and Land Use Technicians. Assist in running daily operation of regional office in Ontario, California.
- City of Fullerton: Building Inspector 2: Commercial and residential inspections during all phases of construction. Plan check of plumbing, mechanical minor residential projects. Assist in training new inspectors.
- City of Beverly Hills: Building Inspector 2: Commercial and residential inspections during all phases of construction. Plan check of plumbing, mechanical minor residential projects. Assist in training new inspectors.
- City of Long Beach, Combination Building Inspector Aide: Building inspector trainee, code enforcement.
- W.A. Deel & Sons, Los Angeles, Journeyman Plumber: Plumber for new construction and remodeling hospitals. Layout work for crews and assist in training new apprentices.
- Local Union 761, Burbank, Plumber: Attend apprenticeship classes. Plumber for hotel, aircraft facilities, manufacturing plants and tract housing.

EDUCATION

- Cal State Univ. Long Beach, California – Teaching credential
- Riverside Community College – Fundamentals of Management
- Coastline Community College – electrical and mechanical code classes.
- Fullerton Community College – building construction code classes.
- Cal State Univ. Los Angeles – attended three years pursuing engineering degree

CERTIFICATIONS

- ICC Building Inspector
- ICC Building Plans Examiner
- ICC Commercial Building Inspector
- ICC Commercial Plumbing Inspector
- ICC Plumbing Inspector
- ICC Residential Building Inspector
- ICC Residential Plumbing Inspector

Knowledge of Building and Safety Procedures:

- Various municipal, building, electrical, mechanical, and plumbing codes
- Ensures plans follow codes, regulations and ordinances
- Attentive to applicant's inquiries, concerns, or questions
- Communicate clearly to applicants about code compliance
- Plan check submittal process and permit issuance

Project and Task Related Experience Working in Transtech's client cities:

- Review building plans and related documents for compliance with building codes, policies, and jurisdiction requirements
- Provides clear and detailed code requirements and regulations for developers, contractors, public and building department staff

- CalOES SAP Evaluator

HIGHLIGHTS

- Proficient in Microsoft Excel, PowerPoint, Word, & Outlook

- Provides technical assistance to building inspectors and permit technicians in difficult field situations as well as applicant questions
- Calculates fees for both plan check and permits
- Assists permit technician at the public counter, accepting building plan review applications, accepting plan submittals, and issuing building permits
- Resolves questions that applicants, homeowners, developers, or contractors may have on certain projects

Administrative Building and Safety Duties

- Maintains and keeps all documents, plans, and paperwork organized
- Conducts administrative write ups for plan checks
- Answers questions regarding plan check corrections at the counter, on the phone, or through email

VINCENT ALTUNA, ICC Certified Inspector



Mr. Altuna is a Building Inspector with 15 years of experience. He is available to provide a combination of building inspector services to many of our Southern California clients. Mr. Altuna has served as a Building Inspector at various Transtech Contract Cities including largely at the City of Commerce. As a building inspector he provides building and safety related services for the Building Division/Departments in the areas of residential, commercial, and industrial related projects. Some of Mr. Altunas' responsibilities as a building inspector include building, electrical, mechanical, and plumbing inspections; ensuring that all proper documents are obtained prior to finalization of permits; and answering questions that contractors, developers, engineers, or homeowners might have regarding code requirements. He has broad knowledge of municipal governmental operations and building related codes and ordinances.

EDUCATION

- Electrical Code, Blueprint Reading, Intro to International Building Code, Coastline Community College, Fountain Valley, CA
- 13 Years' Experience

CERTIFICATIONS

- ICC Certified Building Inspector

HIGHLIGHTS

- Proficient in Microsoft Excel, PowerPoint, Word, & Outlook
- Cal OSHA 10 hour Construction Certified

Prior to working for Transtech Engineers, Mr. Altuna worked as a Senior Building Inspector for various consulting groups across Southern California. During this time, he worked in the Building & Safety Departments at the Cities of Huntington Beach, Industry and Cudahy. Mr Altunas' experience also includes Public Works Inspections and Building & Public Work Permit Issuance.

Relevant Prior Experience:

- Senior Building Inspector at various Municipal Governmental Agencies
- Managed Building & Safety Departments
- Organized filed, permits, and plans
- Residential and Commercial Inspections
- Public Works Inspections (Traffic, Street, Sidewalk and Approaches)
- Counter (Building & Public Work Permit Issuance, Process Plans for submittal)
- Basic Over-the Counter Plan Checking
- Quarterly Reports (Seismic)
- Managed and inspected street, sidewalk, curb-cuts, and gutter improvement projects
- Inspections in plumbing, heating and electrical
- General knowledge of reviewing home and building plans
- Knowledge of building related codes and ordinances
- Maintaining inspection reports, records, and making recommendations as needed

Project and Task Related Experience Working in Transtech's client cities:

- Document retention and record keeping and policies
- Knowledge of construction standard safety when out on the job site
- Municipal code and city adopted building, electrical, mechanical, and plumbing code
- Implement and enforce building and municipal codes

- Maintains organized and neat record keeping and procedures
- Performs building field inspections including electrical, mechanical, and plumbing work
- Provides information to contractors, developers, engineers regarding code requirements
- Reviews, understands, interprets, and analyzes construction plans, specifications, and maps in conformance with city standards and policies
- Ensures that all proper documentation and departmental final inspections are obtained prior to finalizing permit
- Answers questions or concerns public may have at the counter, on the phone, or through email
- Answers all code related questions pertaining to inspections
- Supervises all building inspectors and may provide training to building inspectors
- Establish, maintain, and cultivate positive and congenial working relationships with those contacted in the course of the work

Project Experience working in Complex Projects (Partial List):

- 5200 Triggs Street - Harbor Freight (20,000 sq. ft. tilt-up)
- 2222 Yates Avenue - Palisades Washington Center (44,000 sq. ft. tilt-up)
- 5401 Telegraph Road - Alta Med Parking Structure (5 levels w/elevator)
- 7140 Bandini Blvd. - JFC Expansion Building (171,000 sq. ft. tilt-up w/50,000 sq. ft. freezer)
- 7400 Slauson Avenue - Replace Fire Damaged Building (20,000 sq. ft. CMU Building)
- 5941 Corvette Street - Hollywood Bed & Frame (15,000 sq. ft. CMU Building)
- 1270 Goodrich Blvd. - Telacu (175,000 sq. ft. tilt-up)
- 6555 Gage Avenue - Parklawn Memorial Mausoleum (46,586 sq. ft. Above Ground Mausoleum).

JASON ROBBINS, Deputy Building Official, ICC Certified Building Inspector, CALGreen Inspector/Plans Examiner, Permit Technician



Mr. Robbins has over 8 years of experience working in governmental environments. He is assigned to various Transtech Contract Cities. He has served as Permit Technician and as Building Inspector under Transtech's contract cities, including at the City of Alhambra, City of South Pasadena, City of Temple City, City of West Covina, City of Montebello, and City of Seal Beach. In addition to this, Mr. Robbins experience includes over the counter Plan Check work at the City of Downey and City of Alhambra. Mr. Robbins also has experience working alongside Los Angeles County Staff at City of Commerce as a Permit Technician. Some of Mr. Robbins' roles as a building inspector includes conducting building, electrical, mechanical, and plumbing inspections; ensuring that all proper documents are obtained prior to finalization of permits; and answering questions that contractors, developers, engineers, or homeowners may have regarding code requirements.

Along with working as an inspector, Mr. Robbins has prior experience as a Permit Technician, taking in plan submittals, processing permits, and calculating plan check and permit fees. In addition to these roles, his tasks also include creating reports for departmental use and for outside agency use such as for SMIP or BSASRF; entering permits into the city's database; and providing quality customer service to the public and to city staff.

EDUCATION

- A.A. Associate of Arts Degree -Citrus Community College
- A.S. Associate of Science Degree – Citrus Community College
- California State University of Los Angeles – Upperclassman Computer Science (In Progress)
- Deans Honor Roll

CERTIFICATIONS

- ICC Certified Residential Plans Examiner
- ICC CAL Green Inspector/Plans Examiner
- ICC Certified Building Inspector
- ICC Certified Commercial Building Inspector
- ICC Certified Residential Combination Inspector

Project and Task Related Experience Working in Transtech's client cities:

- Record keeping and policies
- Ensure that all safety standards of building construction related to work on enforced
- Plan check submittal process and permitting process
- Clear and concise record keeping and policies
- Implementing and enforcing building and municipal codes
- Performs building field inspections including electrical, mechanical, and plumbing work
- Provide written corrections or approvals on inspections in the field
- Input all inspection results into Excel
- Take in inspection requests for next day inspections, map out inspection route, input all inspections for the following day, and prepare permits for the next day inspection
- Assist permit technicians with over-the-counter permits
- Investigate unpermitted work and issue stop-work orders if necessary
- Provides information to contractors, developers, engineers regarding code requirements
- Review, understand, interpret, and analyze construction plans, specifications, and maps in conformance with city standards and policies
- Receive all proper departmental final inspections and documentations prior to finalizing construction permits
- Ensure that all proper documentation and departmental final inspections are obtained prior to finalizing permit
- Sending approval of electrical and gas meter releases to utility providers

- ICC Certified Residential Building Inspector
- CalOES SAP Evaluator
- ICC Certified Residential Electrical Inspector
- ICC Certified Residential Mechanical Inspector
- ICC Certified Residential Plumbing Inspector
- ICC Certified Permit Technician

Project Experience working in Complex Projects (Partial List):

- 2400 S Fremont Ave – 36 SFD and 28 Townhomes – Building Inspections
- 113-117 N Palm Ave – 7 Unit Condos – Building Inspections
- 2300-2330 W Commonwealth Ave – 3 New Commercial Building – Building Inspections
- 300 W Main St/11 S 3rd St – Mixed Use – Issuing temporary occupancy with guidance and instruction from building official

HIGHLIGHTS

- Proficient in Microsoft Excel, PowerPoint, Word, Outlook, QuickBase, Access
- Municipal permitting systems: Accela Permit Plus (City of Commerce), File Maker Pro (City of Seal Beach)
- Over the Counter Plan Check (City of Downey and City of Alhambra)

GREGORY AHERN, ICC Certified Inspector, ICC Certified Fire Inspector



Mr. Ahern has over twenty years' experience inspecting commercial development in the City of Glendale. Mr. Ahern has extensive experience with Federal, State, and local Fire and Building Code Regulations. He has in depth experience inspecting high rise mixed use development projects, as well as industrial projects. Mr. Ahern has acted as the lead inspector working with public agencies, the business community, and the public. Mr. Ahern is currently assigned to various Transtech Contract Cities including City of Alhambra and City of South Pasadena where he serves as the Building Inspector. Some of Mr. Ahern's roles as a building inspector includes conducting building, electrical, mechanical, and plumbing inspections; ensuring that all proper documents are obtained prior to finalization of permits; and answering questions that contractors, developers, engineers, or homeowners may have regarding code requirements. In addition to this, Mr. Ahern's experience includes observation of construction of residential and commercial buildings, precise grading, park facilities, community centers and single-family homes with multi-phased plans. His prior experience includes mechanical, electrical, plumbing, building, minor structural, and precise grading inspection with leading developers.

EDUCATION

- Associates of Science Degree – Public Works Construction - Citrus Community College
- FT 101: Fire Protection Organization, FT 102: Fire Prevention Technology, FT 103: Fire Protection Equipment System, FT 104: Building Construction/Fire Protection, FT 105: Fire Behavior & Combustion – Hancock Community College

CERTIFICATIONS

- ICC Residential Combination Inspector
- ICC Residential Building Inspector
- ICC Residential Electrical Inspector
- ICC Residential Mechanical Inspector
- ICC Residential Plumbing Inspector
- ICC Fire Inspector I
- ICC California UST Inspector
- Hazardous Waste Operator and

Project and Task Related Experience Working in Transtech's client cities:

- Record keeping and policies
- Ensure that all safety standards of building construction related to work on enforced
- Plan check submittal process and permitting process
- Clear and concise record keeping and policies
- Implementing and enforcing building and municipal codes
- Performs building field inspections including electrical, mechanical, and plumbing work
- Provide written corrections or approvals on inspections in the field
- Input all inspection results into Excel
- Take in inspection requests for next day inspections, map out inspection route, input all inspections for the following day, and prepare permits for the next day inspection
- Assist permit technicians with over-the-counter permits
- Investigate unpermitted work and issue stop-work orders if necessary
- Provides information to contractors, developers, engineers regarding code requirements
- Review, understand, interpret, and analyze construction plans, specifications, and maps in conformance with city standards and policies
- Receive all proper departmental final inspections and documentations prior to finalizing construction permits
- Ensure that all proper documentation and departmental final inspections are obtained prior to finalizing permit
- Sending approval of electrical and gas meter releases to utility providers

Previous Experience:

Building Inspector (Through HR Green Pacific)

- Emergency Operations Certification (HAZWOPER)
- Aboveground Petroleum Storage Tank Inspector Certification EPA (APSA)

- Observation of the construction of residential and commercial buildings, precise grading, retaining walls, park facilities, community centers, apartments, and single-family homes with the multi-phased Ranch Plan for compliance to approved plans and codes. This has included mechanical, electrical, plumbing, building, minor structural, and precise grading inspection associated with leading developers, such as Rancho Mission Viejo, Standard Pacific, Shea Homes, Tri Pointe, Ryland, William Lyon, Meritage, Western Pacific, Pulte, and Sea Country.

OTHER CERTIFICATES

- Fire Prevention Officer
- Fire Safety Officer Motion Picture/Television Certification
- Proximate Audience Pyrotechnics
- Outdoor Public Displays Pyrotechnics
- Fire Prevention 1A, 1B, 1C, 2A, 2B, 2C, 3A, 3B
- Fire Management 1
- Statutes and Regulations
- Safety Assessment Program: Evaluator and Coordinator Training

Senior Fire / Environmental Safety Specialist

Glendale Fire Department

- Mentor, coach, and oversee technical work of junior inspectors
- Inspect major / complex new-construction projects for both Building and Fire Code compliance as well as Environmental Regulatory compliance
- Inspect Film and Television production on location and in studios
- Provide Technical assistance to Fire Department personnel during and after emergency incidents
- Develop solutions to design problems in development and construction projects
- Plan check and inspect Underground and Aboveground Storage Tanks, Industrial Waste and Pretreatment Systems, Hazardous Materials / Hazardous Waste –plan review, field inspection,
- Fire alarm and detection systems, fire sprinkler systems, standpipes, fire pumps, smoke control systems – planning, field inspection, commissioning
- Inspect commercial and residential occupancies for fire and life safety
- Lead technical training and familiarization tours for firefighters and fire academy students
- CUPA Inspector (Certified Unified Program Agency)

HIGHLIGHTS

- Proficient in Microsoft Excel, PowerPoint, Word, Outlook, QuickBase, Access
- California State Fire Marshal

Industrial Waste Inspector

Glendale Public Works

- Plan check and field inspections of both new and existing occupancies for Federal, State and local regulatory compliance for Underground Storage Tanks and Industrial Waste
- Pretreatment
- Developed and implemented sampling protocols to comply with EPA Standards, citywide permitting system
- Wastewater sampling at commercial and industrial sites and throughout City infrastructure
- Underground Storage Tank removals inspection and post-removal remediation
- Technical environmental training to Fire personnel when program transferred to Fire Department

JEREMY REED, ICC Certified Building Inspector, Permit Technician



Mr. Reed has over 7 years of experience working in governmental environments. He is assigned to various Transtech Contract Cities. Mr. Reed has served as a Permit Technician and a Building Inspector under contract cities such as City of South Pasadena, Alhambra, and Hawaiian Gardens. Some of Mr. Reeds roles as a building inspector include conducting building, electrical, mechanical, and plumbing inspections; ensuring that all proper documents are obtained prior to finalization of permits; and answering questions that contractors, developers, engineers, or homeowners may have regarding code requirements.

Along with working as an inspector, Mr. Reed is largely involved with working alongside our Permit Technicians. Using his prior experience as a Permit Technician, Mr. Reed also works in taking in plan submittals, processing permits, and calculating plan check and permit fees. In addition to this, his duties include answering building code questions along with general building questions (which include plan submittal, permits, etc.) over the phone or at the counter; working closely with permit technicians to maintain communication on various projects that should be brought to attention; and filing away permits at the end of the day after finishing up inspections. Prior to joining Transtech, Mr. Reed worked in the customer service sector where he was able to develop exceptional teamwork and communication skills that translate to his day to day engagement with the public.

EDUCATION

- Citrus College

CERTIFICATIONS

- ICC Residential Building Inspector
- ICC Permit Technician
- CalOES SAP Evaluator

HIGHLIGHTS

- Proficient in Microsoft Excel, PowerPoint, Word, & Outlook

Knowledge of Building and Safety Procedures:

- Plan check submittal and permitting process, document retention and record keeping and policies
- Municipal code and city adopted building, electrical, mechanical, and plumbing code
- Safety equipment and practices related to the work, including safe driving rules and practices
- Provide highly qualified customer service and communication with staff members and the public
-

Project and Task Related Experience Working in Transtech's client cities:

- Performs building field inspections including electrical, mechanical, and plumbing work
- Provide written corrections or approvals on inspections in the field
- Input all inspection results into Excel. Calculate and process permit and mitigation fees and provides fee estimates as requested
- Take in inspection requests for next day inspections, map out inspection route, input all inspections for the following day, and prepare permits for the next day inspection
- Assist permit technicians with over-the-counter permits
- Investigate unpermitted work and issue stop-work orders if necessary
- Provides information to contractors, developers, engineers regarding code requirements
- Review, understand, interpret, and analyze construction plans, specifications, and maps in conformance with city standards and

policies. Ensure that all proper documentation and departmental final inspections are obtained prior to finalizing permit

- Sending approval of electrical and gas meter releases to utility providers

-

Project Experience working in Complex Projects (Partial List):

- 22417 Elaine Ave, City of Hawaiian Gardens – Residential Single Family Homes
- 22408 Elaine Ave, City of Hawaiian Gardens – Residential Single Family Homes
- 12508 Carson, City of Hawaiian Gardens – Commercial 5 Story Storage Facility

JONATHAN TARANGO, Deputy Building Official, ICC Certified Building Inspector, CALGreen Inspector/Plans Examiner, Permit Technician

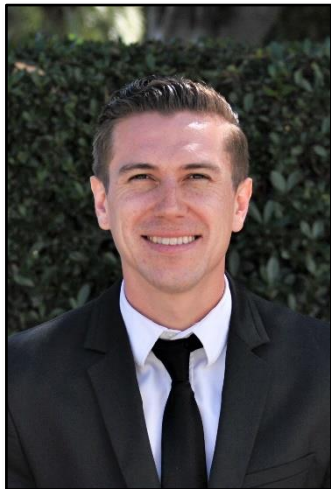

Mr. Tarango has over 8 years of City government experience working in many diverse communities. His experience includes working as a Building Inspector and Permit Technician at various Transtech contract cities. With a strong background in construction, excellent customer service skills, and broad range of computer abilities he has been a great asset to the Building Division. His duties include answering building code questions along with general building questions (which include plan submittal, permits, etc.) over the phone or at the counter; working closely with permit technicians to maintain communication on various projects that should be brought to attention; and filing away permits at the end of the day after finishing up inspections. In addition to his duties, Mr. Tarango also goes above and beyond by helping and assisting the permit technicians with issuing permits, taking in plan check submittals, as well as entering permits into a database.

EDUCATION

- Construction Management, Fullerton College
- General Education, Mount San Antonio College

CERTIFICATIONS

- ICC Residential Building Inspector
- ICC Residential Plumbing Inspector
- ICC Residential Electrical Inspector
- CalOES SAP Evaluator

HIGHLIGHTS

- Proficient in Microsoft Excel, PowerPoint, Word, & Outlook
- Cal OSHA 10-hour Construction Certified

Prior to working for Transtech Engineers Mr. Tarango worked in the City of Diamond Bar as a Building Inspector Technician. Some of his responsibilities included site inspections of residential and commercial projects, site grading, answering questions and providing information to the public, review of permit applications for completeness and accuracy, determining appropriate fees, routes plans, and issues permits.

Knowledge of Building and Safety Procedures:

- Knowledge of methods, materials, and safety standards of building construction
- Safety equipment and practices related to the work, including safe driving rules and practices
- Record keeping and policies
- Implement and enforce building and municipal codes
- Plan check submittal process and permitting process
- Provide highly qualified customer service and communication with staff members and the public

Project and Task Related Experience Working in Transtech's client cities:

- Performs building field inspections including electrical, mechanical, and plumbing work
- Provide corrections or approvals on inspections out in the field
- Input results of field inspections into excel
- File away permits after inspections are completed
- Take inspection requests, route out inspections for the following day, prepare all permits for the next day's inspection
- Release electrical and gas meters to utility providers
- Request for final inspections from appropriate departments prior to final of building permits
- Assist permit technicians with over-the-counter permits
- Take in plan check submittals
- Respond to questions, concerns, issues public may have at the counter, on the phone, or through email
- Investigate unpermitted work and issue stop-work orders if necessary

- Works closely with Code Enforcement to conduct follow-up inspections to ensure compliance and complete case files
- Maintain a clean and orderly office and desk area
-

Project Experience working in Complex Projects (Partial List):

- 2400 S Fremont Ave – 36 SFD and 28 Townhomes – Building Inspections
- 113-117 N Palm Ave – 7 Unit Condos – Building Inspections
- 2300-2330 W Commonwealth Ave – 3 New Commercial Building – Building Inspections

TIMOTHY O’CONNER, ICC Certified Building Inspector



Mr. O’Conner has over 9 years’ experience in construction including commercial, residential, and tilt-up construction. Mr. O’Conner is a Certified Building Inspector and a Certified Combination Dwelling Inspector with experience in the Los Angeles City code requirements, including the City’s zoning applicable to the construction, alteration and repair of single-family residences, residential buildings up to 10 units, accessory buildings and swimming pools. He has knowledge in instructing inspectors in the proper procedures and techniques of inspection and the application of interpretation of building, mechanical and zoning code provisions and department policies. He has also obtained approvals by inspectors in numerous facets of construction.

Currently, Mr. O’Conner is assigned to various Transtech Contract Cities including City of West Covina and City of Azusa where he is serving as the Building Inspector. Some of Mr. O’Conner’s duties include conducting building inspections and ensuring that all documents are obtained prior to finalization of permits. He also ensures and answers any questions that contractors, developers, engineers or homeowners may have regarding code requirements. In the past, Mr. O’Conner personally administered training to inspectors and assistant inspectors, planned, organized and directed the operation of a code enforcement program. He has also administered regulations, adjudications, and interpretations relating to the mechanical inspection activities and enforcement problems.

EDUCATION

- Los Angeles Trade Tech – Supervision Course

CERTIFICATIONS

- ICC Certified Building Inspector
- ICC Certified Combination Dwelling Inspector
- Management Resource Inc., Leadership Library
- Management Leadership Library, Looking into Leadership
- CalOES SAP Evaluator

HIGHLIGHTS AND QUALIFICATIONS

- Represented the Department in front of the Building and Safety Commission and acted as a Hearing Examiner.
- Represented Resource Management as Custodian of Records
- Prepared staff reports for management and Board of Building and Safety Commission, and “Statement of Facts” reports for City Attorneys.
- Handled full authority in supervising, assigning, and reviewing the work of Building Mechanical Inspectors.
- Conducted field inspections when difficult enforcement or public relation problems arise; investigated cases of noncompliance following the issuance of Order to Comply.
- Assisted in training other inspectional employees as required.
- Principles of supervision – budgetary and administrative practices and procedures.

Project and Task Related Experience Working in Transtech’s client cities:

- Proficient in Microsoft Excel, PowerPoint, Word, Outlook, QuickBase, Access
- Over the Counter Plan Check (City of Alhambra)
- Clear and concise record keeping and policies

- Ensure that all safety standards of building construction related to work on enforced
- Plan check submittal process and permitting process
- Standards of good building and mechanical construction, materials, procedures, and practices, as required to inspect residential structures.
- Implementing and enforcing building and municipal codes
- Take in inspection requests for next day inspections, map out inspection route, input all inspections for the following day, and prepare permits for the next day inspection
- Investigate unpermitted work and issue stop-work orders if necessary
- Provides information to contractors, developers, engineers regarding code requirements
- Ensure that all proper documentation and departmental final inspections are obtained prior to finalizing permit

NICHOLAS TARANGO, ICC Certified Building Inspector, Permit Technician



Mr. Tarango has been with the Transtech Team for over 5 years and currently works as a Building Inspector for contract cities such as City of Maywood and City of Hawaiian Gardens. Some of his responsibilities include performing routine and standardized building inspections to ensure compliance with applicable codes, ordinances, and regulations. Mr. Tarango's experience also includes working as a Permit Technician in City of South Pasadena and City of Alhambra. As a permit technician he performs preliminary review of permit applications and plan submittals for completeness and accuracy and determines appropriate fees. In addition, he also routes plans, issues permits, and manages logs and records, and provides information to the public relating to the status of projects and permits.

Mr. Tarango works largely with the City of South Pasadena as our head Permit Technician. Some of his duties include resolving permit or project related issues, coordinating building plan review and inspection issues and works on receiving and reviewing applications. Mr. Tarango staffs and manages the building permit counter for the City of South Pasadena while providing information and direction to the public on building issues relating to processes and requirements. Mr. Tarango spends a large amount of his time interacting with customers and responding to their needs. Prior to working for Transtech Engineers, Mr. Tarango worked largely in the Customer Service sector where he was able to advance through several positions and levels of responsibility at a restaurant. There, he learned how to work collaboratively and efficiently with customers and different levels of management.

EDUCATION

- Graduate of Brea Olinda High School
- Fullerton College

ICC CERTIFICATIONS

- ICC Residential Building Inspector
- ICC Permit Technician
- Home Inspection, Allied Schools

HIGHLIGHTS

- Proficient in Microsoft Excel, PowerPoint, Word, & Outlook

Skills:

- Communicating clearly and concisely
- Customer Service principles and practices including conflict resolution
- Effectively communicate clearly and concisely, both orally and in writing
- Successful working in a team environment

Knowledge and Project Related Experience of Building and Safety Procedures:

- Procedures and techniques of permit processing and process for plan review and inspection.
- Plan check submittal process and permitting process
- Building and zoning codes and ordinances enforced by the city.
- Processes for compiling and analyzing data for special projects.
- Interpret and explain policies and regulations accurately and tactfully to the public.
- Understanding, enforcing, and implementing city municipal code as well as the city's adopted building code
- Calculate and process permit, and mitigation fees and provides fee estimates as requested.

- Answering phone calls and emails that applicants and residences have questions on
- Answering questions applicants and residents have on the building department plan check, permitting, and inspection process
- Guiding potential applicants on submittal process; what requires plan check; what doesn't require
- Gather all departmental approvals prior to letting applicant know permits are ready to be issued; contacting applicant of corrections of plans
- Taking in plans for plan check submittal
- Completing public requests
- Maintaining a neat and orderly counter and keeping all permits and documents in the correct order
- Take inspection requests for the next day
- Pull out all permits required for the next day inspection

Project Experience working in Complex Projects (Partial List):

- 1401 Huntington (South Pasadena)– New Grocery Store
Processed fees, issued permits, scheduled for inspection
- 901 Fair Oaks (South Pasadena) – 6 Unit Commercial Multi use
tenant Improvement
Processed fees, issued permits, scheduled for inspection

ROCIO GONZALEZ, ICC Certified Permit Technician



Mrs. Gonzales has served as a Permit Technician for six years at various Transtech Contract Cities which include City of Alhambra, City of South Pasadena, City of Temple City, City of West Covina, and City of Huntington Park.

As a permit technician she receives and processes various permit applications, plans, and specifications, determining appropriate fees, routes plans, issues permit, provide other information of a general and technical nature.

Her prior experience includes 10 years as customer service representative and bookkeeper for a large retail corporation. Her responsibilities included processing store paperwork for corporate use, reporting daily finances to corporate office, and problem resolution.

EDUCATION

- Business Administration, United Education Institute

HIGHLIGHTS

- Proficient in Microsoft Excel, PowerPoint, Word, & Outlook, SharePoint, QuickBase, Access
- Spanish Speaker
- Knowledge of Quickbase (Temple City Permitting Software)

CERTIFICATIONS

- ICC Permit Technician

Knowledge of Building and Safety Procedures:

- Understanding, enforcing, and implementing city municipal code as well as the city's adopted building code
- Plan check submittal process and permitting process
- Communicating clearly and concisely
- Interpreting and explaining city policies and regulations to the public

Project and Task Related Experience Working in Transtech's client cities:

- Aid in resolving customer's questions and concerns regarding plan check submittal process
- Calculate and process building permits
- Complete public requests
- Organize and maintain a neat and orderly permit and plan check file
- Take inspection requests
- Provide information to applicants about status of building plan check
- Obtain all required departmental plan approvals prior to permit issuance
- Review site plans in conjunction with Business Licenses prior to sending out for Building Official's review

Administrative Building and Safety Duties

- Receives incoming plans from various cities and sorts them to be sent out to the appropriate plans examiner
- Ensure that all plans are returned in a timely manner
- Packaging plans with all proper documents (i.e. correction list, transmittal showing plans are going back to city with corrections or approved

BRITNEY ADAMS, ICC PERMIT TECHNICIAN



Ms. Adams has been with the Transtech team for over two years. She works onsite with various Transtech Contract Cities including the City of Seal Beach and City of Alhambra and serves as the Permit Technician. Some of her responsibilities include processing building permit applications and performing technical work for permit applications. She also performs clerical work that supports the operations involved with the issuance and coordination of the building inspection and permit process. Ms. Adams is constantly interacting with the general public and is the point of contact for the Building counter at the City of Seal Beach. Prior to working at Transtech, Ms. Adams holds 8 years of Cash Management, Customer Service, and Managerial experience where she supervised staff and ensured customer satisfaction.

SKILLS:

- Leadership
- Organization
- Attention to detail
- Customer Service

CERTIFICATIONS

- ICC Certified Permit Technician
- American Red Cross Certified, Adult and Pediatric First Aid/CPR/AED

EDUCATION

- High School Diploma

HIGHLIGHTS

- Microsoft Office (Word, Excel, PowerPoint, and Outlook)

Knowledge of Building and Safety Procedures:

- Procedures and techniques of permit processing and process for plan review and inspection.
- Customer Service principles and practices including conflict resolution.
- Processes for compiling and analyzing data for special projects.
- Effectively communicate clearly and concisely, both orally and in writing.
- Interpret and explain policies and regulations accurately and tactfully to the public.

EXPERIENCE:

City of Seal Beach, California
Permit Technician:

Her tasks included the following:

- Processes building permit applications
- Screens calls and refers questions to appropriate staff or department
- Records permit information into permitting software database and maintains electronic and hard file property information
- Informs project applicants of city requirements, processes, and deadlines from time of initial contact to completion of the project

City of Alhambra, California
Permit Technician:

Her tasks included the following:

- Collaborated with the Plans Examiners to respond to permit inquiries and assesses appropriate project valuations and permit fee
- Provided coverage for the division phone lines and front counter
- Served as first point of contact for customers to provide assistance with building permit policies and procedures

AARON HICKMAN, ICC PERMIT TECHNICIAN



Mr. Hickman’s experience includes working as a Permit Technician at current contract Client Cities such as the City of West Covina and City of Alhambra. Some of his major responsibilities include processing permit applications, issuing approved permits and plans, and invoicing permit and plan check fees. Mr. Hickman enjoys providing tech support to applicants and guide them on how to upload plan and plan check applications to Go Post for Plan Review. Mr. Hickman has also aided our corporate office by assisting Permit Technicians, Building Inspectors, and Plan Checkers maintain the digital file system. Additionally, he collaborates and partners with the administrative team to accomplish responsibilities in support of Transtech’s City Engineers, Project Managers and Construction Managers. Prior to working for Transtech Engineers, Mr. Hickman has 10 years of experience ensuring the success of streamlined operations.

EDUCATION

- Bachelor of Arts Degree in History, California State Polytechnic University of Pomona

CERTIFICATIONS

- ICC Certified Permit Technician

HIGHLIGHTS

- Proficient in Microsoft Excel, PowerPoint, Word, & Outlook

Skills:

- Ability to communicate in a personable manner to reach mutually agreeable solutions
- Safety and Operational awareness
- Meets deadlines and works with a high level of awareness and adaptability
- Works well under pressure and multi-tasks

Knowledge of Building and Safety Procedures:

- Coordination with City Departments
- Process Permit Applications
- Invoice permit and plan check fees
- Issue approved permits and plans
- Provide customer services and answer questions applicants and residents have on the Building Department plan check and permitting process
- Assigning applications to necessary departments
- Creating an agency referral list for applicants and verifying applicant has completed agency referral list
- Guide applicants on how to upload plan and plan check applications to Go Post Software for review
- Preserve documentation such as plan checks and submittals
- Periodic performance of inspection of files to ensure correct placement, legibility and proper condition of all files
- Delivering technical support for the B&S Department

CATALINA MENDEZ, ICC PERMIT TECHNICIAN



Ms. Mendez’s experience includes working as a Permit Technician for one of our Client Cities, City of Alhambra. Some of her major responsibilities include answering calls and emails and coordinating in person visits regarding how to obtain plan checks, permit inspections, and any other general questions. Ms. Mendez guides applicants on how to upload plans and plan check applications to Go Post for Plan Review. She is versatile in her line of work and can process applications, invoice plans, issue permits and plans, and create workflows for other departments. Ms. Mendez also assists Permit Technicians, Building Inspectors, and Plan Checkers with data input. She is also responsible for communicating with various Cities regarding Go Post submittals and completion of all required applications. Before working for Transtech Engineers, Ms. Mendez worked as an Administrator which provided her the exposure needed to effectively communicate with our Clients.

EDUCATION

- Civil Engineering – California State University Fullerton
- High School Diploma

CERTIFICATIONS

- ICC Certified Permit Technician

HIGHLIGHTS

- Proficient in Microsoft Excel, PowerPoint, Word, & Outlook
- Bi-lingual in English and Spanish
- Skilled in troubleshooting computer hardware issues

Skills:

- Outstanding communication, organization, critical thinking, and time management skills
- Creative problem solving
- Works well in stressful circumstances
- Spoken/written proficiency in English and Spanish

Knowledge of Building and Safety Procedures:

- Monitor Go Post submittals
- Assist the Building & Safety Department with data input.
- Verifies applications and permits
- Customer service: answering calls and emails, in person visits regarding how to obtain plan checks, permits inspections, and general questions.
- Processing applications on the Citizen’s Access Portal
- Invoicing plans checks via Authorize.net
- Create workflows for other departments that need to review plans on the Tyler portal
- Create an agency referral list for applicants and verify applicants have completed agency referral list.
- Guide applicants on how to upload plans and plan check applications to GoPost for plan review. Update the portal when approvals are sent.
- Invoicing permit fees
- Issue permits and plans
- Public records request
- Filing

DEBORAH PLEITEZ, ICC PERMIT TECHNICIAN



Mr. Pleitez works as a Permit Technician at several of our client cities. One of her key tasks includes monitoring plan submittal through the Go Post Portal. As a GoPost Technician she reviews applicant’s submittal before it is sent to the plan examiners. For example, she ensures that the documents uploaded verify the requirements before they are accepted. Ms. Pleitez also assist applicants who have trouble understanding how to upload into their designated portal. Ms. Pleitez provides support to the Permit Technicians, Building Inspectors, and Plan Checkers with data input. Additionally, she logs in hard copies of the daily plans received and is on the frontline of assisting in answering phone calls for the Building & Safety Department. Prior to working for Transtech Engineers Ms. Pleitez was a team lead on a project where she analyzed and developed strategies from data to help navigate budget constraints, stock flow, and expenses for a company.

EDUCATION

- Bachelor of Science, Business Administration, Accounting – California State Polytechnic University
- Associate of Science, Business Administration Accounting – Mt. Sac Antonio College

Skills:

- Able to provide high-quality service with positive experience
- Able to multitask and collaborate with management
- Exceptional communication and problem-solving skills
- Successful working in a team environment, as well as independently
- Ability to work under pressure and multi-task
- Detail-oriented with data management, bookkeeping, and general administration

CERTIFICATIONS

- ICC Certified Permit Technician

HIGHLIGHTS

- Proficient in Microsoft Excel, PowerPoint, Word, & Outlook

Knowledge of Building and Safety Procedures:

- Performs a variety of tasks and administrative duties in support of the daily operations of the Building & Safety Department.
- Data Entry on Excel
- Scans applications
- Schedules Inspections
- Maintains files
- Verifies accuracy on Go Post Portal
- Answers phone calls, responds to emails, and takes messages.
- Reviews applicant submittals
- Handles ePlans and physical plans
- Processes and ships plans



City Council Staff Report

DATE: November 16, 2022

AGENDA ITEM NO: Public Hearing - 4A

TO: The Honorable Mayor and City Council

FROM: Steve Sizemore, Interim Director of Community Development
Matt Hallock, Fire Chief

SUBJECT: Consideration and possible action to conduct a public hearing to waive further reading and adopt an Ordinance amending Titles 16 and 17 of the Monterey Park Municipal Code by adopting the 2022 Edition of The California Building Standards Code and the Monterey Park Amendments to the California Building Standards Code.

RECOMMENDATION:

It is recommended that the City Council consider:

1. Opening a public hearing and take testimonial and documentary evidence;
2. After considering the evidence, waiving the second reading. and adopting the proposed Ordinance; and
3. Taking such additional, related, action that may be desirable.

EXECUTIVE SUMMARY:

The Ordinance was introduced and received first reading at the November 2, 2022 City Council meeting. Government Code § 50022.3 requires the City Council to conduct a public hearing before conducting a second reading and approving the Ordinance because it will adopt, by reference, the 2022 California Building Standards Code, as set forth in Title 24 of the California Code of Regulations. The original staff report (from November 2, 2022) is attached for reference. Second reading and adoption of this Ordinance is recommended. If adopted, the ordinance will take effect in 30 days. If approved, the Ordinance would become effective January 1, 2023. Projects for which a building permit application and building plans were submitted before the effective date, and for which building permits are obtained within 90 days of the effective, are exempt from the updated regulations in the Ordinance. If the building permit expires, then all building plans must comply with the updated regulations.

Respectfully submitted by:



Steve Sizemore
Interim Director of Community
Development

Respectfully submitted by:



Matt Hallock,
Fire Chief

Prepared by:

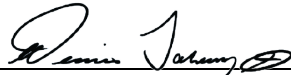

Dennis Tarango,
Acting Building Official

Approved by:

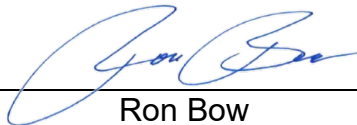

Ron Bow
City Manager

Reviewed by:

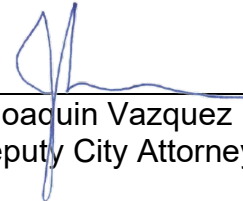

Joaquin Vazquez
Deputy City Attorney

ATTACHMENTS:

1. Ordinance and Exhibit "A" – Findings - Local Amendments to the 2022 California Building Standards Code
2. City Council Staff Report, dated November 2, 2022 (without attachments)

ATTACHMENT 1
Ordinance

ORDINANCE NO. _____

AN ORDINANCE ADOPTING THE 2022 EDITIONS OF THE CALIFORNIA BUILDING CODE, THE CALIFORNIA RESIDENTIAL CODE, THE CALIFORNIA ELECTRICAL CODE, THE CALIFORNIA MECHANICAL CODE, THE CALIFORNIA PLUMBING CODE, THE CALIFORNIA ENERGY CODE, THE CALIFORNIA HISTORICAL CODE, THE CALIFORNIA FIRE CODE, THE CALIFORNIA EXISTING BUILDING CODE, THE CALIFORNIA GREEN BUILDING STANDARDS CODE, THE CALIFORNIA REFERENCED STANDARDS CODE, THE CALIFORNIA BUILDING STANDARDS ADMINISTRATIVE CODE, MAKING CERTAIN AMENDMENTS BASED UPON LOCAL CONDITIONS; AND AMENDING THE MONTEREY PARK MUNICIPAL CODE TO REFLECT SUCH CHANGES.

The City Council for the City of Monterey Park does ordain as follows:

SECTION 1: *Findings.* The City Council finds as follows:

- A. The City may adopt model codes by reference pursuant to Government Code §§ 50022.2, *et seq.*;
- B. Health and Safety Code § 17958 requires the City to adopt certain codes that are set forth in Health and Safety Code § 17922 and published in the California Code of Regulations.
- C. In accordance with Health and Safety Code § 17958.7, it is in the public interest to adopt the most recent codes published by the California Building Standards Commission.
- D. Notice of public hearing to consider this Ordinance was duly published and posted pursuant to Government Code §§ 6066 and 50022.3 on November 3 and 10, 2022.
- E. Pursuant to Government Code § 50022.6, at least one copy of all codes adopted by reference were filed with the City Clerk and available for public inspection at least 15 days before the public hearing.
- F. Pursuant to Government Code § 50022.9, the City Council intends to adopt by reference, with local amendments, the following 2022 codes in their entirety as if set forth in full herein:
 - 1. The California Building Code, 2022 Edition - Vol. I & II as published in Title 24, Part 2 of the California Code of Regulations;
 - 2. The California Residential Code, 2022 Edition, as published in Title 24, Part 2.5 of the California Code of Regulations;
 - 3. The California Electrical Code, 2022 Edition, as published in Title 24,

Part 3 of the California Code of Regulations;

4. The California Mechanical Code, 2022 Edition, as published in Title 24, Part 4 of the California Code of Regulations;
5. The California Plumbing Code, 2022 Edition, as published in Title 24, Part 5 of the California Code of Regulations;
6. The California Energy Code, 2022 Edition, as published in Title 24, Part 6 of the California Code of Regulations;
7. The California Historical Building Code, 2022 Edition, as published in Title 24, Part 8 of the California Code of Regulations;
8. The California Fire Code, 2022 Edition, as published in Title 24, Part 9 of the California Code of Regulations;
9. The California Existing Building Code, 2022 Edition, as published in Title 24, Part 10 of the California Code of Regulations;
10. The California Green Building Standards Code, 2022 Edition, as published in Title 24, Part 11 of the California Code of Regulations;
11. The California Referenced Standards Code, 2022 Edition, as published at Title 24, Part 12, of the California Code of Regulations;

SECTION 2: In accordance with Health and Safety Code § 17958.7, the City Council finds that there are local climatic, geographic, and topographic conditions justifying the various local amendments to the California Building Standards Code as set forth in attached Exhibit “A,” which is adopted by the City Council and incorporated by reference.

SECTION 3: Monterey Park Municipal Code (“MPMC”) § 16.01.010 is amended to read as follows:

“16.01.010 Adoption of specific codes—Copies on file.

(a) Except as otherwise provided in this chapter, the following codes are adopted by reference:

1. The California Building Code, 2022 Edition - Vol. I & II as published in Title 24, Part 2 of the California Code of Regulations;
2. The California Residential Code, 2022 Edition, as published in Title 24, Part 2.5 of the California Code of Regulations;
3. The California Electrical Code, 2022 Edition, as published in Title 24, Part 3 of

the California Code of Regulations;

4. The California Mechanical Code, 2022 Edition, as published in Title 24, Part 4 of the California Code of Regulations;
5. The California Plumbing Code, 2022 Edition, as published in Title 24, Part 5 of the California Code of Regulations;
6. The California Energy Code, 2022 Edition, as published in Title 24, Part 6 of the California Code of Regulations;
7. The California Historical Building Code, 2022 Edition, as published in Title 24, Part 8 of the California Code of Regulations;
8. The California Existing Building Code, 2022 Edition, as published in Title 24, Part 10 of the California Code of Regulations;
9. The California Green Building Standards Code, 2022 Edition, as published in Title 24, Part 11 of the California Code of Regulations;
10. The California Referenced Standards Code, 2022 Edition, as published at Title 24, Part 12, of the California Code of Regulations;

(b) In accordance with Health and Safety Code Section 18942, one copy of the above-referenced codes will remain on file in the office of the city clerk.”

SECTION 4: The definition of “Code” or Codes” in MPMC § 16.01.020 is amended to read as follows:

“Code” or “codes” means the applicable version of the codes adopted by reference in this title.”

SECTION 5: Section 110.3 in MPMC § 16.01.040 is amended to read as follows:

“110.3 Required inspections. The Building Official, upon notification, must make the inspections set forth in Sections 110.3.1 through 110.3.11.”

SECTION 6: Chapter 16.05 of the MPMC is amended in its entirety to read as follows:

“Chapter 16.05 BUILDING CODE

16.05.010 Building Code adopted by reference.

Pursuant to Government Code § 50022.9, the city council incorporates by reference Chapter 1, Division I and Chapter 2 through Chapter 35 and Appendices C, F, H, I, J

and O of the California Building Code, 2022 Edition, as published in Title 24, Parts 2, Volumes 1 and 2 of the California Code of Regulations.

16.05.020 Building Code Amended

Chapter 9 and 15 of the California Building Code, 2022 Edition are amended, deleted or added as follows:

- a. Chapter 9 of the Building Code is deleted in its entirety and replaced with Chapter 9 of the California Fire Code as adopted and amended by Monterey Park Municipal Code Title 17 Fire Code.
- b. Table 1505.1 amended, by the deletion of Table 1505.1 and the addition of a new Table 1505.1 thereto, to read as follows:

TABLE 1505.1

MINIMUM ROOF COVERING CLASSIFICATIONS

TYPES OF CONSTRUCTION								
IA	IB	IIA	IIB	IIIA	IIIB	IV	VA	VB
A	A	A	A	A	A	A	A	A

- c. Section 1505.1.2 is amended to read as follows:

1505.1.2 Roof coverings within all other areas. The entire roof covering of every existing structure where more than 50 percent of the total roof area is replaced within any one-year period, the entire roof covering of every new structure, and any roof covering applied in the alteration, repair or replacement of the roof of every existing structure, will be a fire-retardant roof covering that is at least Class A.

SECTION 7: Chapter 16.06 of the MPMC is amended in its entirety to read as follows:

“Chapter 16.06 RESIDENTIAL CODE

16.06.010 Residential Code adopted by reference.

Pursuant to Government Code § 50022.9, the City Council adopts and incorporates by reference chapters 2 through 10, chapter 44 and appendices AH, AJ, AQ, and AS of the California Residential Building Code, 2022 Edition, as published in Title 24, Part 2.5 of the California Code of Regulations.

16.06.020 Residential Code Amended

Chapter 3 of the California Residential Code, 2022 Edition is amended, deleted or added as follows:

- a. Section 301.1.3.2 is amended to read as follows;

R301.1.3.2 Wood Frame Structures. Pursuant to Business and Profession Code §§ 5537 and 6737.1, construction documents must be approved and stamped by a California licensed architect or engineer for all dwellings of wood frame construction more than two stories and basement in height located in Seismic Design Category A, B, or C and more than one story in height or with a basement located in Seismic Design Category D0, D1, or D2 or E.

- b. Section R313 of the Residential Code is deleted in its entirety and replaced with Chapter 9 of the California Fire Code as adopted and amended by Monterey Park Municipal Code Title 17 Fire Code.”

SECTION 8: Section 16.07.010 of Chapter 16.07 of the MPMC is amended in its entirety to read as follows:

“16.07.010 Electrical Code adopted by reference.

Pursuant to Government Code Section 50022.9, the city council adopts and incorporates by reference the California Electrical Code and Annexes A, B, C, D, E, F, G, H, I and J, 2022 Edition, as published in Title 24, Part 3 of the California Code of Regulations.”

SECTION 9: MPMC § 16.08.010 is amended to read as follows:

“16.08.010 Mechanical Code adopted by reference.

Pursuant to Government Code § 50022.9, the city council adopts and incorporates by reference the California Mechanical Code, 2022 Edition, as published in Title 24, Part 4 of the California Code of Regulations.”

SECTION 10: MPMC § 16.09.010 is amended to read as follows:

“16.09.010 Plumbing Code adopted by reference.

Pursuant to Government Code § 50022.9, the city council adopts and incorporates by reference the California Plumbing Code, 2022 Edition, as published in Title 24, Part 5 of the California Code of Regulations.”

SECTION 11: MPMC § 16.10.010 is amended to read as follows:

“16.10.010 Energy Code adopted by reference.

Pursuant to Government Code Section 50022.9, the city council adopts and incorporates by reference the California Energy Code, 2022 Edition, as published in Title 24, Part 6 of the California Code of Regulations.”

SECTION 12: MPMC § 16.11.010 is amended to read as follows:

“16.11.010 Historical Building Code adopted by reference.

Pursuant to Government Code § 50022.9, the city council adopts and incorporates by reference the California Historical Building Code, 2022 Edition, as published in Title 24, Part 8 of the California Code of Regulations.”

SECTION 13: MPMC § 16.12.010 is amended to read as follows:

“16.12.010 Existing Building Code adopted by reference.

Pursuant to Government Code § 50022.9, the city council adopts and incorporates by reference the California Existing Building Code, 2022 Edition, as published in Title 24, Part 10 of the California Code of Regulations.”

SECTION 14: MPMC § 16.13.010 is amended to read as follows:

“16.13.010 Green Building Standards Code adopted by reference.

Pursuant to Government Code § 50022.9, the city council adopts and incorporates by reference the California Green Building Standards Code, 2022 Edition, as published in Title 24, Part 11 of the California Code of Regulations.”

SECTION 15: MPMC § 16.14.010 is amended to read as follows:

“16.14.010 Referenced Standards Code adopted by reference.

Pursuant to Government Code § 50022.9, the city council adopts and incorporates by reference the California Referenced Standards Code, 2022 Edition, as published in Title 24, Part 12 of the California Code of Regulations.”

SECTION 16: Chapters 17.01 and 17.02 of the MPMC are amended in their entirety to read as follows:

“Chapter 17.01. CALIFORNIA FIRE CODE

17.01.010 Fire Code adopted by reference.

Pursuant to Government Code § 50022.9, the City Council incorporates by reference the California Fire Code, 2022 Edition (“CFC”), as published at Title 24, Part 9, of the California Code of Regulations. The CFC, as adopted by the MPMC, includes Appendices Chapter 4, B, C, D, and O.”

“Chapter 17.02 LOCAL AMENDMENTS TO CALIFORNIA FIRE CODE

17.02.010 Amendment—Application of Residential Code.

Section 102.5 is amended to read as follows:

102.5 Application of Residential Code. Where structures are designed and constructed in accordance with the International Residential Code, the provisions of this code apply as follows:

1. Construction and designed provisions: Provisions of this code pertaining to the exterior of the structure will apply including, without limitation, premises identification, fire apparatus access and water supplies. Provisions of this code pertaining to the interior of the structure when specifically required by this code including, without limitation, Section 903 where interior or exterior systems or devices are installed, construction permits required by Section 105.6 of this code will also apply.
2. Administrative, operational, and maintenance provisions: All such provisions of this code will apply.

17.02.020 Addition—Police Powers.

Section 103.4 is added to read as follows:

103.4 Police Powers. The fire marshall and deputies have the powers of sworn police officers in performing their duties under this code. When requested to do so by the fire marshall, the chief of police of the jurisdiction is authorized to assign such available police officers as necessary to assist the fire marshall in enforcing the provisions of this code.

17.02.030 Reserved

17.02.040 Amendment—Appeals.

Section 111, including its subparts is amended in its entirety to reads as follows:

111.1 Grounds for Appeal. Any aggrieved party may appeal any of the following decisions of the Fire Chief:

1. Disapproval of any application.
2. Refusal to grant any permit applied for when it is claimed that the provisions of this California Fire Code do not apply.
3. Interpretation of this California Fire Code.
4. Determination of suitability of alternate materials or types of construction or materials to types of construction or methods.

111.2 Written Decision. Any such decision must be in writing and a copy thereof will be served upon the applicant, if any, by mail. Any such decision will be final, unless an appeal will be filed there from, within the time and in the manner prescribed by this section.

111.3 Appeal Procedure. Any person dissatisfied with any such determination or decision of the Fire Chief has the right of appeal via the Administrative Civil Review Process established under the provisions of Section 5.48.220 of this code.

17.02.050 Amendment—Definition added.

Section 202 is amended by adding the following definition:

ALL WEATHER SURFACE. A road surface constructed to the minimum standards approved by the jurisdiction capable of supporting loads of 80,000 pounds.

17.02.060 Amendment—Definitions revised.

Section 202 is amended by revising the following definitions:

“FIRE CODE OFFICIAL” means the Fire Chief or Fire Marshall, or designee, who is authorized by the Fire Chief to administer and enforce the Code.

17.02.070. Amendment—Combustible Waste Material.

Section 304.1.2 is amended to read as follows:

304.1.2 Vegetation. Weeds, grass, vines or other growth that is capable of being ignited and endangering property, must be cut down and removed by the owner or occupant of the premises. Vegetation clearance requirements in areas deemed a fire hazard by the Fire Chief or Fire Code Official must maintain a defensible space around all buildings and structures as follows:

Ground clearance. The space surrounding every building or structure must be maintained in accordance with the following:

Any person that owns, leases, controls, operates, or maintains any building or structure in, upon, or adjoining any mountainous area or forest-covered lands, brush covered lands, or grass-covered lands, or any land which is covered with flammable material, must at all times do the following:

(1) Maintain around and adjacent to such building or structure a firebreak made by removing and clearing away, for a distance of not less than 30 feet on each side thereof or to the property line, whichever is nearer, all flammable vegetation or other combustible growth. This section does not apply to single specimens of trees, ornamental shrubbery, or similar plants which are used as ground cover, if they do not form a means of rapidly transmitting fire from the native growth to any building or structure.

(2) Maintain around and adjacent to any such building or structure additional fire protection or fire-break made by removing all bush, flammable vegetation, or combustible growth which is located from 30 to 100 feet from such building or structure or to the property line, whichever is nearer, as required by the enforcing agency if he finds that, because of extra hazardous conditions, a fire break of only 30 feet around

such building or structure is not sufficient to provide reasonable fire safety. Grass and other vegetation located more than 30 feet from such building or structure and less than 18 inches in height above the ground may be maintained where necessary to stabilize the soil and prevent erosion.

17.02.080 Amendment—Open burning.

Section 307.1 is amended to read as follows:

307.1 Bonfires, Weed Abatement, Religious Burning, and Outdoor Rubbish Fires.

No person may build, light, maintain, or cause or permit to be built, lighted or maintained, any open or outdoor fire; use, or cause or permit to be used, any fire for clearing land; burn or cause or permit to be burned, any brush, trash, rubbish, stubble, or other flammable or combustible material, unless he complies with the regulations set forth in this section as follows:

1. Applicant must first secure from the Fire Chief, or designee, a written permit for such burning.
2. Such burning must be in accordance with the following:
 - a. Each recipient of a written permit for burning must follow all rules shown. Acceptance of a burning permit will constitute an agreement that the holder will be responsible for all damages resulting from burning.
 - b. Any such fire must be maintained in one small pile or area that can be readily controlled.
 - c. At least one adult person must be in actual attendance and in charge of such fire at all times during its burning. He/she must have on hand at all such times water, garden hose, shovels, or other fire extinguishing equipment.
 - d. Such burning will be permitted only at a safe distance from all structures or other combustible material.
 - e. Burning will be permitted only if there is no appreciable wind.
 - f. Upon completion of any such burning, all resultant embers must be extinguished and hot ashes must be thoroughly wet down.
3. The Fire Chief may prohibit any or all outdoor fires or burning at any time he/she deems that atmospheric conditions or local circumstances will make such a fire hazardous.

17.02.090 Reserved

17.02.100 Amendment—Automatic sprinkler systems.

Section 903 is amended as follows:

Amend Section 903.1.2 to read as follows:

903.1.2 Partial Automatic Fire Suppression Systems Prohibited.

Whenever an automatic fire suppression system is installed for any portion of any building or structure, an automatic fire suppression system must be installed for the entire building or structure.

Amend Section 903.2 to read as follows:

903.2 Where required. Approved automatic extinguishing systems must be installed:

1. In all new buildings regardless of the type of construction or occupancy.

Exceptions:

- A) Detached Group U occupancies, providing the floor area does not exceed 1000 square feet.
 - B) Unmanned facilities and/or minor buildings and/or occupancies as approved by the Fire Chief.
2. In existing buildings with an occupancy change as required by other sections of the Fire Code.

Amend Section 903.6 as follows:

903.6 Existing Occupancies. An automatic sprinkler system will be installed in existing occupancies as follows:

1. In all commercial and industrial buildings greater than 5000 square feet in area when enlarged by an addition to the existing structure or as required by the Fire Chief.
2. In all commercial and industrial buildings equal to or less than 5000 square feet in area, when enlarged by an addition to the existing structure, exceeds 5000 square feet or as required by the Fire Chief.
3. In all commercial and industrial buildings when an addition to the existing area exceeds fifty percent (50%) within any twelve-month period.
4. In all residential occupancies when an addition to the existing living area exceeds fifty percent (50%) within any twelve-month period.
5. As required by the Fire Code due to a change in occupancy.
6. As required by the Fire Code in Chapter 11.

Amend Section 903.3.1.1 as follows:

903.3.1.1 NFPA 13 sprinkler systems. In other than Group R buildings that are not over two stories in height, automatic sprinkler systems will be designed and installed in

accordance with the NFPA 13, 2022 Edition as amended in Chapter 80 except as provided in Sections 903.3.1.1.1, 903.3.1.1.2, and 903.3.1.1.3.

Add Section 903.3.1.1.4 to read as follows:

903.3.1.1.4 Riser room location. In structures over three stories in height or served by more than two fire sprinkler risers, a dedicated Fire Sprinkler Riser Room must be provided at an approved location. The riser room must be accessible to emergency personnel from the exterior of the building.

Amend Section 903.3.1.2 as follows:

903.3.1.2. NFPA 13R sprinkler systems. Where allowed in buildings of Group R, up to and including two stories in height, automatic sprinkler systems will be installed throughout in accordance with NFPA 13R, 2022 Edition as amended in Chapter 80.

Add Section 903.3.1.2.4 to read as follows:

903.3.1.2.4 Basement spaces. In residential buildings with automatic sprinkler systems designed and installed in accordance with NFPA 13R, basements used for living or storage purposes must be fully sprinklered with residential type heads.

Add Section 903.3.1.3 to read as follows:

903.3.1.3. NFPA 13D sprinkler systems. Where allowed, automatic sprinkler systems will be installed in one- and two-family dwellings will be installed throughout in accordance with NFPA 13D, 2022 Edition as amended in Chapter 80.

Add Section 903.3.1.3.1 to read as follows:

903.3.1.3.1. Detailed requirements. Automatic sprinkler system protection for one and two-family dwellings will be designed and installed in accordance with NFPA 13D, 2022 Edition with the following modifications:

1. A local water flow alarm must be provided for all sprinkler systems.
2. Attics and basements used for storage purposes must be fully sprinklered with residential type heads.
3. Overhead piping must be hydrostatically tested for leakage at 200 psi for two hours and inspected before drywall or insulation installation.
4. A minimum of three spare representative sprinkler heads and installation wrench must be provided at an approved location.

Amend Section 903.3.5 as follows:

903.3.5 Water Supplies. Water supplies for automatic sprinkler systems must comply with this section and the standards referenced in section 903.3.1. The potable water supply must be protected against backflow in accordance with the *Health and Safety*

Code and the Monterey Park Municipal Code. Hydraulic calculations for systems designed per NFPA 13, 13D, or 13R will include a ten percent (10%) reduction from the available supply source.

17.02.110 Addition—Multiple fire alarm and detection systems.

Section 907.1.6 is added to read as follows:

907.1.6 Multiple Fire Alarm Systems. Multiple fire alarm systems within single protected premises must be interconnected and must transmit signals as one system.

17.02.120 Amendment—Emergency Responder Radio Coverage

Section 1103.2 is amended to read as follows:

1103.2 Emergency responder radio coverage in existing buildings. Existing buildings that do not have approved radio coverage for emergency responders within the building based upon the existing coverage levels of the public safety communication systems of the jurisdiction at the exterior of the building, must be equipped with such coverage according to one of the following:

1. Whenever an existing wired communication system cannot be repaired or is being replaced, or where not approved in accordance with Section 5101, Exception 1.
2. Whenever total additions result in an increase of more than 6,000 square feet in the total floor area, including mezzanines or additional stories, regardless of ownership. Additions must be cumulative with each application for a building permit from January 1, 2011.
3. Whenever the value of alternations requiring permits exceed \$500,000 in valuation. Alterations values must be cumulative with each application for a building permit from January 1, 2011.

17.02.130 Amendment—Explosive materials.

Sections 5601.2 and 5601.3 are amended to read as follows:

5601.2 The manufacture, possession, storage, sale, transportation and use of explosive materials will be prohibited, unless it is authorized by the State Fire Marshal. This will not apply to hand loading of small arms ammunition for personal use when not for resale.

5601.3 Non explosive materials must be bolts, explosive rivets or cartridges for explosive-actuated power tasks in quantities involving less than 500 pounds.

17.02.140 Addition—Fireworks display.

Sections 5608.1.2 and 5608.1.3 are added to read as follows:

5608.1.2 Permits. It is unlawful for any person to present or conduct any public display of fireworks within the City of Monterey Park without first having obtained a permit there from the Fire Chief or their representative.

5608.1.3 Detailed Requirements. The public display of fireworks within the City of Monterey Park must be in accordance with Section 5608.1 of this Code and all of the following:

1. The Fire Chief is authorized to grant permits for supervised public displays of fireworks to be conducted by the city or by other organizations. Every such display must be personally supervised by a competent, licensed pyrotechnic operator approved by the Fire Chief. Each such display must be held at an approved location and must be so discharged or fired as, in the opinion of the Fire Chief after proper investigation, not to be hazardous to property or to endanger any person.
2. Applications for permit must be made in writing at least ten days in advance of the date of the display. After such permit will have been granted, the sale, possession, use, and/or distribution of fireworks for such display will be lawful for the permitted activity and time frame only. No permit granted under this code will be transferable.
3. The permittee must furnish a bond or certificate of insurance in an amount deemed adequate by the Fire Chief for the payment of all damages which may be caused either to a person or persons or to property by reason of the permitted display and arising from any acts of the permittee, agents, employees, or subcontractors.
4. When required by the Chief, the pyrotechnic operator will employ and provide additional personnel whose sole duty will be the enforcement of crowd control around the display area. Unauthorized persons will not be allowed to enter the discharge site until the site has been inspected and cleared after conclusion of the display by the pyrotechnic operator.
5. The Fire Chief is authorized to require rope barriers, fences, signs or other devices to be installed around the display area to aid in crowd control.
6. The Fire Chief is authorized to adopt such additional rules and regulations not inconsistent herewith as are reasonably required to prevent injury to persons and/or property, including without limitation the requirement for standby fire personnel or apparatus at the firing site.
7. If the Fire Chief or appointed designee determines that there is a lack of crowd control or that the crowd is in danger, the display will be immediately discontinued. If at any time high winds or wet weather creates a danger, the display will be postponed until weather conditions are acceptable to the Chief.
8. The entire firing site must be inspected immediately following a display and before allowing public access for the purpose of locating unexploded aerial shells and/or hazardous debris. Unexploded shells will not be handled within 15 minutes after the time of their firing. Such shells must then be doused thoroughly with water, allowed to stand for at least 5 minutes, and then be submersed in a full bucket of water.

17.02.150 Addition—Fireworks manufacturing.

Section 5614 is added to read as follows:

**SECTION 5614
FIREWORKS MANUFACTURING**

5614.1 It is unlawful to manufacture fireworks within the City of Monterey Park.

5614.2 The Fire Chief is authorized to seize, take, remove or cause to be removed, at the expense of the owner, all stocks of fireworks or explosives offered or exposed for sale, or stored or held in violation of this section.

17.02.160 Addition—Sale of fireworks.

Section 5615 is added to read as follows:

**SECTION 5615
SALE OF FIREWORKS**

5615.1 Sales of Fireworks. The sale of “Safe and Sane” fireworks within the City of Monterey Park city limits will be in accordance with ~~Section 3301 of the Code~~, Chapter 5.48 of the Monterey Park Municipal Code, and all of the following:

5615.1.1 It is unlawful for any person to sell, or to cause or permit to be sold, within the city, any fireworks at retail without first securing a permit to do so from the Fire Chief. A separate permit must be obtained for each separate or distinct place of business or stand. Any person having a permit, who fails to comply with the conditions of the permit as provided for by this section, will be deemed to be operating without a permit. Application must be made no earlier than April 1 and no later than May 15 of each calendar year.

5615.1.2 The maximum number of permits, which may be issued will be (20) during any one calendar year.

If the number of applications exceed the number of permits to be issued, the permittees, who did not violate any requirements of this chapter during the preceding year, will have first priority for the available permits until April 15, provided each permittee represents the same participating organization which operated under the permit during the preceding year.

If there are any additional permits available, such additional permits will be granted by a drawing supervised by the license officer, or other municipal officer designated by the City Council.

1. The following qualifications must be met by each application for a permit:
 - a. No permit will be issued to any person, firm, or corporation, except any veterans organization or any auxiliary of such organization chartered by the Congress of the United States, maintaining a charter and meeting place in the City whose membership is composed of members now and/or heretofore serving in the armed forces of the United States; or, any nonprofit associations or corporations organized primarily for civic betterment or youth activities, charitable, or religious purposes.

- b. Each such organization must have its principal and permanent meeting place within the city limits of Monterey Park, and must have been organized and established within the city limits of Monterey Park, and must have been organized and established within such city limits for a minimum of one year continuously preceding the filing of an application for a permit.
 - c. No organization may receive more than one permit for fireworks sales during any one calendar year.
 - d. No stand will be within 500 feet of another stand.
2. Each applicant for a permit must take out and maintain in force, while any such fireworks stand is open, public liability insurance in an amount of not less than \$1,000,000 for injury to one person, and not less than \$1,000,000 for any one occurrence, and one million dollars (\$1,000,000) for damage to property. The City of Monterey Park must be named as “additional insured” on all policies required hereunder. Before the issuance of a permit hereunder, each applicant must furnish evidence satisfactory in form and substance to the city that such insurance is in force, and adequate legal assurance that the carrier will give the city at least thirty days’ prior written notice of the cancellation of the policy, during the effective period of the permit.
 3. Applicants for a permit hereunder must pay a permit fee in accordance with the City of Monterey Park Master Schedule of Fees and Charges for each fireworks stand.
 4. It will be unlawful for any person to sell at retail “dangerous fireworks,” as defined in the California State Fireworks Law.
 5. No “safe and sane” fireworks, as defined in the California State Fireworks Law, will be sold or offered for sale at retail within the City, except from 12:00 noon on June 28 to 9:00 p.m. on July 4 of each year. In addition, the discharge of fireworks is limited to 10 a.m. to 10 p.m. on only July 4.
 6. No “safe and sane” fireworks will be sold or offered for sale at retail unless the fuses or other igniting devices are protected by approved protective caps, or each item or group of items is enclosed or sealed in a package bearing the California State Fire Marshal’s Seal of Registration, upon which the wholesaler’s license number appears.
 7. The Fire Chief is authorized to promulgate reasonable additional rules and regulations for the operation of fireworks stands, in order to eliminate or reduce to a minimum the risk of fire or injury to persons or damage to property. A copy of any such rules and regulations must be posted in a prominent place in each fireworks stand. Failure to comply with said rules and regulations will be grounds for the immediate revocation of any permit granted under this section.

17.02.170 Amendment—Locations where aboveground tanks are prohibited.

Section 5704.2.9.6.1 is amended to read as follows:

5704.2.9.6.1 The storage of Class I and II liquids in above ground tanks outside of buildings is prohibited within the limits established by law as the limits of districts in which such storage is prohibited.

1. Class I and II liquids must be stored in above ground tanks outside of buildings only at locations in the city zoned or used for Manufacturing purposes, as designated in the Monterey Park Municipal Code and the zoning map of the City of Monterey Park.
Exception: Above ground storage tanks dispensing Class I and II liquids will not be allowed in motor fuel service stations.
2. The storage of Class I and II liquids in above ground tanks may be permitted in other zones if the Fire Chief finds that such use in a particular installation will not create an unreasonable risk of injury to person or property after consideration of special factors; such as, topographical conditions, nature of occupancy and proximity to buildings or adjoining property, and height and character of construction of such buildings, capacity and construction of proposed tanks and character of liquids to be stored, degree of private fire protection to be provided, and facilities of the Fire Department available to cope with flammable or combustible liquid fires.

17.02.180 Amendment—Liquefied petroleum gases—Location of containers.

Section 6104.2 is amended to read as follows:

6104.2 Liquefied petroleum gas may be stored only at locations zoned or used for Manufacturing Development purposes, as designated in the Monterey Park Municipal Code and the zoning map of the City of Monterey Park.

Such storage, however, may be permitted in other zones if the fire code official finds that such use in a particular installation will not create an unreasonable risk of injury to person or property, after consideration of the special features; such as, topographical conditions, nature of occupancy and proximity to building or adjoining property and height and character of construction of such buildings, capacity and construction of proposed tanks, and character of liquids to be stored, degree of private fire protection to be provided, and facilities of the Fire Department to cope with flammable or combustible liquid fires.

17.02.190 Amendment—Appendix Chapter D Dead ends.

Section D103.4 of Appendix Chapter D is amended to read as follows:

D103.4 Dead Ends. Dead-end fire apparatus access roads in excess of 150 feet must be provided with width and turnaround provisions to the minimum standards adopted by the jurisdiction.

17.02.200 Amendment — Appendix Chapter O Haunted Houses

Section O101.2 of Appendix Chapter O is amended to read as follows:

O101.2 Permits. An operational permit must be required for haunted houses, ghost walks, or similar amusement uses in accordance with Appendix O101.2.

EXCEPTION: Haunted houses, ghost walks, or similar amusement uses in Group R-3 occupancies.”

SECTION 17: ***Construction.*** This Ordinance must be broadly construed in order to achieve the purposes stated in this Ordinance. It is the City Council’s intent that the provisions of this Ordinance be interpreted or implemented by the City and others in a manner that facilitates the purposes set forth in this Ordinance.

SECTION 18: ***Enforceability.*** Repeal of any provision of the Monterey Park Municipal Code does not affect any penalty, forfeiture, or liability incurred before, or preclude prosecution and imposition of penalties for any violation occurring before this Ordinance’s effective date. Any such repealed part will remain in full force and effect for sustaining action or prosecuting violations occurring before the effective date of this Ordinance.

SECTION 19: ***Validity of Previous Code Sections.*** If this entire Ordinance or its application is deemed invalid by a court of competent jurisdiction, any repeal or amendment of the MPMC or other city ordinance by this Ordinance will be rendered void and cause such previous MPMC provision or other the city ordinance to remain in full force and effect for all purposes.

SECTION 20: ***Environmental Assessment.*** The City Council finds that adoption of this Ordinance is exempt from review under the California Environmental Quality Act (Public Resources Code §§ 21000, *et seq.*, “CEQA”) and the regulations promulgated thereunder (14 California Code of Regulations §§ 15000, *et seq.*, the “CEQA Guidelines”) because it consists only of minor revisions and clarifications to an existing code of construction-related regulations and specification of procedures related thereto and will not have the effect of deleting or substantially changing any regulatory standards or findings required therefor, and therefore does not have the potential to cause significant effects on the environment. In addition, this ordinance is an action being taken for enhanced protection of the environment and is exempt from further review under CEQA Guidelines § 15308.

SECTION 21: ***Severability.*** If any part of this Ordinance or its application is deemed invalid by a court of competent jurisdiction, the city council intends that such invalidity will not affect the effectiveness of the remaining provisions or applications and, to this end, the provisions of this Ordinance are severable.

SECTION 22: ***Publication.*** The City Clerk is directed to certify the passage and adoption of this Ordinance; cause it to be entered into the City of Monterey Park’s book of original ordinances; make a note of the passage and adoption in the records of this meeting; and, within 15 days after the passage and adoption of this Ordinance, cause it to be published or posted in accordance with California law.

SECTION 23: ***Effective Date.*** This Ordinance will become effective on January 1,

2023. Projects for which a building permit application and building plans were submitted before the effective date of this Ordinance, and for which building permits are obtained within 90 days from the effective date of this Ordinance, are exempt from the regulations in the 2022 code update including the codes adopted by reference in this Ordinance. Should, however, the building permit expire, all building plans must comply with this Ordinance.

SECTION 24: ***Filing with Building Standards Commission.*** The City Clerk must file a certified copy of this Ordinance with the California Building Standards Commission.

PASSED AND ADOPTED at a regular meeting of the City Council of the City of Monterey Park, held on the 16th day of November, 2022.

Henry Lo, Mayor

ATTEST:

Vincent D. Chang, City Clerk

I HEREBY CERTIFY that the above and foregoing ordinance was duly passed and adopted by the Monterey Park City Council at its regular meeting held on 16th day of November, 2022, by the following vote, to wit:

AYES;
NOES;
ABSENT:

APPROVED AS TO FORM:
KARL H. BERGER, CITY ATTORNEY

By: _____
Joaquin Vazquez, Deputy City Attorney

**Findings - Local Amendments
To The
2022 California Models Codes**

The City Council finds as follows:

SECTION 1: Pursuant to the requirements of Health and Safety Code §17958.7, the City Council finds that there are local climatic, geographic, and topographic conditions justifying the various local amendments to the California Model Codes as set forth herein.

SECTION 2: Specifically, the City Council finds:

A. Climatic Conditions

1. The City of Monterey Park is a densely populated area within a climate system capable of producing major winds, fire and rain related disasters, including but not limited to those caused by the Santa Ana winds and El Niño (or La Niña) subtropical-like weather. This region is especially susceptible to more active termite and wood attacking insects and microorganisms.
2. Hot, dry Santa Ana winds are common to all areas within the City of Monterey Park. These winds, which can cause small fires which spread quickly, are a contributing factor to the high fire danger in the area, and create the need for an increased level of fire protection. This added protection will supplement normal fire department response available and provide immediate protection for life and safety of multiple occupancy occupants during fire occurrences.
3. Los Angeles County and the City of Monterey Park are located in a semi-arid Mediterranean type climate which predisposes all fuels, including wood shingles to rapid ignition and spread of fire. Therefore, there exists a need for additional fire protection measures.
4. The warm, dry climate is conducive to swimming pools which creates a higher probability of child drowning where pools are unprotected.

B. Geological Conditions

1. The City of Monterey Park is a densely populated area having buildings and structures constructed over and near a vast array of fault systems capable of producing major earthquakes, including but not limited to the 1994 Northridge Earthquake, the 1987 Whittier

Narrows Earthquake, the 1971 San Fernando Earthquake and the 1933 Long Beach Earthquake.

2. The October 17, 1989, Santa Cruz earthquake resulted in only one major San Francisco fire in the Marina district. But, when combined with the 34 other fires and over 500 responses, the department was taxed to its full capabilities. The Marina fire was difficult to contain because mains supplying water to the district burst during the earthquake. If more fires had been ignited by the earthquake, it would have been difficult for the fire department to contain them. This situation creates the need for both additional fire protection measures and automatic on-site fire protection for building occupants since a multitude of fires may result from breakage of gas and electric lines as a result of an earthquake. As noted by "Planning Scenario on a Major Earthquake Department on of the Newport-Inglewood Fault Zone, 1988, State Conservation," "unfortunately meeting the minimum earthquake standards of building codes barely places a building on the verge of being legally unsafe."
3. Traffic and circulation congestion presently existing in the City of Monterey Park often challenges fire department response times. This condition will be exacerbated by any major disaster, including any earthquake wherein damage to the highway system will occur. This condition makes the need for additional on-site protection for property occupants necessary.
4. Placement of multiple occupancy buildings, location of arterial roads, and fire department staffing constraints due to recent revenue-limiting state legislation have made it difficult for the fire department to locate additional fire stations and provide manpower sufficient to concentrate fire companies and personnel to control fires in high density apartment or condominium buildings. Fire Department equipment does not allow easy access to areas of buildings greater than 55 feet above the level of Fire Department vehicle access. These conditions create the need for built-in onsite fire protection systems to protect occupants and property until firefighting apparatus and personnel arrive on the scene.
5. The City of Monterey Park is located in an area subject to a climatic condition of high winds and low humidity. This combination of events creates an environment which is conducive to rapidly spreading fires. Control of such fires requires rapid response. Obstacles generated by a strong wind, such as fallen trees, street lights and utility poles, and the requirement to climb 75 feet vertically up flights of stairs will greatly impact the response time to reach an incident scene. Additionally, ASCE-7, Section 6, Figure 6 - 2 Height Adjustment

Table identifies a significant increase in the amount of wind force at 60 feet above the ground. Use of aerial type firefighting apparatus above this height would place rescue personnel at increased risk of injury.

6. The City of Monterey Park is located in the middle of a seismically active area. The viability of the public water system would be questionable at best after a major seismic event. This would leave tall buildings vulnerable to uncontrolled fires due to a lack of available water and an inability to pump sufficient quantities of any available water to floors above the 55-foot level. A severe seismic event has the potential to negatively impact any rescue or fire suppression activities because it is likely to create obstacles similar to those indicated under the high wind section above. With the probability of strong aftershocks, there exists a need to provide increased protection for anyone on upper floors.
7. Untreated wood roofs cause or contribute to serious fire hazard and to the rapid spread of fires when such fires are accompanied by high winds. Pieces of burning wooden roofs become flying brands and are carried by the wind to other locations and thereby spread fire quickly.

C. Topographic Conditions

1. The City of Monterey Park is in an area that has a high percentage of structures on hillsides. Access for fire or rescue response and staging for firefighting are made challenging and difficult due to the terrain.

SECTION 3: Because of the local climatic, geologic and topographic conditions, the following local amendments are needed:

2022 California Building Code

Code Section	Finding
Chapter 9	A-1, A-2, B-4, C-1
Table 15.05.1	A-1, A-2, B-4, C-1

2022 California Residential Code

Code Section	Finding
Section R301.1.3.2	B-1
Section R313	A-1, A-2, B-4, C-1

2022 California Fire Code

Code Section	Finding
102.5	Administrative

103.4	Administrative
111	Administrative
202	Administrative
304.1.2	A,B,C
307.1	A,B,C
903	A,B,C
907.1.6	A,B,C
1103.2	A,B,C
5601	A,B,C
5608	A,B,C
5614	A,B,C
5615	A,B,C
5704.2.9.6.1	A,B,C
6104.2	A,B,C
D103.4	A,B,C
O101.2	A,B,C

ATTACHMENT 2

City Council Staff Report, November 2, 2022
(without attachments)



City Council Staff Report

DATE: November 2, 2022

AGENDA ITEM NO: New Business - 5A

TO: The Honorable Mayor and City Council

FROM: Steve Sizemore, Interim Director of Community Development
Matt Hallock, Fire Chief

SUBJECT: Consideration and possible action to read by title only, waive further reading, and introduce Ordinance amending Titles 16 and 17 of the Monterey Park Municipal Code by adopting the 2022 Edition of The California Building Standards Code and the Monterey Park Amendments to the California Building Standards Code; set public hearing for November 16, 2022.

RECOMMENDATION:

It is recommended that the City Council consider:

1. Reading by title only, waiving further reading, and introducing the proposed Ordinance;
2. Scheduling a public hearing on November 16, 2022 for the second reading and adoption of the Ordinance; and/or
3. Taking such additional, related, action that may be desirable.

EXECUTIVE SUMMARY:

Every three years, the State of California adopts new uniform codes that apply to all jurisdictions within California. These are codified in Title 24 of the Code of California Regulations and are commonly referred to as "uniform codes" or the California Building Standards Code ("CBSC"). The 2022 CBSC takes effect on January 1, 2023. California law allows local governments to make limited amendments to the CBSC based upon local climatic, topographical, and geological conditions, or for administrative reasons.

If adopted, the proposed Ordinance would incorporate the uniform codes by reference into the MPMC. Additionally, the Ordinance would make limited amendments to these regulations based upon local conditions.

CEQA (California Environmental Quality Act):

Pursuant to the California Environmental Quality Act ("CEQA") and the CEQA Guidelines, the proposed Ordinance affects commercial development or businesses and is not subject to further review under CEQA for the following reasons: (1) the Ordinance is an action being taken for enhanced environmental protection (14 Cal. Code Regs. § 15308); (2) there is no possibility that the ordinance may have a significant effect on the environment (14 Cal. Code Regs. § 15061(b)(3)); and (3) it will

not result in a direct or reasonably foreseeable indirect physical change in the environment (14 Cal. Code Regs. § 15060(c)(2)). The notice of exemption prepared for this project is contained in Attachment 2.

TYPE OF ACTION (LEGISLATIVE)

The recommended action is to amend MPMC Titles 16 and 17 by adopting the 2022 Edition of the CBSC. In considering such action, the City Council acts in its discretionary legislative capacity (formulating rules that apply to all future cases). For the proposed amendments, the City Council must find that they are reasonably necessary because of local climatic, geological or topographical conditions (Health and Safety Code § 17958.7). These findings, and the facts upon which they rely, are included within the draft Ordinance.

BACKGROUND:

The California Building Standards Commission is authorized by Health and Safety Code §§ 18901 through 18949.31 to administer the processes governing to adoption, approval, publication, and implementation of California's uniform codes every three years.

These uniform codes – which are codified in Title 24 to the California Code of Regulations – constitute a compilation of different types of criteria from three sources:

- Building standards that are adopted by state agencies with change from building standards contained in national model codes;
- Building standards that are adopted and adapted from the national model code standards to meet California conditions; and
- Building standards, authorized by the California legislature, that constitute extensive additions not covered by the model codes that have been adopted to address particular California concerns.

An example of a uniquely California requirement would be earthquake readiness. Altogether, 2022 Edition of the California Building Standards Code (CBSC) includes the following:

1. The California Building Code, 2022 Edition - Vol. I & II as published in Title 24, Part 2 of the California Code of Regulations;
2. The California Residential Code, 2022 Edition, as published in Title 24, Part 2.5 of the California Code of Regulations;
3. The California Electrical Code, 2022 Edition, as published in Title 24, Part 3 of the California Code of Regulations;
4. The California Mechanical Code, 2022 Edition, as published in Title 24, Part 4 of the California Code of Regulations;

5. The California Plumbing Code, 2022 Edition, as published in Title 24, Part 5 of the California Code of Regulations;
6. The California Energy Code, 2022 Edition, as published in Title 24, Part 6 of the California Code of Regulations;
7. The California Historical Building Code, 2022 Edition, as published in Title 24, Part 8 of the California Code of Regulations;
8. The California Existing Building Code, 2022 Edition, as published in Title 24, Part 10 of the California Code of Regulations;
9. The California Green Building Standards Code, 2022 Edition, as published in Title 24, Part 11 of the California Code of Regulations; and
10. The California Referenced Standards Code, 2022 Edition, as published at Title 24, Part 12, of the California Code of Regulations.

California law does allow each local jurisdiction to make limited amendments to the CBSC to govern unique issues within that jurisdiction. For example, coastal cities may make changes to address coastal erosion. In Monterey Park, the primary issues are fire prone open and inhabited areas, combined with steep topography, and seasonal high winds. Additionally, like virtually every other jurisdiction in California, the City must be prepared for earthquake activity. To address these local challenges, the proposed Ordinance makes local amendments to the CBSC.

Since the City is incorporating the CBSC into the Monterey Park Municipal Code (“MPMC”), Government Code § 5002.3 requires that the City Council conduct a public hearing before adopting the Ordinance. Accordingly, if the Ordinance is introduced, a public hearing would be noticed for the November 16, 2022 City Council meeting.

The City Council should also be aware that there are several project applications that are being reviewed by the City. It is unclear whether the City will issue building permits before the end of 2022 for these projects. Pursuant to the overall objective of the 2020 Monterey Park Business Recovery Program – which is to facilitate construction to boost economic health within the City – the Ordinance would allow pending project applications to comply with the 2019 uniform codes if the City issues a building permit for those projects by April 1, 2023 (90 days from January 1, 2023). Without that provision, all projects would need to comply with the CBSC on January 1, 2023. That could result in a significant delay (and cost) to developers applying for building permits based upon the 2019 uniform codes.

FISCAL IMPACT:

There no identifiable fiscal impacts associated with adopting the Ordinance and Resolution (other than administrative costs associated with codifying the Ordinance).

Respectfully submitted by:



Steve Sizemore
Interim Director of Community
Development

Respectfully submitted by:



Matt Hallock,
Fire Chief

Prepared by:

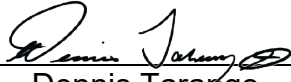

Dennis Tarango,
Acting Building Official

Approved by:

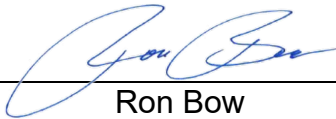

Ron Bow
City Manager

Reviewed by:



Joaquin Vazquez
Deputy City Attorney

ATTACHMENTS:

1. Ordinance and Exhibit "A" – Findings - Local Amendments to the 2022 California Building Standards Code
2. Notice of Exemption



City Council Staff Report

DATE: November 16, 2022

AGENDA ITEM NO: Public Hearing - 4B

TO: The Honorable Mayor and City Council
FROM: Steve Sizemore, Interim Director of Community Development
SUBJECT: Public Hearing and Consideration of adopting a Resolution Amending the 2021-2029 Housing Element (GPA 22-02) to the Monterey Park General Plan effective January 19, 2022

RECOMMENDATION:

It is recommended that the City Council consider:

1. Opening the public hearing to receive testimonial and documentary evidence;
2. After closing the public hearing and considering the evidence, adopt a Resolution amending the Monterey Park Housing Element effective January 19, 2022;
3. Authorize the City Manager, or designee, to prepare and transmit the final documents to the California Department of Housing and Community Development ("HCD"); and
4. Take such additional, related, action that may be desirable.

CALIFORNIA ENVIRONMENTAL QUALITY ACT ("CEQA"):

The draft Resolution amends the City's Housing Element ("HE") that was adopted January 19, 2022. There are no significant, substantive, amendments to the HE that would result from adopting the Resolution. Consequently, the findings and conclusions of Resolution No. 2022-R2 are incorporated into the draft Resolution; no additional environmental findings are required.

EXECUTIVE SUMMARY:

If adopted, the proposed Resolution would amend the previously adopted Housing Element effective January 19, 2022 ("HE"). The proposed amendment is recommended at the request of the California Department of Housing and Community Development ("HCD") to secure certification of the City's HE. These changes are primarily technical; there are no significant, substantive, amendments to the HE proposed in the draft Resolution.

BACKGROUND:

The City Council adopted the HE in January 2022. Thereafter, the City forwarded the HE to HCD for review and certification.

After reviewing the HE, HCD requested certain changes to the HE. One notable HCD comment was its assertion that the City's HE relies upon non-vacant sites to

accommodate more than 50 percent of the City's RHNA obligations for lower-income households. Consequently, HCD seeks to have the City Council make findings that the existing uses on such properties do not impede additional residential development and will likely stop during the HE's planning period, i.e., between 2021 and 2029.

The HE currently identifies potential capacity for more residential development. It relies upon geospatial data to identify potential sites within the City for such housing. Non-vacant parcels are currently identified in the HE as sites likely to be redeveloped during the next eight years based on the following site selection criteria:

- Improvement-to-Land Value
- Existing use vs. zoned use
- Age of structure
- Ownership patterns
- Likelihood of redevelopment
- Community input
- Floor Area Ratio Standards

The Monterey Park Land Use Element ("LUE") permits higher density residential zones to occur in the northern portion of the City in the North Garfield area and along the Garvey Corridor ("North Garfield Area"). In addition to the specific parcel analysis described above, the amended HE prioritizes redevelopment in the North Garfield Area, specifically for mixed-use and affordable housing projects. Additionally, the HE incorporates programs intended to conserve existing housing, remove barriers to housing development, and assist in developing affordable housing, specifically targeting the North Garfield Area.

Since the City relies on non-vacant sites to accommodate more than 50 percent of its RHNA for lower-income households, California law presumes that the non-vacant sites' existing use would impede additional residential development. To overcome this presumption, the HE selected sites that provide the best opportunities to add significant numbers of affordable housing units to the City's housing stock and have the highest potential for becoming available for residential development. Among other things, for sites with existing residential use, sites were only included if they were large enough to net at least two additional units.

Non-vacant sites with residential and non-residential uses are prioritized in the HE on the Sites Inventory if the existing structure are older, if the floor area ratio is low, and if the improvement-to-land value ratio is less than one. The City prioritizes a mix of residential units in the North Garfield Area due to its healthy environment, available utilities, high access to economic and education opportunities, and close proximity to transit.

Current planned or approved residential projects are in the North Garfield Area, demonstrating that the North Garfield Area has high development potential. Additionally,

as part of the City's public outreach effort, members of the public identified the North Garfield Area as the most desirable location for future housing sites.

An additional factor considered by the HE is reusing currently developed sites for residential housing, the so-called "recycling." A recycling option may be desirable when lack of housing supply and high rent suggests that existing land uses crowd out residential development. Such recycling options are more likely to occur on land zoned for mixed-use development. Development data show that a significant majority of mixed-use zoned projects have a significant residential component. Consequently, the HE that future residential development will continue in areas zoned mixed-use to accommodate both residential and non-residential uses. The City will work to continue this trend by facilitating the development of mixed-use projects by offering development incentives and working with developers to discuss housing development opportunities in areas designated for mixed-use (HE, Program 11). Additionally, the City will promote affordable housing development in the high resource areas of the City. Indeed, the City Council already considered (on November 2, 2022) a draft Inclusionary Housing Program which, if adopted, would help encourage development of affordable units in the City (HE, Program 15). The HE provides that the City will also continue to engage local property owners to discuss redevelopment opportunities on their properties. Based on this analysis and future efforts undertaken through the Housing Plan, the City concludes that existing uses will not impede additional residential development and all sites identified in this Housing Element are adequate to accommodate the RHNA.

Should the City Council adopt the attached resolution, staff will resubmit the Element to HCD and it will have 60 days to review the document. It is anticipated that the City will have a certified Housing Element in early 2023.

Respectfully submitted by:



Steve Sizemore
Interim Community Development
Director

Approved by:



Ron Bow
City Manager

Reviewed by:

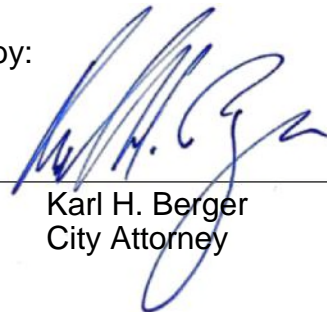

Karl H. Berger
City Attorney

ATTACHMENTS:

1. Draft Resolution

ATTACHMENT 1
Resolution

RESOLUTION

A RESOLUTION RETROACTIVELY AMENDING THE 2021-2029 HOUSING ELEMENT (GPA 22-02) OF THE MONTEREY PARK GENERAL PLAN

The City Council of the City of Monterey Park does resolve as

follows: SECTION 1. The City Council finds and declares that:

- A. Following a public hearing held on January 19, 2022, the City Council adopted Resolution No. 2022-R3 which added the 2021-2029 Housing Element to the Monterey Park General Plan (the “Housing Element”).
- B. Separately, the City Council adopted Resolution No. 2022-R2 on January 19, 2022 which constitutes the City’s environmental review of the Housing Element.
- C. After being adopted, the Housing Element was posted on the City's website and a link emailed to all individuals and organizations that previously requested notices. Additionally, the Housing Element was submitted to the California Department of Housing and Community Development (“HCD”) on February 2, 2022.
- D. After reviewing the Housing Element, HCD requested certain changes be made to the Housing Element in order for the City to obtain HCD certification in accordance with California law.
- E. After reviewing the requested changes, the Interim City Planner made proposed changes to the Housing Element for City Council consideration. Because of its volume, the Housing Element is available for public review at

<https://www.montereypark.ca.gov/DocumentCenter/View/13724/Housing-Element-Changes-Consolidated>

While not attached to this Resolution as an exhibit, the amended Housing Element is nevertheless incorporated by reference as if fully set forth.

- F. The Interim City Planner completed review and scheduled a public hearing regarding the Project before the City Council for November 16, 2022. Notice of the public hearing was posted and mailed as required by the Monterey Park Municipal Code (“MPMC”);
- G. On November 16, 2022, the City Council opened the public hearing to

receive public testimony and other evidence regarding the proposed Project including, without limitation, information provided to the City Council by City staff and public testimony;

- H. This Resolution and its findings are made based upon the entire administrative record including, without limitation, testimony and evidence presented to the City Council at its January 19, 2022 and November 16, 2022 public hearings including, without limitation, the staff report submitted by the Interim City Planner.

SECTION 2. Planning Agency. Pursuant to MPMC § 2.56.020(A), the City Council will act as the Monterey Park Planning Agency for purposes of considering the Housing Element.

SECTION 3. Amendment to Resolution No. 2022-R3. This Resolution is intended to, and does, amend Resolution No. 2022-R3. Should there be any conflict with this Resolution and Resolution No. 2022-R3, this Resolution will prevail. Except as amended by this Resolution, all Sections of Resolution No. 2022-R3, including Section 4 as to Environmental Assessment, remain in full force and effect.

SECTION 4. Retroactivity and Legislative Actions. The City Council finds as follows:

- A. The City Council intends that this Resolution be retroactively in effect to January 19, 2022. In doing so, the City Council recognizes that California law, including, without limitation, *Melton v. City of San Pablo* (1967) 252 Cal.App.2d 794 and *In re Cindy B. v. Eugene B.* (1987) 192 Cal.App.3d 771, allows legislative actions to be retroactively applied when the legislative intent for such retroactivity is clear. Additionally, the City Council notes that it may interpret its own regulations as recognized in California law including, without limitation, *Yamaha Corp. of Am. v State Bd. of Equalization* (1998) 19 Cal.4th 1 and *State Farm Mutual Auto Ins. Co. v Quackenbush* (1999) 77 Cal.App.4th 65.
- B. In retroactively amending the Housing Element as set forth in this Resolution, the City Council recognizes that it may not bind the legislative decision-making of future City Councils: “[i]t is the general rule that one legislative body cannot limit or restrict its own power or that of subsequent Legislatures and that the act of one Legislature does not bind its successors.” *Mueller v. Brown* (1963) 221 Cal.App.2d 319 (quoting *In re Collie* (1952) 38 Cal.2d 396, 398); *Thompson v. Board of Trustees* (1904) 144 Cal. 281; *McNeil v. City of South Pasadena* (1913) 166 Cal. 153. Indeed, not even a court of competent jurisdiction may do so. See, e.g., *Scott v. Common Council of City of San Bernardino* (1996) 44 Cal.App.4th 684; *Visalia School Dist. v. W.C.A.B.* (1995) 40 Cal.App.4th 1211; *U.S. v. National Treasury Employees Union* (1995) 115 S.Ct. 1003; *Friends of H*

St. v. City of Sacramento (1993) 20 Cal.App.4th 152; *Sklar v. Franchise Tax Bd.* (1986) 185 Cal.App.3d 616; *Fontana Unified School Dist. v. City of Rialto* (1985) 173 Cal.App.3d 725; *Hicks v. Bd. of Supervisors* (1977) 69 Cal.App.3d 228; *Bd. of Supervisors v. California Highway Commission* (1976) 57 Cal.App.3d 952; *Wilson v. Hidden Valley Municipal Water District* (1967) 256 Cal.App.2d 271. Consequently, all references in the Housing Element that otherwise appear to commit the City Council to a particular course of legislative action only commit the City to placing matters onto the City Council agenda for consideration and possible action. Nothing, however, commits the City to adopting any legislative regulation in any particular manner or at all. Such language is included in the Housing Element at the insistence of HCD for purposes of certifying the Housing Element.

SECTION 5. *Factual Findings and Conclusions.* The City Council finds that the following facts exist and makes the following conclusions:

- A. As noted comprehensively within the Housing Element, the City solicited public input for over a period of 18 months;
- B. Additionally, the City sought review and comment from HCD as contemplated by the California Legislature and required by California law. A draft of the amended HE was provided to HCD on October 27, 2021;
- C. The Housing Element relies on vacant and non-vacant sites to meet the City's RHNA obligation. Pursuant to Government Code § 65583.2, the City Council finds that the existing uses on the identified non-vacant are not an impediment to additional residential development. Property owners of the non-vacant sites identified in the Housing Element have expressed keen interest in housing and have discussed with planning staff, opportunities to redevelop their properties with higher densities. Further, due to increases in housing rental prices, housing affordability and implementation of the Land Use Element programs make underutilized properties more desirable, the existing uses are likely to discontinue in whole or part during the 2021-2029 planning period, accommodating the additional units identified in the Housing Element.

SECTION 6. *Environmental Assessment.* The findings and conclusions of Resolution No. 2022-R2, adopted January 19, 2022, are incorporated by reference. As set forth in that Resolution, the Addendum fully analyzes the environmental impacts of the Project for purposes of CEQA.

SECTION 7. *Approval.* The City Council approves the Housing Element. If required by law, the City Manager, or designee, is directed to submit the Project to the State of California for certification.

SECTION 8. Delegation of Authority. The City Manager is authorized to make clerical corrections; minor technical changes; and other non-substantive edits to the Housing Element, in a form approved by the City Attorney, to ensure the Housing Element receives final certification from the State of California. Unless substantive changes are required, no additional City Council action is required to ratify such changes.

SECTION 9. Reliance on Record. Each and every one of the findings and determinations in this Resolution are based on the competent and substantial evidence, both oral and written, contained in the entire record relating to the project. The findings and determinations constitute the independent findings and determinations of the City Council in all respects and are fully and completely supported by substantial evidence in the record as a whole.

SECTION 10. Limitations. The City Council's analysis and evaluation of the project is based on the best information currently available. It is inevitable that in evaluating a project that absolute and perfect knowledge of all possible aspects of the project will not exist. One of the major limitations on analysis of the project is the City Council's lack of knowledge of future events. In all instances, best efforts have been made to form accurate assumptions. Somewhat related to this are the limitations on the City's ability to solve what are in effect regional, state, and national problems and issues. The City must work within the political framework within which it exists and with the limitations inherent in that framework.

SECTION 11. Summaries of Information. All summaries of information in the findings, which precede this section, are based on the substantial evidence in the record. The absence of any particular fact from any such summary is not an indication that a particular finding is not based in part on that fact.

SECTION 12. Electronic Signatures. This Resolution may be executed with electronic signatures in accordance with Government Code §16.5. Such electronic signatures will be treated in all respects as having the same effect as an original signature.

SECTION 13. This Resolution become effective immediately upon adoption and will remain effective until superseded by a subsequent resolution.

PASSED AND ADOPTED this ____ day of _____, 2022.

Henry Lo, Mayor

ATTEST:

Vincent D. Chang, City Clerk

APPROVED AS TO FORM:



Karl H. Berger, City Attorney



City Council Staff Report

DATE: November 16, 2022

AGENDA ITEM NO: Public Hearing - 4C

TO: The Honorable Mayor and City Council

FROM: Steve Sizemore, Interim Director of Community Development
Jessica Serrano, Planning Manager

SUBJECT: A public hearing to consider an application for a Wireless Telecommunications Facility Permit (DRB-22-49) to allow a new wireless telecommunications facility on an existing Southern California Edison Transmission Tower (DISH Wireless).

RECOMMENDATION:

It is recommended that the City Council consider:

1. Opening a public hearing and taking testimonial and documentary evidence;
2. After closing the public hearing and considering the evidence submitted during that public hearing, adopt the proposed Resolution granting a Wireless Telecommunications Facility Permit (DRB-22-49) with conditions of approval; and
3. Taking such additional, related action that may be desirable.

CEQA (California Environmental Quality Act):

The proposed action is exempt from additional environmental review under the California Environmental Quality Act (California Public Resources Code §§ 21000, *et seq.*, "CEQA") and CEQA Guidelines (14 California Code of Regulations ("CCR") §§ 15000, *et seq.*) because it consists of construction and location of a one new small facility or structure. Consequently, the project constitutes a Class 3 categorical exemption. A Notice of Exemption has been prepared accordingly.

EXECUTIVE SUMMARY:

DISH Wireless ("Applicant"), is requesting a Wireless Telecommunications Facility Permit to allow installation of a new wireless telecommunications facility on an existing Southern California Edison ("SCE") lattice transmission tower. The property is zoned R-1 (Single-Family Residential) and is designated P-F (Public Facilities) in the General Plan.

After reviewing the application, it appears the proposed project is consistent with the requirements and standards in the Monterey Park Municipal Code ("MPMC") and will not have significant impacts to the surrounding community. A wireless telecommunication facility is an allowed use subject to a Wireless Telecommunications Facility Permit and

the proposed project is consistent with the standards established in MPMC Chapter 21.34 for wireless telecommunication facilities.

OVERVIEW

In considering the application, the City Council is acting in a quasi-judicial, or adjudicative, capacity. When acting in that role, the City Council applies “law that already exists to determine specific rights based upon specific facts ascertained from evidence adduced at a hearing.”¹ A quasi-judicial action triggers the procedural due process rights of the United States and California Constitutions.² Under such circumstances, a party appearing before the legislative body is entitled to

1. Notice of the proposed action;
2. Reasons for the action;
3. A copy of the evidence on which the action is based; and
4. The right to respond “before a reasonably impartial, noninvolved reviewer.”³

The last requirement is one of fundamental fairness. It is a long-standing rule that quasi-judicial bodies can only make decisions based upon the evidence before them; they “cannot act on their own information.”⁴ A legislative body acting upon its own information, without a party’s input, does not conduct a fair hearing.⁵

There is nothing that prohibits an official from conducting an independent investigation.⁶ However, it is important that an official disclose his or her investigation and ex parte contact if information obtained through that contact could influence the official’s decision. Disclosure of this information provides a party with the opportunity to challenge or explain that evidence.

ADDITIONAL LEGAL CONSTRAINTS

The City’s ability to regulate wireless facilities is severely restricted by federal and state law. There are very limited circumstances where the City can exercise its land use authority as to wireless facilities.

¹ *Sierra Club v. Gilroy City Council* (1990) 222 Cal.App.3d 30, 38 [overruled on other grounds].

² U.S. Const. amend. V, XIV; Cal. Const. art. I, §§ 7, 15.

³ *Burrell v. City of Los Angeles* (1989) 209 Cal.App.3d 568, 581.

⁴ *English v. City of Long Beach* (1950) 35 Cal.2d 155.

⁵ *Safeway Stores, Inc. v. City of Burlingame* (1959) 170 Cal.App.2d 637, 647-48; *La Prade v. Dept. of Water & Power* (1945) 27 Cal.2d 47, 51-52.

⁶ *Todd v. City of Visalia* (1967) 254 Cal.App.2d 679, 691

➤ *1996 Telecommunications Act*

The 1996 Telecommunications Act (the “Act”) restricts the City’s ability to regulate the location, construction and modification of wireless communication facilities.⁷ As a result, when a city wishes to deny a wireless permit, it must make findings based upon “upon a written decision supported by substantial evidence.” This means “less than a preponderance, but more than a scintilla... [or] such relevant evidence as a reasonable mind might accept as adequate to support a finding.”⁸

A city must set forth its grounds for denial in writing, though “these reasons need not be elaborate or even sophisticated, but ... simply clear enough to enable judicial review.”⁹

➤ *Radio Frequency Emissions*

Federal law prevents the City from denying an application to build a wireless service facility based upon the environmental effects of radio frequency (“RF”) emissions from the proposed wireless site, provided that the facility complies with the Federal Communications Commission’s (“Commission” or “FCC”) regulations.¹⁰ This limitation was intended “to prevent a State or local government or its instrumentalities from basing the regulation of the placement, construction, or modification of ... facilities directly or indirectly on the environmental effects of radio frequency emissions if those facilities comply with the Commission’s regulations.”¹¹

Accordingly, there must be substantial evidence in the record of a reason other than health effects related to RF emissions to support a denial of a wireless facility application.¹²

➤ *Other considerations*

The City’s ability to deny or modify an application for reasons other than RF emissions is quite narrow. In general, the City may only require wireless facilities to comply with generally applicable building, structural, electrical, and safety codes and with other laws codifying objective standards reasonably related to health and safety.¹³ These standards likely also include regulations requiring wireless facilities to be camouflaged or concealed as part of its objective codes regulating buildings and standards.¹⁴

⁷ 47 U.S.C. § 332(c)(7); *T-Mobile South, LLC v. City of Roswell* (2015) 135 S.Ct. 808, 814; citing *Rancho Palos Verdes v. Abrams* (2015) 544 U.S. 113, 115.

⁸ *AT & T Wireless Services of California, LLC v. City of Carlsbad* (S.D. Cal. 2003) 308 F. Supp. 2d 1148, 1159.

⁹ *City of Roswell, infra.*, 135 S. Ct. at 815.

¹⁰ 47 U.S.C. § 332(c)(7)(B)(iv).

¹¹ *City of Carlsbad, infra.*, 308 F. Supp. 2d at 1158-1159.

¹² *AT & T Wireless Services of California, LLC v. City of Carlsbad* (S.D. Cal. 2003) 308 F. Supp. 2d 1148, 1159-1160.

¹³ FCC Report and Order, ¶¶ 201-202.

¹⁴ See 47 CFR § 1.1307 (the FCC does not require environmental review where “[t]he new antenna

Congress's intent in enact these laws "was to promote the deployment of wireless broadband services."¹⁵ Such laws were adopted in part in response to complaints by the wireless industry that states and localities were refusing to approve even minor modifications to existing towers.¹⁶ In essence, federal law mandates that the City approve wireless facilities absent some significant failure to comply with applicable federal regulation or local building standards.

BACKGROUND:

The project location is on an existing SCE property used for transmission towers and lines, located on the north side of Arroyo Drive at Ackley Street (APN 5276-018-804). The SCE property is approximately 9.43 acres in size and starts from the City's eastern boundary and just passes Arroyo Drive as shown in the site map below. Surrounding land uses include residential uses that are northwesterly, and the continuation of the SCE transmission tower and lines to the south, east, and west of the project site.



Project Site

The proposed facility includes three directional panel antennas and accessory radio equipment on the existing 121 foot lattice power-line tower located in a utility easement crossing Arroyo Drive in Monterey Park; one of several similarly situated on the property, is north of Arroyo Drive and East of Ackley Street. This proposal constitutes a Class 4 antenna as it is proposed to be mounted on an existing utility lattice tower per MPMC §

complies with all zoning conditions ... applicable to existing antennas in the same vicinity that directly mitigate or prevent effects, such as camouflage or concealment requirements").

¹⁵ FCC Report and Order in the Matter of Acceleration of Broadband Deployment by Improving Wireless Facilities Siting Policies (adopted October 17, 2014) ("FCC Report and Order"). The FCC Report and Order took effect on April 8, 2015.

¹⁶ 112 P.L. 96, § 6409.

21.04.074. Because the proposed wireless antenna is located in a residential zone, MPMC § 21.34.020(B)(1) requires that the City Council approve the permit.

The applicant asserts that the proposed project would provide higher quality wireless telecommunications services to the service area. Among other things, the Applicant's proposal seeks to increase capacity for data usage to eliminate gaps in service for the Applicant's customers.

The Applicant submitted draft findings for Class 4 antenna installations in residential zones as required by MPMC § 21.34.020(F). Although the current proposal is in the R-1 zone, the property itself does not contain any residential land uses and is therefore a more compatible location for a new antenna installation than other nearby properties with residential uses. The property is one of several SCE-owned parcels that form a utility corridor running north from its nearby Mesa Substation. The adjacent SCE owned parcels also support existing antenna installations on similar lattice towers, which makes the Applicant's proposed antenna installation consistent and compatible with the existing conditions.

The antennas are passive, generating little to no noise. The Applicant submitted a noise study to show that the proposed wireless facility complies with MPMC Chapter 4.50 which regulates noise. The maximum noise level of the ground mounted equipment cabinet is 64.3 decibels (dBA), measured at a reference distance of 5 feet. The maximum calculated noise level at the nearest property line from the Applicant's operation is 45.2 dBA, well below the City's most restrictive, residential nighttime limit of 50 dBA (see, MPMC § 4.50.080(A)). Overall, operation of the wireless telecommunication facility will comply with the City's requirement for limiting acoustic noise emission levels.

A notice of public hearing was published in the *Monterey Park Press* on November 3, 2022 and posted at the City's three posting places at City Hall, Monterey Park Bruggermeyer Library, and Langley Center on November 3, 2022. The hearing notice was mailed to 153 property owners within 300 feet of the project boundaries on November 3, 2022.

FISCAL IMPACT:

There are no identifiable fiscal impacts associated with granting a wireless permit. The Applicant paid all fees associated with processing its application.

Respectfully submitted by:



Steve Sizemore
Interim Director of Community
Development

Prepared by:



Jessica Serrano,
Planning Manager

Approved by:

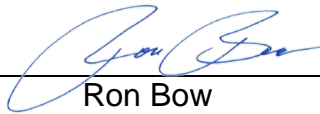

Ron Bow
City Manager

Reviewed by:

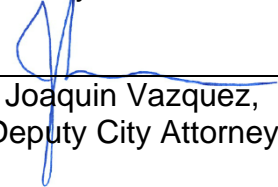

Joaquin Vazquez,
Deputy City Attorney

Attachments:

- Attachment 1: Draft Resolution
- Attachment 2 Site, floor, and elevation plans
- Attachment 3: Photo Simulations

Staff Report
November 16, 2022

Attachment 1

Draft Resolution

RESOLUTION NO. ___

A RESOLUTION APPROVING WIRELESS TELECOMMUNICATIONS FACILITY PERMIT (DRB-22-49) TO ALLOW A NEW WIRELESS TELECOMMUNICATIONS FACILITY AT ASSESSOR PARCEL NUMBER 5276-018-804.

The Council of the City of Monterey Park does resolve as follows:

SECTION 1: The City Council finds and declares that:

- A. On September 8, 2022, Rob Searcy, representing DISH Wireless (the "Applicant"), submitted an application requesting approval of Wireless Telecommunications Facility Permit (DRB-22-49) to install a new wireless telecommunications facility on an existing Southern California Edison ("SCE") transmission tower (the "Project") located on property on the north side of Arroyo Drive approximately 150 feet southeast of its intersection with Ackley Street (APN 5276-018-804) (the "Property"). This application is made pursuant to Monterey Park Municipal Code ("MPMC") Chapter 21.34 and §§ 21.07.050(H) and 21.32.020;
- B. The proposed Project was reviewed by the Interim Community Development Director, and designees, for, in part, consistency with the General Plan and conformity with the MPMC;
- C. In addition, the City reviewed the Project's environmental impacts under the California Environmental Quality Act (Public Resources Code §§ 21000, et seq., "CEQA") and the regulations promulgated thereunder (14 California Code of Regulations §§ 15000, et seq., the "CEQA Guidelines");
- D. The Interim Community Development Director, and designees, completed review of the Project and scheduled a public hearing regarding the Project before the City Council for November 16, 2022. Notice of the public hearing was posted and mailed as required by the MPMC;
- E. On November 16, 2022, the City Council held a public hearing to receive public testimony and other evidence regarding the proposed Project, including, without limitation, information provided to the City Council by City staff and public testimony, and representatives of the Applicant; and
- F. This Resolution and its findings are made based upon the testimony and evidence presented to the City Council at its

November 16, 2022 public hearing including, without limitation, the staff report submitted by the City Planner.

SECTION 2: Planning Agency. Pursuant to MPMC § 2.56.020(A), the City Council will act as the Monterey Park Planning Agency for purposes of this Resolution.

SECTION 3: Factual Findings and Conclusions. The City Council finds that the following facts exist and makes the following conclusions:

- A. The Applicant seeks to install a new wireless telecommunication facility on an existing SCE lattice transmission tower. The new facility will include three directional antennas and accessory radio equipment on the 121-foot lattice power-line tower located in a utility easement crossing Arroyo Drive. The tower, one of several similarly situated, is north of Arroyo Drive and East of Ackley Street. A ground mounted, 185 square foot ancillary support equipment enclosure is proposed below the tower;
- B. The Property is zoned R-1 (Single-Family Residential) and designated "Public Facilities" in the General Plan. The proposed wireless telecommunications facility complies with the the development regulations and the Wireless Telecommunications Facilities regulations in the MPMC;
- C. The Project will not be detrimental to the public health, safety, and welfare or adversely affect property values or the present or future development of surrounding areas with the incorporation of the conditions of approval. The Project will be low profile to have minimal visual impact. Accordingly, it will not be visually obtrusive;
- D. The Project was designed to achieve compatibility with the community to the maximum extent feasible. While the Property is zoned R-1, the Property itself does not contain any residential land uses. It is therefore a more compatible location for a new antenna installation than other nearby properties with residential uses. The Property is one of several SCE-owned parcels that form a utility corridor running north from its nearby Mesa Substation. Installing the Project on the Property is compatible with the existing utility-oriented land use of the Property and directly adjacent parcels to the north and south;
- E. Alternative locations on the site will not increase community compatibility and are not reasonably feasible. There are several other lattice towers and power poles on the Property;

- F. The Project is necessary to close a significant gap in coverage. The Applicant currently does not have any other locations in the Monterey Park area. Consequently, there is no existing coverage footprint and the entire area is considered a significant gap in coverage. There will be increased capacity for data usage, to eliminate the gaps in service for the Applicant's customers;
- G. While the Applicant does not own the lattice tower or the parcel that is subject of this application it will allow other carriers to co-locate on its Project where technically and economically feasible and where co-location would not harm community compatibility;
- H. Noise generated by the facility will not exceed the limitations in MPMC Chapter 4.50. The Project must comply with the residential sound level limits in MPMC § 4.50.080(A); and
- I. The Project must comply with all local, State, and Federal laws, including, without limitation, the Federal Communication Commission's (FCC's) standards for human exposure to radio energy.

SECTION 4: *Environmental Review.* This Resolution is exempt from additional environmental review under the California Environmental Quality Act (California Public Resources Code §§ 21000, *et seq.*, "CEQA") and CEQA Guidelines (14 California Code of Regulations ("CCR") §§ 15000, *et seq.*) because it consists of construction and location of a one new small facility or structure. Consequently, the project constitutes a Class 3 categorical exemption.

SECTION 5: *Action.* The City Council takes the following actions:

- A. Subject to the Conditions of Approval attached as Exhibit A, and incorporated by reference, the City Council grants the Wireless Telecommunications Facility Permit (DRB-22-49).
- B. The City Council directs staff to file the Notice of Exemption within five calendar days.

SECTION 6: *Electronic Signatures.* This Resolution may be executed with electronic signatures in accordance with Government Code §16.5. Such electronic signatures will be treated in all respects as having the same effect as an original signature.

SECTION 7: *Construction.* This Resolution must be broadly construed in order to achieve the purposes stated in this Resolution. It is the City Council's intent that the

provisions of this Resolution be interpreted or implemented by the City and others in a manner that facilitates the purposes set forth in this Resolution.

SECTION 8: Recordation. The Mayor, or presiding officer, is authorized to sign this Resolution signifying its adoption by the City Council of the City of Monterey Park and the City Clerk, or her duly appointed deputy, may attest thereto.

SECTION 9: Effective Date. This Resolution will become effective immediately upon adoption and will remain effective unless repealed or superseded.

PASSED AND ADOPTED this ____ day of November 2022.

Henry Lo, Mayor

ATTEST:

Vincent D. Chang, City Clerk

APPROVED AS TO FORM
KARL H. BERGER, City Attorney

By: 

Joaquin Vazquez, Deputy City Attorney

CITY COUNCIL RESOLUTION NO.

Exhibit A CONDITIONS OF APPROVAL

In addition to all applicable provisions of the Monterey Park Municipal Code (“MPMC”), DISH Wireless agrees that it will comply with the following conditions of approval for Wireless Telecommunications Facility Permit (DRB-22-49) (“Project Conditions”).

1. DISH Wireless (the “Permittee”) agrees to indemnify and hold the City harmless from and against any claim, action, damages, costs (including, without limitation attorney’s fees), injuries, or liability arising from the City’s Approval of DRB-22-49 except for such loss or damage arising from the City’s sole negligence or willful misconduct. Should the City be named in any suit, or should any claim be brought against it by suit or otherwise, whether the same be groundless or not, arising out of the City approval of DRB-22-49, the Permittee agrees to defend the City (at the City’s request and with counsel satisfactory to the City) and will indemnify the City for any judgement rendered against it or any sums paid out in settlement or otherwise. For purposes of this section “City” includes the City of Monterey Park’s elected officials, appointed officials, officers, and employees.
2. This approval is for the project as shown on the plans reviewed and approved by the City Council and on file. Before the City issues a building permit, the Permittee must submit plans, showing that the project substantially complies with the plans and conditions of approval on file with the Planning and Building and Safety Divisions. Any subsequent modification must be referred to the Director of Community Development for a determination regarding the need for City Council review and approval of the proposed modification.
3. Approval of this Wireless Telecommunications Permit becomes effective immediately upon adoption.
4. The wireless telecommunications facility is deemed abandoned and must be promptly removed if it ceases to provide wireless telecommunications services for 90 or more consecutive days. Such removal must be accomplished in accordance with applicable law including, without limitation, the MPMC.
5. If the facility is not removed, the Director may cause the facility to be removed at the owner’s expense in accordance with MPMC Chapter 4.4. If there is an additional but separate permittee located on the facility location, then this Condition does not become effective until all users cease using the facility.
6. Upon assignment or transfer of an already approved wireless telecommunications facility or any rights under that permit, the owner and/or current operator of the facility must provide written notification of such action to the Director 30 days.

7. No signs, striping, graphics or advertising are permitted on a wireless telecommunications facility, other than those specifically named in the conditions herein.
8. Graffiti must be removed from any facility or equipment as soon as practicable, and in no instance more than 24 hours from the time of notification by the City.
9. A copy of these Conditions of Approval must be printed on the title sheet of the final building construction plans before the City issues building permits.
10. Permittee must apply and obtain an address for the location with the Public Works Department.
11. These Conditions of Approval must be executed by the Permittee before the City issues any permits in accordance with applicable law.
12. Barbed wire and razor wire is prohibited on the equipment enclosure or antenna installation.
13. The equipment/facility cannot interfere with any Police or Fire Department radio or digital communications or exchange.
14. If the City Manager, or designee, determines that the equipment/facility is interfering with any Police or Fire Department radio communications, the applicant must shut down the facility immediately upon being notified of such problems. The facility cannot become operational until the applicant has proven to the Police Department that the problem has been fixed and will not interfere with any Police or Fire Department radio communications or digital equipment.
15. Each owner or operator of a wireless telecommunications facility must provide the Community Development Department with the name and 24 hour local or toll-free contact phone number of both the permittee and the agent responsible for the maintenance of the wireless telecommunications facility. Contact information must be kept current.

By signing this document, this certifies that duly authorized representatives of both SureSite and DISH Wireless have read, understood, and agree to the Project Conditions listed in this document.

Name, Title
signing on behalf of SureSite, Permittee

Name, Title
signing on behalf of DISH Wireless, Permittee

Attachment 2

Site, floor, and elevation plans



PROJECT NO: LALAX04290B
DRAWN BY: MG
CHECKED BY: NC/BC/DW

REV	DATE	DESCRIPTION	BY
0	11/11/2021	FINAL SURVEY	NC
B	10/08/2021	PLS PRELIM SURVEY	NC
A	10/05/2021	PRELIMINARY SURVEY	MG



IT IS A VIOLATION OF LAW FOR ANY PERSON, UNLESS THEY ARE ACTING UNDER THE DIRECTION OF A LICENSED PROFESSIONAL ENGINEER, TO ALTER THIS DOCUMENT.

LALAX04290B
A.P.N. 5276-018-804
N/O ARROYO DR. AND E/O ACKLEY ST
MONTEREY PARK, CA, 91755
NEW BUILD

SHEET TITLE
SITE SURVEY

SHEET NUMBER
C-1

- LEGEND**
- U.G. UTILITY VAULT
 - ⊕ MANHOLE
 - UTILITY POLE
 - SPOT ELEVATION
 - ⊙ WATER VALVE
 - ⊙ FOUND MONUMENT
 - LP LIGHT POLE
 - EOP EDGE OF PAVEMENT
 - R.O.W. RIGHT OF WAY
 - R/W RIGHT OF WAY
 - ⊕ GEODETIC MARKER
 - x — CHAIN LINK FENCE
 - o — WOOD FENCE
 - o/h — OVERHEAD LINE
 - o — METAL FENCE
 - | — GRADE BREAK
 - PS PARKING STRIPE
 - SW SIDEWALK
 - VL U.G. UTILITY VAULT
 - — RIGHT OF WAY LINE
 - — CENTER LINE
 - — EASEMENT LINE
 - BLDG BLDG
 - CONC CONCRETE
 - PED PEDESTAL
 - NG NATURAL GRADE
 - UP UTILITY POLE
 - LP LIGHT POLE
 - WLP WOOD LIGHT POLE
 - SCO SEWER CLEAN-OUT
 - AC ASPHALTIC CONCRETE
 - AP ASPHALT PAVING
 - SVC SERVICE
 - OH OVERHEAD
 - PUE PUBLIC UTILITY EASEMENT
 - LUM LUMINAIRE
 - BCM BRASS CAP MONUMENT
 - MON MONUMENT
 - OHE OVERHEAD ELECTRICAL

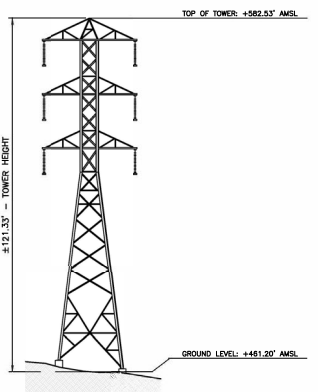

② TOWER ELEVATION
1 inch = 20 ft.

CENTER OF LEASE AREA
POSITION OF GEODETIC COORDINATES
LATITUDE: 34° 02' 48.29" NORTH (NAD83)
LONGITUDE: 118° 06' 11.95" WEST (NAD83)
GRADE ELEVATION: 461.20' AMSL (NAVDBS)

FD MON. #1:
FOUND LEAD AND TAG
IN CONCRETE CURB
ELEV: +454.01' AMSL

FD MON. #2:
FOUND LEAD AND TAG
IN CONCRETE CURB
ELEV: +453.76' AMSL

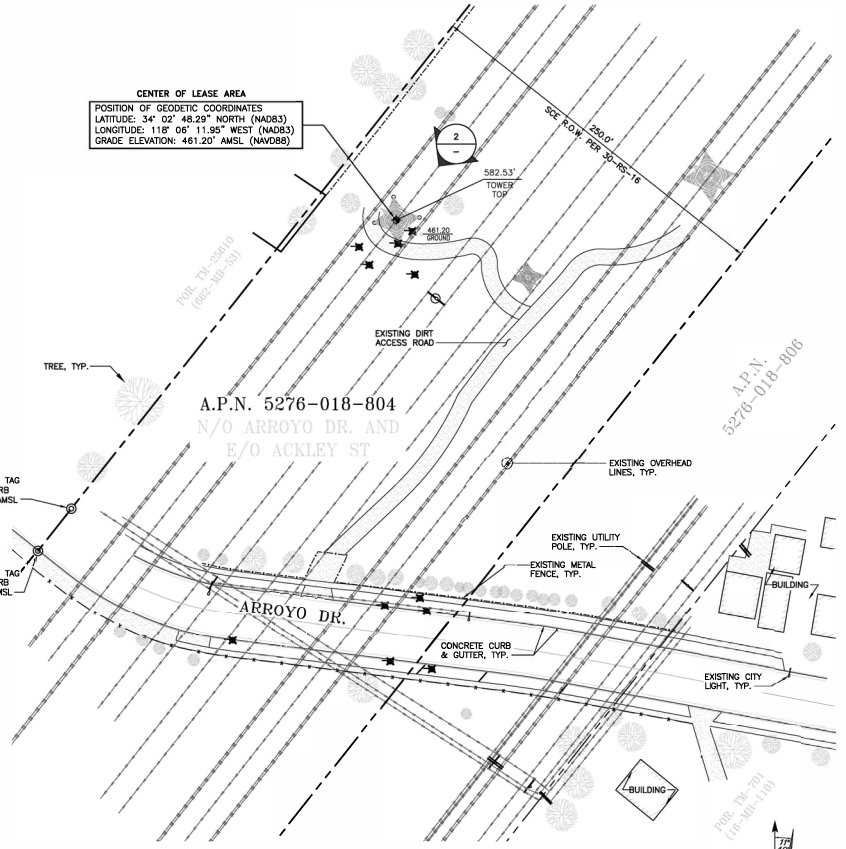

① SITE LOCATION
1 inch = 40 ft.

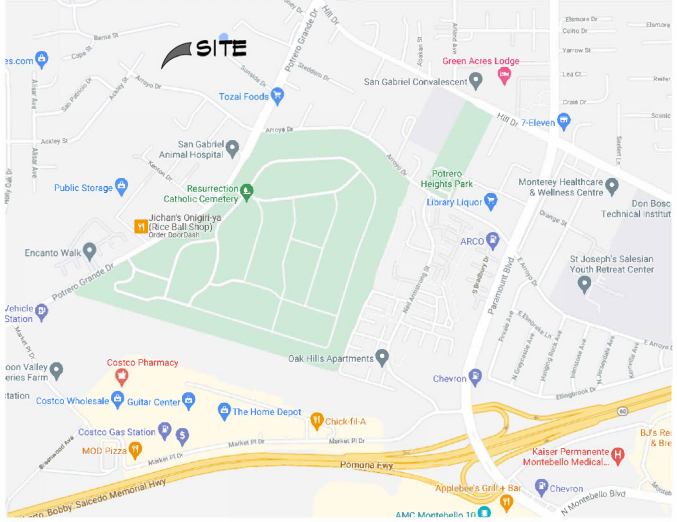

NOTES:

- THIS IS NOT A BOUNDARY SURVEY. THIS IS A SPECIALIZED TOPOGRAPHIC MAP. THE PROPERTY LINES AND EASEMENTS SHOWN HEREON ARE FROM RECORD INFORMATION AS NOTED HEREON. THIS SURVEY IS INTENDED FOR EXHIBIT PURPOSES AND NOT FOR RECORDATION AS AN OFFICIAL RECORD OF SURVEY DRAWING. ALL STATES ENGINEERING & SURVEYING/ZALZAJ & ASSOCIATES, INC. TRANSLATES THE TOPOGRAPHIC SURVEY TO RECORD INFORMATION USING MONUMENTS/ANGULAR MARKS SHOWN HEREON. NO TITLE RESEARCH WAS PERFORMED BY ALL STATES ENGINEERING & SURVEYING/ZALZAJ & ASSOCIATES, INC.
- ANY CHANGES MADE TO THE INFORMATION ON THIS PLAN, WITHOUT THE WRITTEN CONSENT OF ALL STATES ENGINEERING & SURVEYING / ZALZAJ & ASSOCIATES, INC. RELIEVES ALL STATES ENGINEERING & SURVEYING / ZALZAJ & ASSOCIATES, INC. OF ANY AND ALL LIABILITY.
- THESE DRAWINGS & SPECIFICATIONS ARE THE PROPERTY & COPYRIGHT OF ALL STATES ENGINEERING & SURVEYING / ZALZAJ & ASSOCIATES, INC. & SHALL NOT BE USED ON ANY OTHER WORK EXCEPT BY AGREEMENT WITH THE SURVEYOR, AND BY WRITTEN PERMISSION FROM ALL STATES ENGINEERING & SURVEYING/ZALZAJ & ASSOCIATES, INC.
- WRITTEN DIMENSIONS SHALL TAKE PREFERENCE OVER SCALED & SHALL BE VERIFIED ON THE JOB SITE. ANY DISCREPANCY SHALL BE NOTICED TO THE SURVEYOR PRIOR TO COMMENCEMENT OF ANY WORK.
- THIS SITE IS PROPOSED TO BE DEVELOPED ON A TOWER LOCATED WITHIN PRIVATE ROW/PROPERTY IN THE CITY OF MONTEREY PARK, COUNTY OF LOS ANGELES, STATE OF CALIFORNIA.
- NO TITLE INFORMATION HAS BEEN PROVIDED, TO DATE, FOR INCLUSION INTO THIS SURVEY DRAWING.

UTILITY NOTE:

SURVEYOR DOES NOT GUARANTEE THAT ALL UTILITIES ARE SHOWN OR THEIR LOCATIONS ARE DEFINITE. IT IS THE RESPONSIBILITY OF THE CONTRACTOR AND DEVELOPER TO CONTACT BLUE STAKE AND ANY OTHER INVOLVED AGENCIES PRIOR TO CONSTRUCTION. REMOVAL, RELOCATION AND/OR REPLACEMENT IS THE RESPONSIBILITY OF THE CONTRACTOR.

SURVEY DATE
09/25/2021

BENCHMARK
RTCM-REF 3239
NORTHING: 1881397.22
EASTING: 6309744.89
+929.21' (A.M.S.L.)

BASIS OF BEARING
BEARINGS SHOWN HEREON ARE BASED UPON U.S. STATE PLANE NAD83 COORDINATE SYSTEM CALIFORNIA STATE PLANE COORDINATE ZONE 5, DETERMINED BY GPS OBSERVATIONS.

REFERENCE MAPS
• 30 - RS - 16

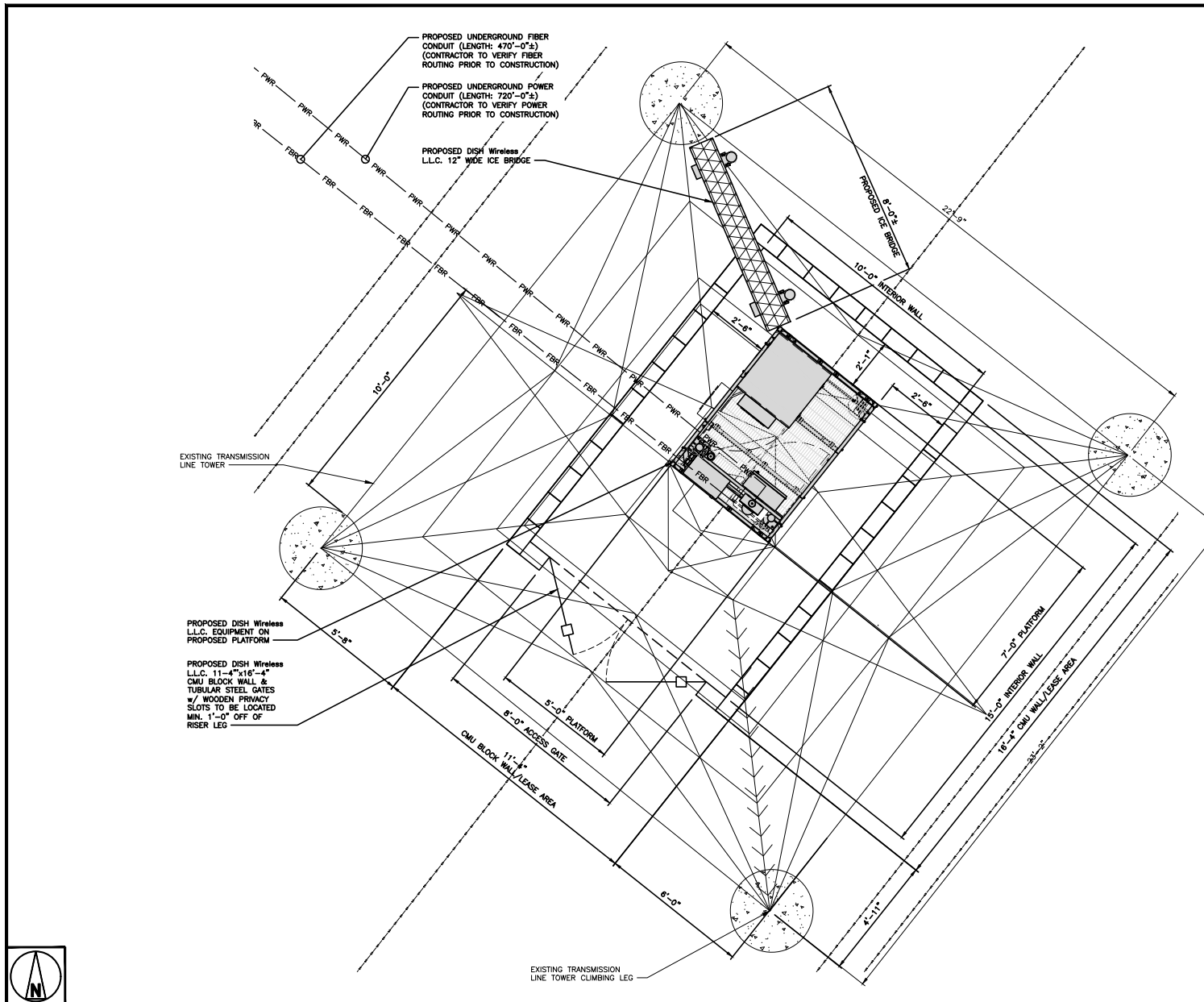

- NOTES**
1. CONTRACTOR SHALL FIELD VERIFY ALL DIMENSIONS.
 2. CONTRACTOR SHALL MAINTAIN A 10'-0" MINIMUM SEPARATION BETWEEN THE PROPOSED GPS UNIT, TRANSMITTING ANTENNAS AND EXISTING GPS UNITS.
 3. ANTENNAS AND MOUNTS OMITTED FOR CLARITY.

dish
wireless.

5701 SOUTH SANTA FE DRIVE
LITTLETON, CO 80120

SURESITE

3659 GREEN ROAD, SUITE 214
CLEVELAND, OH 44122

IT IS A VIOLATION OF LAW FOR ANY PERSON, UNLESS THEY ARE ACTING UNDER THE DIRECTION OF A LICENSED PROFESSIONAL ENGINEER, TO ALTER THIS DOCUMENT.

DRAWN BY:	CHECKED BY:	APPROVED BY:
BWG	AMR	AB
RFDS REV #:		2

ZONING DOCUMENTS

SUBMITTALS

REV	DATE	DESCRIPTION
0	11/15/2021	FINAL ZONING DRAWINGS
1	12/03/2021	CLIENT COMMENTS
2	12/13/2021	CLIENT COMMENTS
3	03/09/2022	SCE COMMENTS
4	05/09/2022	SCE COMMENTS
5	05/31/2022	SCE COMMENTS
6	07/06/2022	SCE COMMENTS

A&E PROJECT NUMBER
LALAX04290B

DISH Wireless L.L.C.
PROJECT INFORMATION
LALAX04290B
N/O ARROYO DR & E/O
ACKLEY ST
MONTEREY PARK, CA 91755

SHEET TITLE
ENLARGED SITE PLAN

SHEET NUMBER
A-2



ENLARGED SITE PLAN

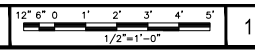

DISH Wireless L.L.C. TEMPLATE VERSION 45 - 10/29/2021

NOTE: ANTENNA FRAMES/SHROUDS TO BE FABRICATED & INSTALLED BY SCE

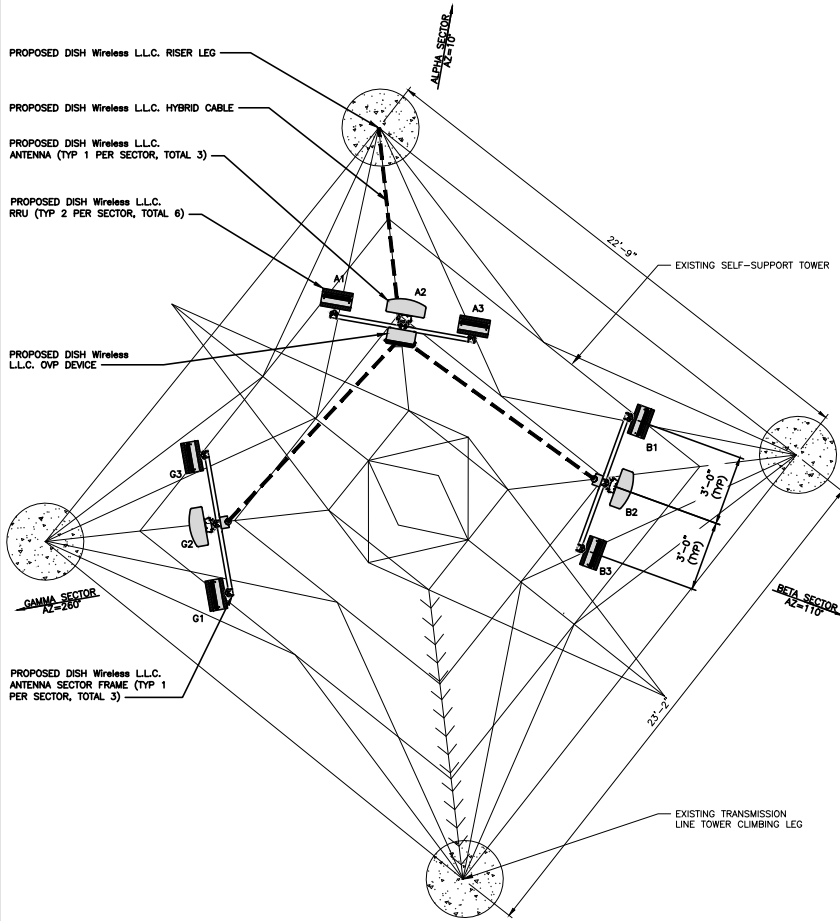

SECTOR			EQUIPMENT						CABLES				
NAME	BRACKET AZ. (DEG)	BRACKET CENTER(FT)	POSITION	NUMBER	MAKE/MODEL	HEIGHT (IN)	WIDTH (IN)	DEPTH (IN)	WEIGHT (LBS)	TYPE	LENGTH (FT)	TYPE	LENGTH (FT)
SECTOR "A"	10°	42'-0"	A1	1	FUJITSU - TA08025 B605	14.96"	15.75"	9.06"	74.95 LBS	HIGH-CAPACITY HYBRID CABLE (CUI12PSM9PB)	50 FT	(1) HIGH-CAPACITY HYBRID CABLE (CUI12PSM9PB)	50 FT
			A2	1	JMA - MX08FR0665-21	72.8"	20.0"	8.0"	82.5 LBS				
			PIVOT POST	1	RAYCAP -RDIC9181-PF-48	14.0"	16.0"	8.0"	21.82 LBS				
SECTOR "B"	110°	42'-0"	A3	1	FUJITSU - TA08025 B604	14.96"	15.75"	7.87"	63.93 LBS	HIGH-CAPACITY HYBRID CABLE (CUI12PSM9PB)	50 FT	(1) HIGH-CAPACITY HYBRID CABLE (CUI12PSM9PB)	50 FT
			B1	1	FUJITSU - TA08025 B605	14.96"	15.75"	9.06"	74.95 LBS				
			B2	1	JMA - MX08FR0665-21	72.8"	20.0"	8.0"	82.5 LBS				
SECTOR "G"	260°	42'-0"	B3	1	FUJITSU - TA08025 B604	14.96"	15.75"	7.87"	63.93 LBS	HIGH-CAPACITY HYBRID CABLE (CUI12PSM9PB)	50 FT	(1) HIGH-CAPACITY HYBRID CABLE (CUI12PSM9PB)	50 FT
			G1	1	FUJITSU - TA08025 B605	14.96"	15.75"	9.06"	74.95 LBS				
			G2	1	JMA - MX08FR0665-21	72.8"	20.0"	8.0"	82.5 LBS				
SECTOR "G"	260°	42'-0"	G3	1	FUJITSU - TA08025 B604	14.96"	15.75"	7.87"	63.93 LBS	HIGH-CAPACITY HYBRID CABLE (CUI12PSM9PB)	50 FT	(1) HIGH-CAPACITY HYBRID CABLE (CUI12PSM9PB)	50 FT



5701 SOUTH SANTA FE DRIVE
LITTLETON, CO 80120



3659 GREEN ROAD, SUITE 214
CLEVELAND, OH 44122

IT IS A VIOLATION OF LAW FOR ANY PERSON, UNLESS THEY ARE ACTING UNDER THE DIRECTION OF A LICENSED PROFESSIONAL ENGINEER, TO ALTER THIS DOCUMENT.

DRAWN BY: BWC CHECKED BY: AMR APPROVED BY: AB

RFDS REV #: 2

ZONING DOCUMENTS

REV	DATE	DESCRIPTION
0	11/15/2021	FINAL ZONING DRAWINGS
1	12/03/2021	CLIENT COMMENTS
2	12/13/2021	CLIENT COMMENTS
3	03/09/2022	SCE COMMENTS
4	05/09/2022	SCE COMMENTS
5	05/31/2022	SCE COMMENTS
6	07/06/2022	SCE COMMENTS

A&E PROJECT NUMBER
LALAX04290B

DISH Wireless L.L.C.
PROJECT INFORMATION
LALAX04290B
N/O ARROYO DR & E/O
ACKLEY ST
MONTEREY PARK, CA 91755

SHEET TITLE
ANTENNA
LAYOUT AND SCHEDULE

SHEET NUMBER

A-3

ANTENNA LAYOUT

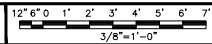

1

ANTENNA SCHEDULE

NO SCALE

2

NOTES

1. CONTRACTOR SHALL FIELD VERIFY ALL DIMENSIONS.
2. ANTENNA SPECIFICATIONS REFER TO ANTENNA SCHEDULE AND TO FINAL CONSTRUCTION RFDS FOR ALL RF DETAILS

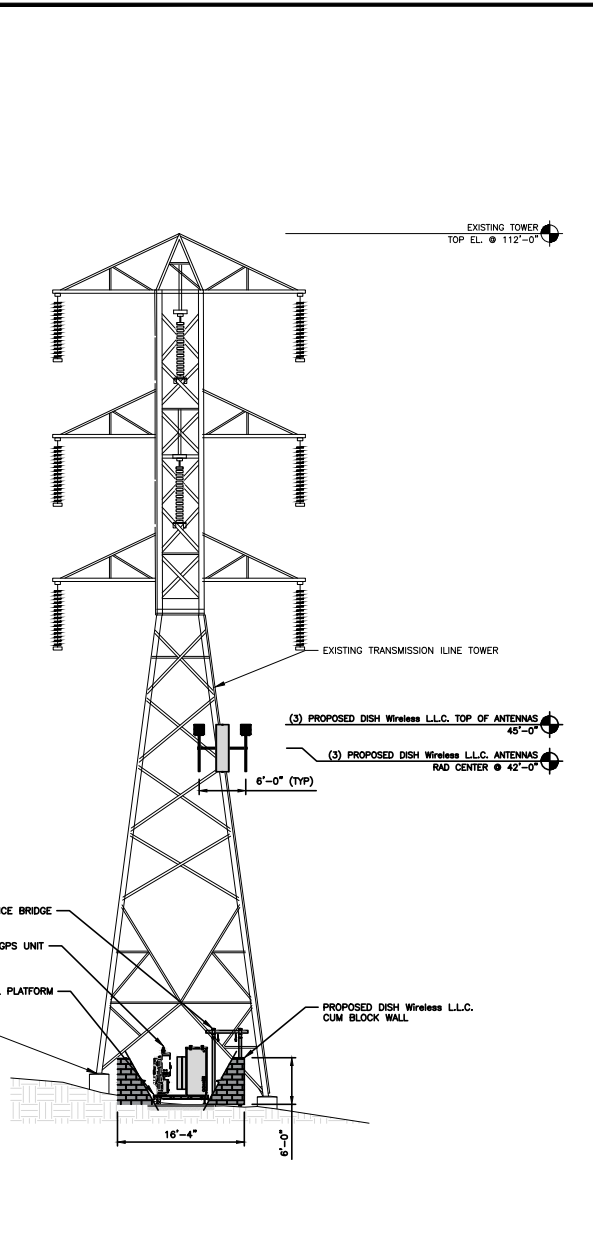

PROPOSED EAST ELEVATION

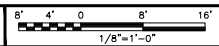

1

NOTES

1. CONTRACTOR SHALL FIELD VERIFY ALL DIMENSIONS.
2. ANTENNA DISH SPECIFICATIONS REFER TO ANTENNA SCHEDULE AND TO FINAL CONSTRUCTION RFDS FOR ALL RF DETAILS

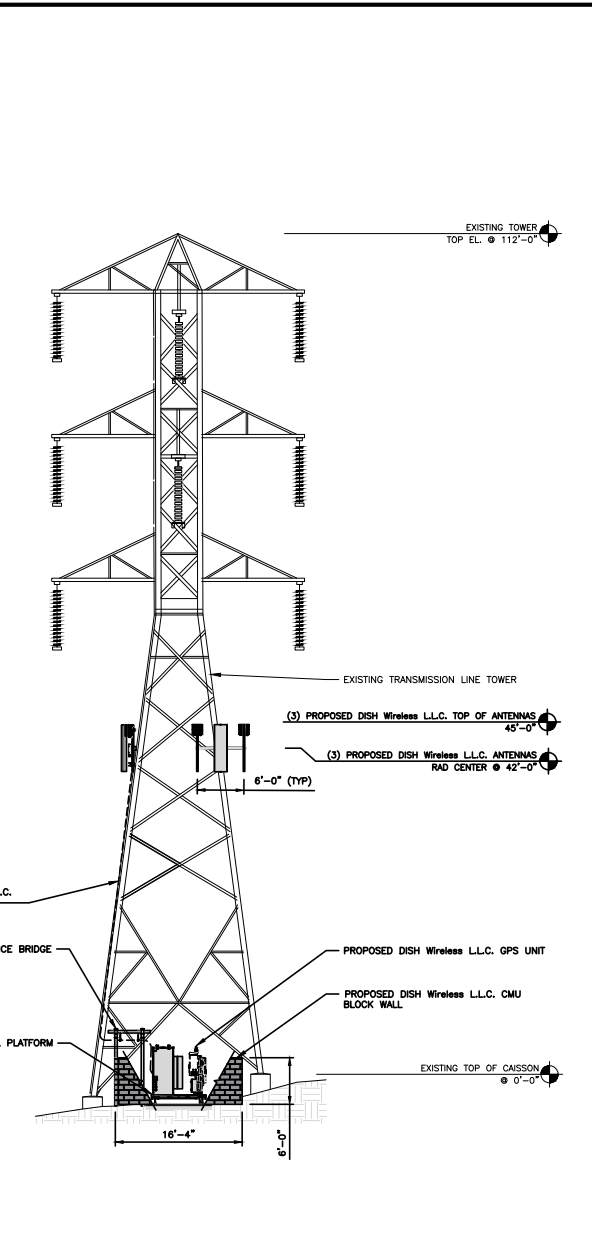

PROPOSED WEST ELEVATION

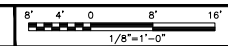

2



5701 SOUTH SANTA FE DRIVE
LITTLETON, CO 80120



3659 GREEN ROAD, SUITE 214
CLEVELAND, OH 44122

IT IS A VIOLATION OF LAW FOR ANY PERSON, UNLESS THEY ARE ACTING UNDER THE DIRECTION OF A LICENSED PROFESSIONAL ENGINEER, TO ALTER THIS DOCUMENT.

DRAWN BY: BWC
CHECKED BY: AMR
APPROVED BY: AB

RFDS REV #: 2

ZONING DOCUMENTS

SUBMITTALS		
REV	DATE	DESCRIPTION
0	11/15/2021	FINAL ZONING DRAWINGS
1	12/03/2021	CLIENT COMMENTS
2	12/13/2021	CLIENT COMMENTS
3	03/09/2022	SCE COMMENTS
4	05/09/2022	SCE COMMENTS
5	05/31/2022	SCE COMMENTS
6	07/06/2022	SCE COMMENTS

A&E PROJECT NUMBER
LALAX04290B

DISH Wireless L.L.C. PROJECT INFORMATION
LALAX04290B
N/O ARROYO DR & E/O
ACKLEY ST
MONTEREY PARK, CA 91755

SHEET TITLE
ELEVATIONS

SHEET NUMBER

A-4

NOTES

1. CONTRACTOR SHALL FIELD VERIFY ALL DIMENSIONS.
2. ANTENNA DISH SPECIFICATIONS REFER TO ANTENNA SCHEDULE AND TO FINAL CONSTRUCTION RFDS FOR ALL RF DETAILS

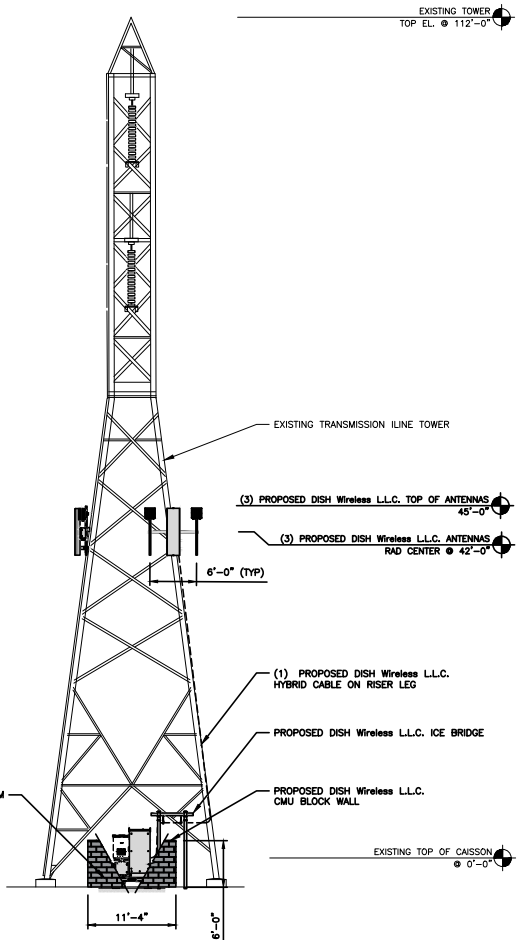

PROPOSED NORTH ELEVATION

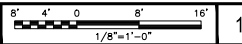

NOTES

1. CONTRACTOR SHALL FIELD VERIFY ALL DIMENSIONS.
2. ANTENNA DISH SPECIFICATIONS REFER TO ANTENNA SCHEDULE AND TO FINAL CONSTRUCTION RFDS FOR ALL RF DETAILS

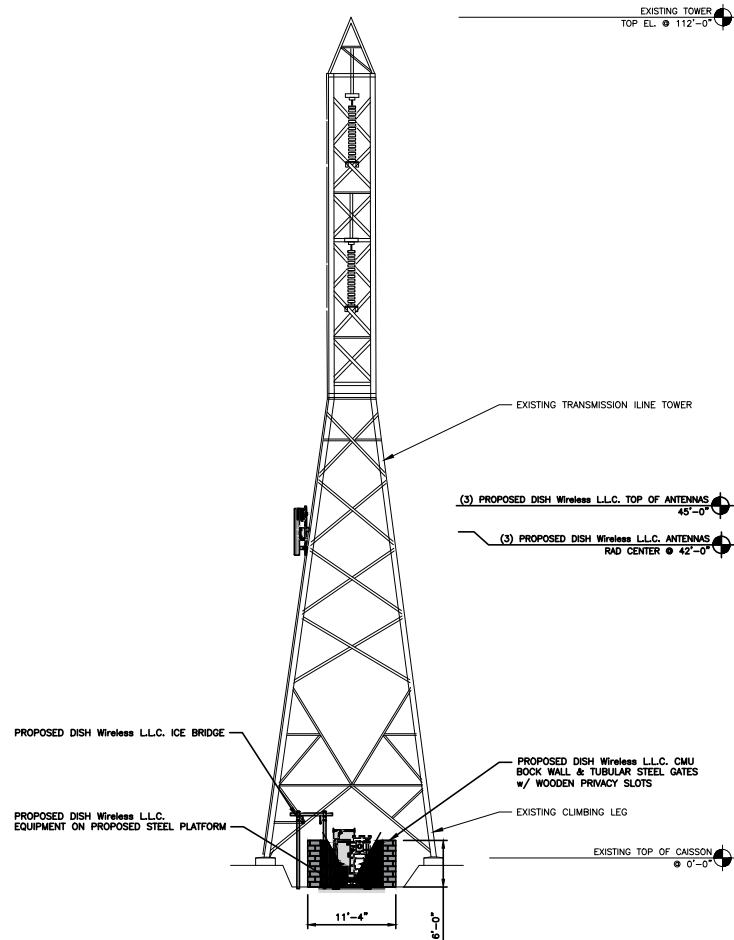

PROPOSED SOUTH ELEVATION

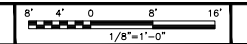

5701 SOUTH SANTA FE DRIVE
LITTLETON, CO 80120



3659 GREEN ROAD, SUITE 214
CLEVELAND, OH 44122

IT IS A VIOLATION OF LAW FOR ANY PERSON, UNLESS THEY ARE ACTING UNDER THE DIRECTION OF A LICENSED PROFESSIONAL ENGINEER, TO ALTER THIS DOCUMENT.

DRAWN BY:	CHECKED BY:	APPROVED BY:
BWG	AMR	AB

RFDS REV #: 2

ZONING DOCUMENTS

REV	DATE	SUBMITTALS
0	11/15/2021	FINAL ZONING DRAWINGS
1	12/03/2021	CLIENT COMMENTS
2	12/13/2021	CLIENT COMMENTS
3	03/09/2022	SCE COMMENTS
4	05/09/2022	SCE COMMENTS
5	05/31/2022	SCE COMMENTS
6	07/06/2022	SCE COMMENTS

A&E PROJECT NUMBER
LALAX04290B

DISH Wireless L.L.C.
PROJECT INFORMATION
LALAX04290B
N/O ARROYO DR & E/O
ACKLEY ST
MONTEREY PARK, CA 91755

SHEET TITLE
ELEVATIONS

SHEET NUMBER

A-5

ANTENNA MOUNTING BRACKET ASSEMBLY

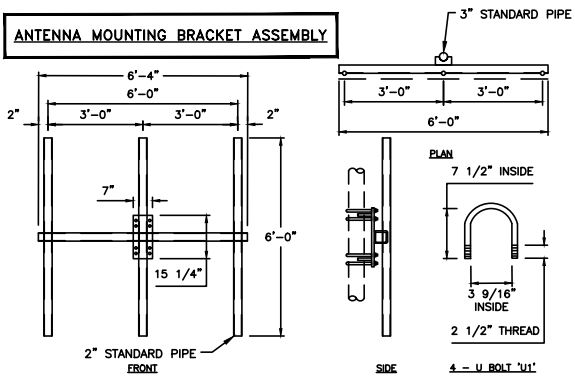

ANTENNA MOUNTING BRACKET ASSEMBLY 'B1' DETAIL

NO SCALE 1

RAYCAP RDIDC-9181-PF-48 DC SURGE PROTECTION (OVP)	
DIMENSIONS (HxWxD)	18.98"x14.39"x8.15"
WEIGHT	21.82 LBS

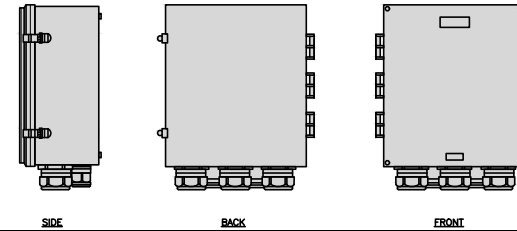
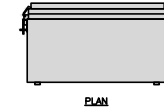

SURGE SUPPRESSION DETAIL (OVP)

NO SCALE 2

Fujitsu-DiSH Dual-Band RU Technical Specifications

RU General Specification	
Part number	TA08025-B604
TRX Configuration	4T4R
Operating Frequency	N70 & n66 Frequencies (Dual-Band)
Instantaneous Bandwidth	n70: DL:25MHz, UL:15MHz n66: DL:90MHz, UL:70MHz
Operation Bandwidth (3GPP)	n70: DL:25MHz, UL:15MHz n66: DL:90MHz, UL:70MHz
CC BW	5/10/20 MHz
Capacity	N70:2Cr(5/10/20 MHz) + N66:2Cr(5/10/20 MHz) N70:1Cr(5/10/20 MHz) + N66:3Cr(5/10/20 MHz)
Interface to DU	ORAN 7.2x / 10G optical IF
TX Specification	
Output Power per TX	n70: 20-40W per port n66: 40-60W per port Total 80W per port
ACLR	Compliant with 3GPP TS 38.104
Transmitter Spurious Emissions	Compliant with 3GPP TS 38.104
EVM	Compliant with 3GPP TS 38.104
RX Specification	
Noise Figure	2.5dB (normal condition 2.2dB)
Blocking Features	Compliant with 3GPP TS 38.104
Receiver spurious emissions	Compliant with 3GPP TS 38.104
Mechanical Specification	
Volume	30 L
Dimension	W:400mm, H: 380mm, D: 200mm
Antenna Connector Type	4.3-10 RF connector
Antenna Control Interface	AISG
Power Supply	DC -58 ~ -36V
Power Consumption	<1300W
Weight	29 kg
Environmental	
Humidity (Absolute humidity)	0.03 g/m3 ~ 30 g/m3
Atmospheric Pressure	Between 70 kPa and 106 kPa
Operating Temperature	-40°C ~ +55°C
IP Rating	IP65
Cooling	Passive
Mounting Options	
Pole	TBD
Wall	TBD

FUJITSU DUAL BAND RRU SPECS

NO SCALE 3

Fujitsu - DiSH Triple-band RU Technical Specifications

RU General Specification	
Part number	TA08025-B605
TRX Configuration	4T4R
Operating Frequency	n71 & n29 & n26 Frequencies (Triple-Band)
Instantaneous Bandwidth	n71: 35MHz n29: 11MHz n26: 7MHz
Operation Bandwidth (3GPP)	n71: 35MHz n29: 10MHz n26: 5MHz
CC BW	5/10/20 MHz
Capacity	n71:2Cr(5/10/20MHz)/NB-IOT n26:1Cr(5MHz)/NB-IOT n29:2Cr(5/10MHz)
Interface to DU	ORAN 7.2x / 10G optical IF
TX Specification	
Output Power per TX	n71: 30W per port n29: 40W per port n26: 10 W per port
ACLR	Compliant with 3GPP TS 38.104
Transmitter Spurious Emissions	Compliant with 3GPP TS 38.104
EVM	Compliant with 3GPP TS 38.104
RX Specification	
Noise Figure	2.5dB (normal condition 2.2dB)
Blocking Features	Compliant with 3GPP TS 38.104
Receiver spurious emissions	Compliant with 3GPP TS 38.104
Mechanical Specification	
Volume	35 L
Dimension	W:400mm, H: 380mm, D: 230mm
Antenna Connector Type	4.3-10 RF connector
Antenna Control Interface	AISG
Power Supply	DC -58 ~ -36V
Power Consumption	<1300W
Weight	34 kg
Environmental	
Humidity (Absolute humidity)	0.03 g/m3 ~ 30 g/m3
Atmospheric Pressure	Between 70 kPa and 106 kPa
Operating Temperature	-40°C ~ +55°C
IP Rating	IP65
Cooling	Passive

FUJITSU TRIPLE BAND RRU SPECS

NO SCALE 4



IT IS A VIOLATION OF LAW FOR ANY PERSON, UNLESS THEY ARE ACTING UNDER THE DIRECTION OF A LICENSED PROFESSIONAL ENGINEER, TO ALTER THIS DOCUMENT.

DRAWN BY:	CHECKED BY:	APPROVED BY:
BWG	AMR	AB

RFDS REV #: 2

ZONING DOCUMENTS

REV	DATE	DESCRIPTION
0	11/15/2021	FINAL ZONING DRAWINGS
1	12/03/2021	CLIENT COMMENTS
2	12/13/2021	CLIENT COMMENTS
3	03/09/2022	SCE COMMENTS
4	05/09/2022	SCE COMMENTS
5	05/31/2022	SCE COMMENTS
6	07/06/2022	SCE COMMENTS

A&E PROJECT NUMBER
LALAX04290B

DISH Wireless, L.L.C.
PROJECT INFORMATION
LALAX04290B
N/O ARROYO DR & E/O
ACKLEY ST
MONTEREY PARK, CA 91755

SHEET TITLE
EQUIPMENT SPECS

SHEET NUMBER

A-6



MX08FRO665-20
NWATM X-Pol 8-Port Antenna

X-Pol 8-Port 6 ft 65° Fast Roll Off:

4 ports 617-894 MHz and 4 ports 1695-2200 MHz

- Fast Roll Off (FROTM) azimuth beam pattern improves Intra- and Inter-cell SINR
- Excellent passive intermodulation (PIM) performance reduces harmful interference.
- Fully integrated (iRETs) with independent RET control for low and mid bands for ease of network optimization
- SON-Ready array spacing supports beamforming capabilities.
- High total power handling to maximize network efficiency
- Reduced tower loading for ease of site deployment

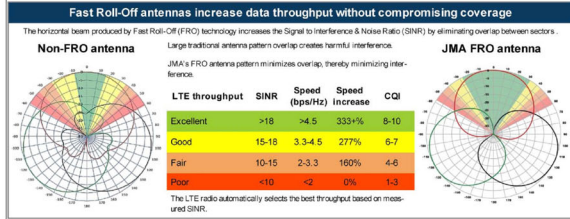

Electrical specification (minimum/maximum)	Ports 1, 2, 3, 4		Ports 5, 6, 7, 8		
Frequency bands, MHz	617-698	698-894	1695-1880	1850-1990	1920-2200
Polarization	± 45°		± 45°		
Gain over all tilts, max, dBi	13.6	14.8	18.5	18.3	18.8
Horizontal beamwidth (HBW), degrees ¹	68	62	62	62	64
Front-to-back ratio, co-polar power @180°, dB	>28	>29	>32	>31	>32
Vertical beamwidth (VBW), degrees ¹	14.2	12.5	5.4	5.2	4.9
Electrical downtilt (EDT) range, degrees	2-14		2-12		
First upper side lobe (USLS) suppression, dB ¹	≤-16.0	≤-16.5	≤-18.0	≤-18.0	≤-18.0
Minimum cross-polar isolation, port-to-port, dB ¹	25	25	25	25	25
Max VSWR / return loss, dB	1.5:1 / -14.0		1.5:1 / -14.0		
Max passive intermodulation (PIM), 2x20W carrier, dBc	-153		-153		
Max input power per any port, watts	300		250		
Total composite power all ports (1-8), watts ²			1500		

¹ Typical value over frequency and tilt

©2021 JMA Wireless. All rights reserved. This document contains proprietary information. All products, company names, brands, and logos are trademarks™ or registered® trademarks of their respective holders. All specifications are subject to change without notice. +1 315.431.7100 customerservice@jma.wireless.com

02/09/21 V3.0

Page 1



MX08FRO665-20
NWATM X-Pol 8-Port Antenna

² Power rated up to +55 °C

Electrical specification (minimum/maximum)	Ports 1, 2, 3, 4		Ports 5, 6, 7, 8		
Frequency bands, MHz	617-698	698-894	1695-1880	1850-1990	1920-2200
Average gain over all tilts, dBi (Gain Tolerance)	13.0±0.6	14.2±0.6	18.1±0.4	17.9±0.4	18.3±0.5
Horizontal beamwidth tolerance (HBW), degrees ¹	±5	±6.5	±5.0	±3.5	±3.5
Vertical beamwidth tolerance (VBW), degrees	±0.5	±0.5	±0.3	±0.3	±0.3
Front-to-back ratio, co-polar power @180°± 30°, dB	>27	>25	>25	>27	>26
X-Pol discrimination (CPR) at boresight, dB	>22	>20	20	>21	>22
First upper side lobe (USLS) suppression boresight to 20°, dB ¹	≤-16	≤-15	≤-16	≤-16	≤-16

Mechanical specifications	
Dimensions height/width/depth, inches (mm)	72.8/ 20.0/ 8.0 (1849/ 508.0/ 203.2)
Shipping dimensions length/width/height, inches (mm)	77.3/ 23.8/ 14.5 (1963.42/ 605/ 368)
No. of RF input ports, connector type, and location	8 x 4.3-10 female, bottom
RF connector torque	96 lbf-in (10.85 N-m or 8 lbf-ft)
Net antenna weight, lb (kg)	64.5 (29.3)
Shipping weight, lb (kg)	104 (47.2)
Antenna mounting and downtilt kit included with antenna	91900318
Net weight of the mounting and downtilt kit, lb (kg)	18 (8.2)
Range of mechanical up/down tilt	-2° to 12°
Rated wind survival speed, mph (km/h)	150 (241)
Frontal and lateral wind loading @ 150 km/h, lbf (N)	108.1 (480.9), 20.5 (91.2)
Effective projected area @ 150 km/h (EPA), frontal, sq ft	4.9

JMA ANTENNA MOUNT BRACKET #91900318	
TOTAL WEIGHT (WITH BRACKETS)	18 lbs (8.18 kg)
POLE DIAMETER RANGE	2.5" TO 4.5"

NOTE: KIT #91900318, TOP AND BOTTOM BRACKETS FOR 4-PORT AND 8-PORT ANTENNAS. ANTENNA BRACKET NOT PART OF KIT

NOTE: OR DISH Wireless, L.L.C. APPROVED EQUIVALENT

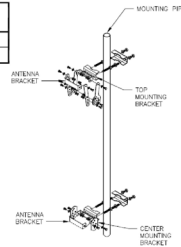

ANTENNA BRACKET DETAIL

©2021 JMA Wireless. All rights reserved. This document contains proprietary information. All products, company names, brands, and logos are trademarks™ or registered® trademarks of their respective holders. All specifications are subject to change without notice. +1 315.431.7100 customerservice@jma.wireless.com

02/09/21 V3.0

Page 2



5701 SOUTH SANTA FE DRIVE
LITTLETON, CO 80120



3659 GREEN ROAD, SUITE 214
CLEVELAND, OH 44122

IT IS A VIOLATION OF LAW FOR ANY PERSON, UNLESS THEY ARE ACTING UNDER THE DIRECTION OF A LICENSED PROFESSIONAL ENGINEER, TO ALTER THIS DOCUMENT.

DRAWN BY: CHECKED BY: APPROVED BY:

BWG AMR AB

RFDS REV #: 2

ZONING DOCUMENTS

SUBMITTALS		
REV	DATE	DESCRIPTION
0	11/15/2021	FINAL ZONING DRAWINGS
1	12/03/2021	CLIENT COMMENTS
2	12/13/2021	CLIENT COMMENTS
3	03/09/2022	SCE COMMENTS
4	05/09/2022	SCE COMMENTS
5	05/31/2022	SCE COMMENTS
6	07/06/2022	SCE COMMENTS

A&E PROJECT NUMBER
LALAX04290B

DISH Wireless, L.L.C.
PROJECT INFORMATION
LALAX04290B
N/O ARROYO DR & E/O
ACKLEY ST
MONTEREY PARK, CA 91755

SHEET TITLE
ANTENNA SPEC SHEETS

SHEET NUMBER

S-1



MX08FRO665-20
NWAV™ X-Pol 8-Port Antenna

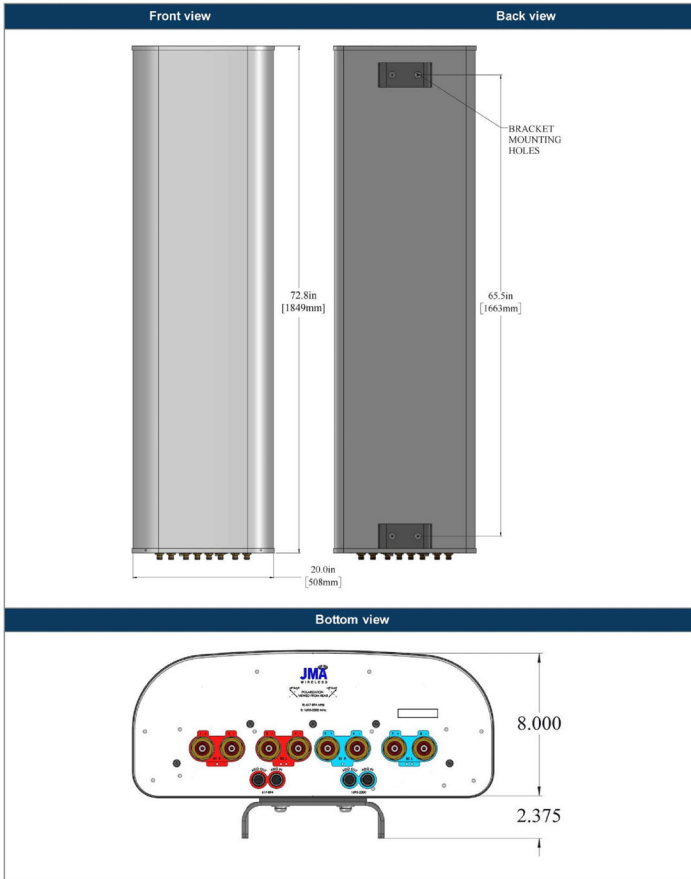

©2021 JMA Wireless. All rights reserved. This document contains proprietary information. All products, company names, brands, and logos are trademarks™ or registered® trademarks of their respective holders. All specifications are subject to change without notice. +1 315.431.7100 customerservice@jmawireless.com

02/09/21 V3.0
 Page 3



MX08FRO665-20
NWAV™ X-Pol 8-Port Antenna

Remote electrical tilt (RET 2000) information

RET location	Integrated into antenna
RET interface connector type	8-pin AISG connector per IEC 60130-9
RET connector torque	Min 0.5 N·m to max 1.0 N·m (hand pressure & finger tight)
RET interface connector quantity	2 pairs of AISG male/female connectors
RET interface connector location	Bottom of the antenna
Total no. of internal RETs 617-894 MHz	1
Total no. of internal RETs 1695-2200 MHz	1
RET input operating voltage, vdc	10-30
RET max power consumption, idle state, W	≤ 2.0
RET max power consumption, normal operating conditions, W	≤ 10.0
RET communication protocol	Hardware AISG 3.0; firmware AISG 2.0, field-upgradable to AISG 3.0

RET and RF connector topology

Each RET device can be controlled via the designated external AISG connector as shown below:

Band	RF port	Band	RF port
617-894	1-4	1695-2200	5-8

Array topology

4 sets of radiating arrays

Band	RF port
617-894	1-2
617-894	3-4
1695-2200	5-6
1695-2200	7-8

R1: 617-894 MHz
 R2: 617-894 MHz
 B1: 1695-2200 MHz
 B2: 1695-2200 MHz

1695 – 2200 (B1)
 617-894 (R1)
 1695 – 2200 (B2)
 617-894 (R2)

©2021 JMA Wireless. All rights reserved. This document contains proprietary information. All products, company names, brands, and logos are trademarks™ or registered® trademarks of their respective holders. All specifications are subject to change without notice. +1 315.431.7100 customerservice@jmawireless.com

02/09/21 V3.0
 Page 4



5701 SOUTH SANTA FE DRIVE
 LITTLETON, CO 80120



3659 GREEN ROAD, SUITE 214
 CLEVELAND, OH 44122

IT IS A VIOLATION OF LAW FOR ANY PERSON, UNLESS THEY ARE ACTING UNDER THE DIRECTION OF A LICENSED PROFESSIONAL ENGINEER, TO ALTER THIS DOCUMENT.

DRAWN BY:	CHECKED BY:	APPROVED BY:
BWG	AMR	AB
RFDS REV #:		2

ZONING DOCUMENTS

SUBMITTALS		
REV	DATE	DESCRIPTION
0	11/15/2021	FINAL ZONING DRAWINGS
1	12/03/2021	CLIENT COMMENTS
2	12/13/2021	CLIENT COMMENTS
3	03/09/2022	SCE COMMENTS
4	05/09/2022	SCE COMMENTS
5	05/31/2022	SCE COMMENTS
6	07/06/2022	SCE COMMENTS

A&E PROJECT NUMBER
LALAX04290B

DISH Wireless, L.L.C.
 PROJECT INFORMATION
LALAX04290B
 N/O ARROYO DR & E/O
 ACKLEY ST
 MONTEREY PARK, CA 91755

SHEET TITLE
ANTENNA SPEC SHEETS

SHEET NUMBER

S-2

Attachment 3

Photo Simulations



LALAX04290B
N/O ARROYO DR & E/O ACKLEY ST.
MONTEREY PARK, CA 91755



View 1 of 3: EAST LOOKING WEST

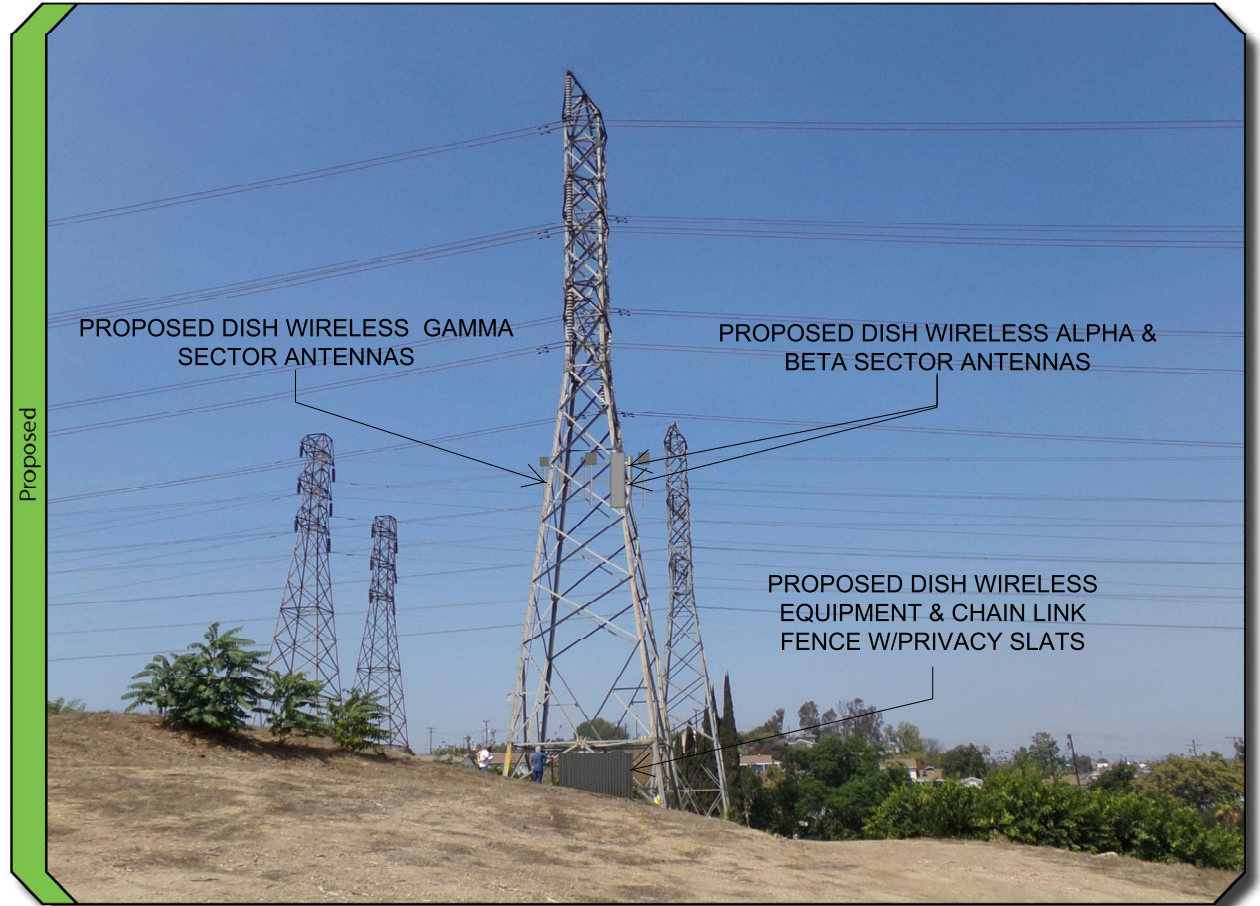

APRIL 18, 2022

Prepared by: TLM



LALAX04290B

N/O ARROYO DR & E/O ACKLEY ST.
MONTEREY PARK, CA 91755



View 2 of 3: SOUTH LOOKING NORTH

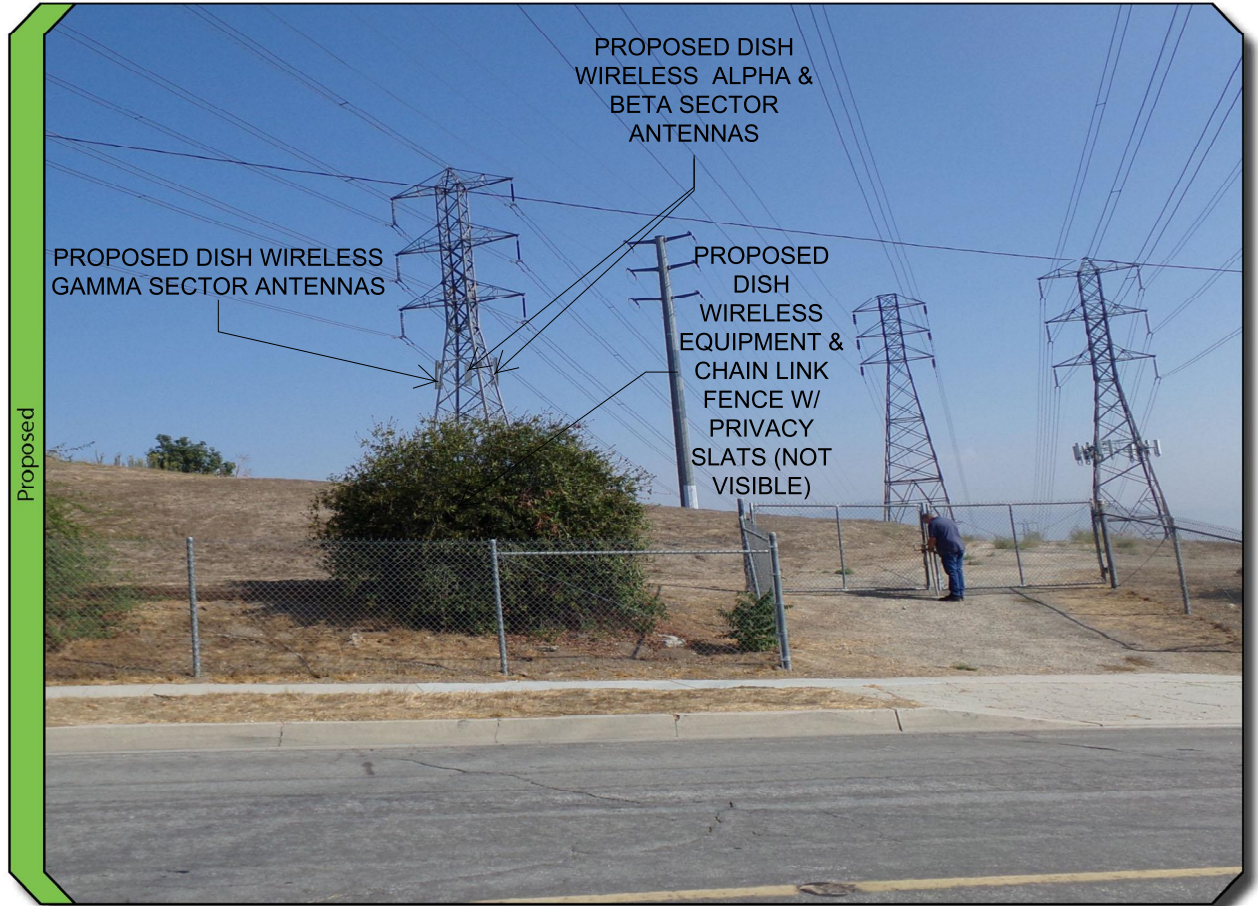
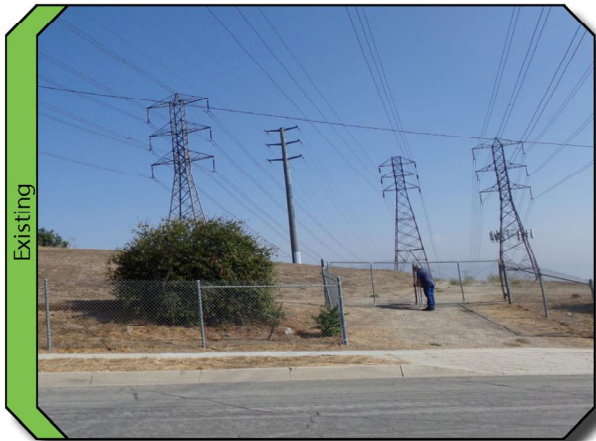
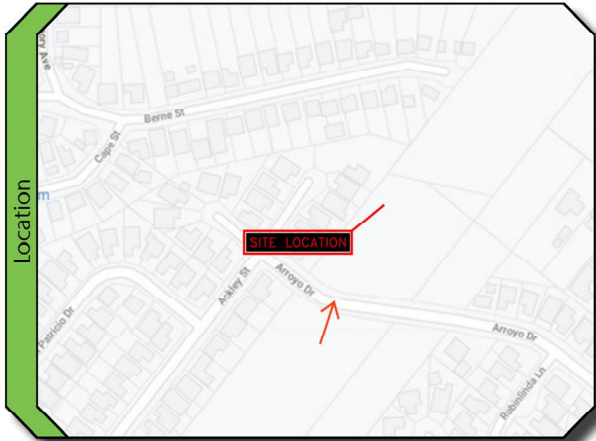

APRIL 18, 2022

Prepared by: TLM



LALAX04290B
N/O ARROYO DR & E/O ACKLEY ST.
MONTEREY PARK, CA 91755



View 3 of 3: WEST LOOKING EAST



APRIL 18, 2022

Prepared by: TLM



City Council Staff Report

DATE: November 16, 2022

AGENDA ITEM NO: New Business - 5A

TO: The Honorable Mayor and City Council

FROM: Steve Sizemore, Interim Community Development Director
Jessica Serrano, Planning Manager

SUBJECT: Introducing and waiving the first reading of an ordinance extending the effective date for the 2020 Monterey Park Business Recovery Program from December 30, 2022 to May 31, 2023.

RECOMMENDATION:

It is recommended that the City Council consider:

1. Introducing and waiving the first reading of an ordinance extending the effective date for the 2020 Monterey Park Business Recovery Program from December 30, 2022 to May 31, 2023.
2. Taking such additional, related, action that may be desirable.

EXECUTIVE SUMMARY:

In 2020, at the onset of the COVID-19 pandemic, the City adopted a series of ordinances aimed at combating the effects of the pandemic on our local economy including the creation of the 2020 Monterey Park Business Recovery Program (the "Program"). The Program included temporary regulations to help local businesses recover from the devastating effects of the pandemic. The majority of the temporary regulations have been codified permanently into the Monterey Park Municipal Code, except for the outdoor temporary event permit regulations. The outdoor temporary event permit regulations were first adopted in July 15, 2020 and have since been extended twice. They are set to expire on December 30, 2022.

Staff prepared an ordinance to adopt *permanent* regulations for this valuable outdoor dining use. On November 8, 2022, the Planning Commission conducted a duly noticed public hearing and adopted a resolution recommending City Council approval of a draft ordinance with permanent regulations.

To ensure ample time for noticing and presentation to the City Council for its consideration of the ordinance with permanent regulations, staff recommends the City Council adopt the attached proposed extension ordinance to continue the effective date of the Program from December 30, 2022 to May 31, 2023. This would allow the temporary outdoor dining regulations to continue for a specified period.

FISCAL IMPACT:

There are no direct foreseeable direct costs with extending the Program. It is anticipated that the program will assist local businesses. This will also help stabilize the City's revenue projections for budgeting purposes.

Respectfully submitted by:

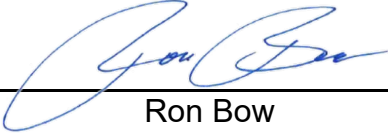

Ron Bow
City Manager

Prepared by:

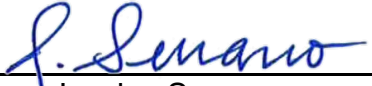

Jessica Serrano
Planning Manager

Reviewed by:



Joaquin Vazquez
Deputy City Attorney

ATTACHMENTS:

1. Proposed Ordinance extending the time of the 2020 Monterey Park Business Recovery Program from December 30, 2022 to May 31, 2023.
2. Ordinance No. 2207 amending the 2020 Monterey Park Business Recovery Program and extending its effective date to December 30, 2022.

ATTACHMENT 1
Proposed Ordinance

ORDINANCE NO. _____

AN ORDINANCE EXTENDING THE 2020 MONTEREY PARK BUSINESS RECOVERY PROGRAM'S EFFECTIVE DATE TO MAY 31, 2023.

The City Council does ordain as follows:

SECTION 1. *Findings.* The City Council finds, determines and declares as follows:

- A. Since March 11, 2020, the City (and the nation) has been in a declared a state of local emergency due to the COVID-19 Pandemic (the "Emergency").
- B. During the Emergency, the City Council adopted a series of regulations (Ordinance Nos. 2178, 2182, 2184, and 2185) which are, collectively, the 2020 Monterey Park Business Recovery Program (the "Program").
- C. Since the Program was adopted, the City Council took various actions to codify various regulations on a permanent basis. Most of the Program is now codified within the Monterey Park Municipal Code ("MPMC").
- D. The remaining temporary regulations that affect outdoor dining and events within the Program will expire December 30, 2022.
- E. A report was provided to the City Council regarding the ongoing efforts to stimulate the local economy through the Program's outdoor dining and events regulations and future consideration of making certain associated regulations permanent. Based upon that report, the City Council finds it is in the public interest to extend the outdoor dining and events permit regulations through May 31, 2023. This will give staff additional time to recommend appropriate changes to the Monterey Park Municipal Code ("MPMC") that will help promote the City Council's intent to assist local businesses recover from the Emergency.

SECTION 2. *Environmental Assessment.* This Ordinance was reviewed pursuant to the California Environmental Quality Act (Public Resources Code §§ 21000, *et seq.*, "CEQA") and the regulations promulgated thereunder (14 Cal. Code of Regulations §§15000, *et seq.*, the "CEQA Guidelines"). Adopting this Ordinance is exempt from further environmental review because it establishes rules and procedures for operation of existing facilities; minor temporary use of land; minor alterations in land use; new construction of small structures; and minor structures accessory to existing commercial facilities. The Ordinance, therefore, is categorically exempt from further CEQA review under CEQA Guidelines §§ 15301; 15303, 15304(e); 15305; and 15311. Further, the adopting the ordinance is also exempt from review under CEQA pursuant to CEQA Guidelines § 15061(b)(3) because the ordinance is for general policies and procedure-making. It can be seen with certainty that there is no possibility that the Ordinance may have a significant effect on the environment. Individual projects utilizing the 2020

Monterey Park Business Recovery Program will each be separately subject to an environmental assessment. Finally, this Ordinance is exempt from further review pursuant to CEQA Guidelines § 15269(a) because the protection of public and private property is necessary to maintain service essential to the public, health and welfare.¹

SECTION 3. *Extension of Time.* The portions of the Program, as extended under Section 3 of Ordinance No. 2207 (adopted April 21, 2021), are further extended through May 31, 2023. This Ordinance (and, therefore, the Program) will automatically be repealed and will become ineffective on June 1, 2023, unless the City Council takes additional action to extend the effectiveness of this Ordinance or supersedes it via a subsequently adopted Ordinance.

SECTION 4. *Amendments.* The portions of the Program codified within the MPMC take supersede all portions of the Program that are uncodified. Accordingly, any conflict between the MPMC and the remaining portions of the Program will be resolved in favor of the MPMC.

SECTION 5. *Construction.* This Ordinance must be broadly construed to achieve the purposes stated in this Ordinance. It is the City Council's intent that the provisions of this Ordinance be interpreted or implemented by the City and others in a manner that facilitates the purposes set forth in this Ordinance.

SECTION 6. *Enforceability.* Amendment or repeal of any provision of any previously adopted Ordinance does not affect any penalty, forfeiture, or liability incurred before, or preclude prosecution and imposition of penalties for any violation occurring before this Ordinance's effective date. Any such repealed part will remain in full force and effect for sustaining action or prosecuting violations occurring before the effective date of this Ordinance.

SECTION 7. *Validity of Previous Code Sections.* If this entire Ordinance or its application is deemed invalid by a court of competent jurisdiction, any repeal or amendment of any other ordinance by this Ordinance will be rendered void and cause such previous ordinance to remain in full force and effect for all purposes.

SECTION 8. *Reliance on Record.* Every one of the findings and determinations in this Ordinance are based on the competent and substantial evidence, both oral and written, contained in the entire record relating to the project. The findings and determinations constitute the independent findings and determinations of the City Council in all respects and are fully and completely supported by substantial evidence in the record as a whole.

SECTION 9. *Severability.* If any part of this Ordinance or its application is deemed invalid by a court of competent jurisdiction, the City Council intends that such invalidity will not affect the effectiveness of the remaining provisions or applications and, to this

¹ CEQA findings regarding an anticipated imminent emergency are valid (see *CalBeach Advocates v. City of Solana Beach* (2002) 103 Cal.App.4th 529).

end, the provisions of this Ordinance are severable.

SECTION 10. *Recording.* The City Clerk, or her duly appointed deputy, is directed to certify the passage and adoption of this Ordinance; cause it to be entered into the City of Monterey Park's book of original ordinances; make a note of the passage and adoption in the records of this meeting; and, within 15 days after the passage and adoption of this Ordinance, cause it to be published or posted in accordance with California law.

SECTION 11. *Electronic Signatures.* Pursuant to MPMC Chapter 3.95, this Ordinance may be executed with electronic signatures in accordance with Government Code §16.5. Such electronic signatures will be treated in all respects as having the same effect as an original signature.

SECTION 12. *Effective Date.* This Ordinance will become effective 30 days after its adoption and remain effective unless superseded or repealed.

PASSED AND ADOPTED this ____ day of _____, 2022.

Henry Lo, Mayor

ATTEST:

Vincent D. Chang, City Clerk

APPROVED AS TO FORM:
KARL H. BERGER, CITY ATTORNEY



Joaquin Vazquez, City Attorney

ATTACHMENT 2
Ordinance No. 2207

ORDINANCE NO. 2207

AN ORDINANCE AMENDING THE 2020 MONTEREY PARK BUSINESS RECOVERY PROGRAM AND EXTENDING ITS EFFECTIVE DATE TO DECEMBER 30, 2022.

The City Council does ordain as follows:

SECTION 1. *Findings.* The City Council finds, determines and declares as follows:

- A. Since March 11, 2020, the City (and the nation) has been in a declared a state of local emergency due to the COVID-19 Pandemic (the “Emergency”).
- B. During the Emergency, the City Council adopted a series of regulations (Ordinance Nos. 2178, 2182, 2184, and 2185) which are, collectively, the 2020 Monterey Park Business Recovery Program (the “Program”).
- C. Since the Program was adopted, the City Council took various actions to codify various regulations on a permanent basis. Most of the Program is now codified within the Monterey Park Municipal Code (“MPMC”). The remaining temporary regulations that affect outdoor dining and events within the Program will expire June 30, 2021.
- D. The City Manager and Economic Development Manager provided a report to the City Council regarding the ongoing efforts to stimulate the local economy by using the Program’s regulations. Based upon that report, the City Council finds it is in the public interest to extend the outdoor dining and events permit regulations to 2022. This will give the City Manager additional time to recommend appropriate changes to the Monterey Park Municipal Code (“MPMC”) that will help promote the City Council’s intent to assist local businesses recover from the Emergency.

SECTION 2. *Environmental Assessment.* This Ordinance was reviewed pursuant to the California Environmental Quality Act (Public Resources Code §§ 21000, *et seq.*, “CEQA”) and the regulations promulgated thereunder (14 Cal. Code of Regulations §§15000, *et seq.*, the “CEQA Guidelines”). Adopting this Ordinance is exempt from further environmental review because it establishes rules and procedures for operation of existing facilities; minor temporary use of land; minor alterations in land use; new construction of small structures; and minor structures accessory to existing commercial facilities. The Ordinance, therefore, is categorically exempt from further CEQA review under CEQA Guidelines §§ 15301; 15303, 15304(e); 15305; and 15311. Further, the adopting the ordinance is also exempt from review under CEQA pursuant to CEQA Guidelines § 15061(b)(3) because the ordinance is for general policies and procedure-making. It can be seen with certainty that there is no possibility that the Ordinance may have a significant effect on the environment. Individual projects utilizing the 2020 Monterey Park Business Recovery Program will each be separately subject to an

environmental assessment. Finally, this Ordinance is exempt from further review pursuant to CEQA Guidelines § 15269(a) because the protection of public and private property is necessary to maintain service essential to the public, health and welfare.¹

SECTION 3. *Extension of Time.* The Sunset Clause set forth in Section 3 of Ordinance No. 2197 (adopted November 4, 2020) is further extended until December 30, 2022. To ensure that the City Manager reviews the MPMC as contemplated by the 2020 Monterey Park Business Recovery Program, this Ordinance (and, therefore, the Program) will automatically be repealed and will become ineffective on December 31, 2022, unless the City Council takes additional action to extend the effectiveness of this Ordinance or supersedes it via a subsequently adopted Ordinance.

SECTION 4. *Amendments.* The portions of the Program codified within the MPMC take supersede all portions of the Program that are uncodified. Accordingly, any conflict between the MPMC and the remaining portions of the Program will be resolved in favor of the MPMC.

SECTION 5. *Construction.* This Ordinance must be broadly construed to achieve the purposes stated in this Ordinance. It is the City Council's intent that the provisions of this Ordinance be interpreted or implemented by the City and others in a manner that facilitates the purposes set forth in this Ordinance.

SECTION 6. *Enforceability.* Amendment or repeal of any provision of any previously adopted Ordinance does not affect any penalty, forfeiture, or liability incurred before, or preclude prosecution and imposition of penalties for any violation occurring before this Ordinance's effective date. Any such repealed part will remain in full force and effect for sustaining action or prosecuting violations occurring before the effective date of this Ordinance.

SECTION 7. *Validity of Previous Code Sections.* If this entire Ordinance or its application is deemed invalid by a court of competent jurisdiction, any repeal or amendment of any other ordinance by this Ordinance will be rendered void and cause such previous ordinance to remain in full force and effect for all purposes.

SECTION 8. *Reliance on Record.* Every one of the findings and determinations in this Ordinance are based on the competent and substantial evidence, both oral and written, contained in the entire record relating to the project. The findings and determinations constitute the independent findings and determinations of the City Council in all respects and are fully and completely supported by substantial evidence in the record as a whole.

SECTION 9. *Severability.* If any part of this Ordinance or its application is deemed

¹ CEQA findings regarding an anticipated imminent emergency are valid (see *CalBeach Advocates v. City of Solana Beach* (2002) 103 Cal.App.4th 529).

invalid by a court of competent jurisdiction, the City Council intends that such invalidity will not affect the effectiveness of the remaining provisions or applications and, to this end, the provisions of this Ordinance are severable.

SECTION 10. *Recording.* The City Clerk, or her duly appointed deputy, is directed to certify the passage and adoption of this Ordinance; cause it to be entered into the City of Monterey Park's book of original ordinances; make a note of the passage and adoption in the records of this meeting; and, within 15 days after the passage and adoption of this Ordinance, cause it to be published or posted in accordance with California law.

SECTION 11. *Electronic Signatures.* Pursuant to MPMC Chapter 3.95, this Ordinance may be executed with electronic signatures in accordance with Government Code §16.5. Such electronic signatures will be treated in all respects as having the same effect as an original signature.

SECTION 12. *Effective Date.* This Ordinance will become effective 30 days after its adoption and remain effective unless superseded or repealed.

PASSED AND ADOPTED this 5th day of May, 2021.

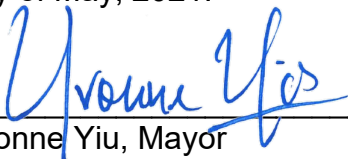

Yvonne Yiu, Mayor

ATTEST:



Vincent D. Chang, City Clerk

APPROVED AS TO FORM:

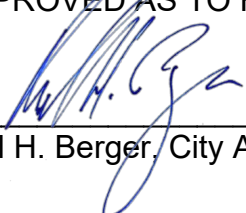

Karl H. Berger, City Attorney

STATE OF CALIFORNIA)
COUNTY OF LOS ANGELES) §
CITY OF MONTEREY PARK)

I, Vincent D. Chang, City Clerk of the City of Monterey Park, California, do hereby certify that the foregoing Ordinance No. 2207 was introduced, and placed upon its first reading at a regular meeting of the City Council of the City of Monterey Park, held on the 21st day of April, 2021. That thereafter on the 5th day of May, 2021, said Ordinance was duly passed, approved and adopted by the following vote:

Ayes: Council Members: Chan, Liang, Sornoso, Lo, Yiu
Noes: Council Members: None
Absent: Council Members: None
Abstain: Council Members: None

Dated this 5th day of May, 2021.

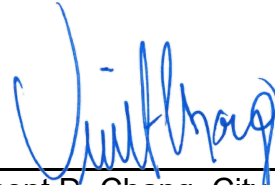

Vincent D. Chang, City Clerk
City of Monterey Park, California

RESOLUTION NO.

**A RESOLUTION OF THE CITY COUNCIL OF THE CITY OF
MONTEREY PARK RECOGNIZING NOVEMBER 13 – 19, 2022,
AS LA VS. HATE UNITED AGAINST HATE WEEK**

BE IT RESOLVED by the Council of the City of Monterey Park as follows:

SECTION 1. The City Council finds as follows:

- A. The United States is a nation of immigrants whose strength comes from its diversity.
- B. The Constitution enshrines equality for all individuals, regardless of race, gender, orientation, religion, or political views.
- C. There is an ongoing escalation of hate speech that encourages the propagation of racist, xenophobic, anti-Semitic, sexist, homophobic, Islamophobic, and other bigoted views by emboldened hate groups and individuals.
- D. Deep divisions within our country result from extreme ideology, further strengthening a cycle of mistrust and suspicion fueled by fear, anxiety, and insecurity. The number of hate crimes across the United States has increased dramatically over the past six years.
- E. The City of Monterey Park is dedicated to preventing and opposing hate and intolerance in our communities. The City Council endorses a resolution in support of LA vs. Hate *United Against Hate Week 2022* and city activities to stop hate, intolerance and bullying and promote safe, inclusive, and equitable neighborhoods.
- F. Education, compassion, and cooperation are crucial to unlocking understanding and embracing differences between people.
- G. We seek to join other communities in California and cities across this county in this third annual LA vs. Hate *United Against Hate Week* as an essential step in bridging divisions and strengthening our communities.
- H. The City Council for the City of Monterey Park hereby declares its enthusiastic support of LA vs. Hate *United Against Hate Week* activities in our county November 13 – 19, 2022, and each day beyond.

SECTION 2: *Electronic Signatures.* This Resolution may be executed with electronic signatures in accordance with Government Code §16.5. Such electronic signatures will be treated in all respects as having the same effect as an original signature.

SECTION 3: Recordation. The Mayor, or presiding officer, is authorized to sign this Resolution signifying its adoption by the City Council of the City of Monterey Park, and the City Clerk, or her duly appointed deputy, may attest thereto.

SECTION 4: Effective Date. This Resolution will become effective immediately upon adoption and will remain effective unless repealed or superseded.

(Mayor signature and attestation must be on the same page.)

PASSED AND ADOPTED this ____ day of _____, 2022.

Henry Lo, Mayor

Attest:

Vincent Chang, City Clerk

ATTEST:

Vincent D. Chang, City Clerk

State of California)
County of Los Angeles) ss.
City of Monterey Park)

I, Vincent D. Chang, City Clerk of the City of Monterey Park, California, do hereby certify that the foregoing Resolution No. ____ was duly and regularly adopted by the City Council of the City of Monterey Park at a meeting held on the __ day of November 2022, by the following vote:

Ayes:	Council Members:
Noes:	Council Members:
Absent:	Council Members:
Abstain:	Council Members:

Dated this day of November 2022.

Vincent D. Chang, City Clerk
Monterey Park, California